

## Kinematic Diagnosis System and environment

### BMW KDS (Beissbarth)



#### Table of contents

1. Foreword
  - 1.1 Objectives
  - 1.2 Further development of the BMW Kinematic Diagnosis System
  - 1.3 Technical data
  - 1.4 Scope of delivery
  - 1.5 Accessories required
  - 1.6 Accessories recommended
2. **Measuring options using the BMW Kinematic Diagnosis System**
  - 2.1 Front axle
  - 2.2 Rear axle
  - 2.3 Other measuring options
3. **System description**
  - 3.1 BMW Kinematic Diagnosis System 1, based on the Beissbarth ML4000
  - 3.2 Computer
  - 3.3 Graphical tablet
  - 3.4 Equipment cabinet
  - 3.5 Remote display
  - 3.6 Measuring sensors with CCD camera
  - 3.7 BMW Quick-acting clamp

3.8 Rotating / sliding plates

3.9 Sensor pins

3.10 Spoiler adapter

3.11 Quick-clamping units

3.12 Retainers

#### **4. Workstation**

4.1 Environment

4.2 Preconditions for alignment

4.3 Measuring tolerance

4.4 Levelling the measuring station

#### **5. Chassis-related terms**

5.1 Toe-differential angle

5.2 Camber

5.3 Toe-in

5.4 Castor

5.5 Geometrical drive axis / symmetrical axis

5.6 Wheel displacement angle

5.7 Kingpin offset

#### **6. Wheel suspension**

6.1 Rigid axle suspension

6.2 Independent wheel suspension

#### **7. Wheel alignment / procedure**

7.1 Measuring options

7.2 Preparatory work

7.3 Initial / final measurement

7.4 Printing out the data

#### **8. Special features**

8.1 Free wheel alignment

8.2 System settings

#### **9. BMW Kinematic Diagnosis System comparison (Bosch - Beissbarth)**

#### **10. Control modification (menu)**

10.1 Remote control with display

10.2 Brief operating instructions

10.3 Display support

#### **11. Updating the software / setpoint data**

11.1 Requirements

11.2 Procedure (Beissbarth)

11.3 Procedure (Bosch)

#### **12. Creating, copying and editing setpoint data**

12.1 Copying

12.2 Creating

12.3 Editing

#### **13. Special functions**

13.1 Customer-specific printer report header

13.2 Adjusting options

13.3 Rotating plate test

13.4 Viewing and deleting customer entries from database

## **14. Modifications within program**

## **15. Faults**

15.1 Tyre faults

15.2 Front axle faults

15.3 Rear axle faults

## **1. Foreword**

### **1.1 Objectives**

Wheel alignment has become an increasingly complex subject. The aim of this BMW Service Technology bulletin, therefore, is to achieve several objectives:

- Creation of guidelines for working with the BMW Kinematic Diagnosis System (KDS).
- Familiarisation with wheel alignment technology for current vehicles and clarifying any questions which arise in this connection.
- Transparency and clarification of different terms.
- Clarification of the causes of errors in the past, such that they can be avoided after reading this document.
- Creation of conditions for dealing safely with the BMW KDS.

### **1.2 Further development of the BMW Kinematic Diagnosis System**

- The BMW Kinematic Diagnosis System is an integrated part of automotive system concepts. It ensures that work is carried out in a particularly rational manner which is appropriate for BMW requirements, such that you can also be certain of being prepared for future technological developments. As far as precision and performance in wheel alignment and tuning is concerned, BMW, together with leading manufacturers, has made the best of what is technically feasible: the BMW Kinematic Diagnosis System.
- The BMW Kinematic Diagnosis System manufactured by Beissbarth is more than just the further development of conventional wheel alignment equipment. It sets new standards in precision, performance, speed and handling. It is a guarantor for the perfection which BMW service customers rely on.
- Ride comfort, road safety and tyre wear depend to a large extent on the perfect interplay of the vehicle's kinematic functions. BMW is constantly launching new generations of chassis which are even better than their predecessors. This is why there are fewer kinematics system adjusting points and narrower tolerances when measuring and tuning the chassis.
- With the use of the multi-link rear suspension and the E36, the electronic wheel alignment devices are no longer suitable for BMW wheel alignment purposes. This applies to both the measuring procedure and measuring precision. The generation of equipment which was approved with the E36 series still fulfils all the requirements placed on a modern wheel alignment device, including the use of the latest computer technology.
- Only BMW Kinematic Diagnosis Systems manufactured by Beissbarth and Bosch may be used for wheel alignment.

### **1.3 Technical Data**



- |                             |   |  |
|-----------------------------|---|--|
| 1. Display                  | - | 17" graphic screen with high-resolution graphics (640x480 pixels with 256 colours)   |
| 2. On-screen text           | - | in the appropriate national language   |
| 3. Wheel dimensions         | - | 12"...20"  |
| 4. Vehicle memory locations | - | unlimited  |
| 5. Rotating plates          | - | Loadbearing capacity 1000 kg, angle of rotation $\pm 360^\circ$ , 450 x 450 x 50 mm (L x W x H), sliding range $\pm 50$ mm, weight 18 kg |
| 6. Sliding plates           | - | Loadbearing capacity 1000 kg, angle of rotation $\pm 10^\circ$ , 450 x 450 x 50mm (L x W x H), sliding range $\pm 65$ mm, weight 17 kg   |
| 7. Electrical connection    | - | 100...115 V / 220...240 V 50/60 Hz, 0.5 kW (other connections on request)  |

#### 1.4 Scope of delivery

- 1 PC display device with graphic screen, graphical tablet, small or large equipment cabinet including automatic charging station, DIN A4 dot matrix printer
- 4 Measuring sensors with CCD camera technology and infrared data transmission with built-in power supply
- 1 Cable set (comprising 4 cables)
- 1 Brake clamping device
- 1 Steering lock device
- 2 Electronic precision rotating plates with integrated sensor without access ramps
- 2 Sliding plates without access ramps
- 4 BMW quick-clamping units, comprising a P8-68 locating bell and P267 01 quick-acting clamp including coated holding claws
- 1 Operating instructions for BMW KDS (8 languages)
- 1 BMW software and the BMW vehicle setpoint data with setting screens as well as text for the measurement preparations

### 1.5 Accessories required

- 2 Locating rods for positioning the vehicle
- 1 Set of sand bags for the prescribed loading

### 1.6 Accessories recommended

- 4 Quick-clamping units
- 2 Sets of access ramps
- 1 Remote control / display
- 1 Trolley (for ballast bags, rotating and sliding plates and 4 quick-acting clamps)

## 2. Measuring options using the BMW Kinematic Diagnosis System

### 2.1 Front axle

- Toe-in (single and total toe-in in relation to the geometrical drive axis)
- Camber (with steering wheel pointing straight ahead)
- Wheel displacement (in relation to the left-hand front wheel)
- Castor, kingpin inclination and toe-differential angle

### 2.2 Rear axle

- Toe-in (single and total toe-in in relation to the longitudinal centre plane of the vehicle --> previously called symmetrical axis)
- Geometrical drive axis
- Camber

### 2.3 Other measuring options

- Rear wheel displacement
- Wheelbase difference
- Lateral displacement on right
- Lateral displacement on left
- Track difference
- Axial displacement

## 3. System description

### 3.1 BMW Kinematic Diagnosis System 1, based on the Beissbarth ML4000

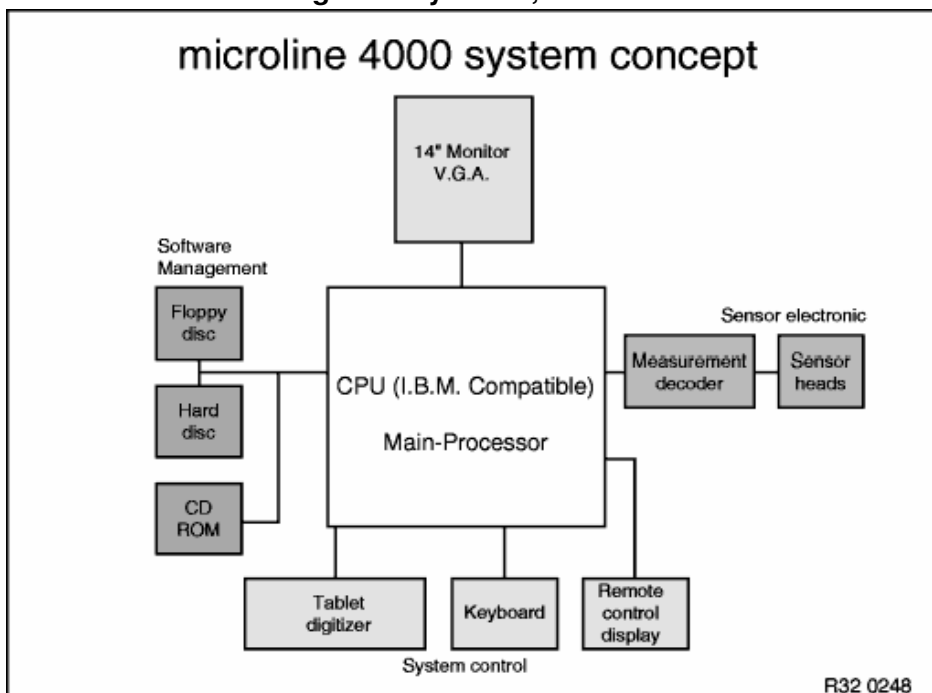

The KDS 1 is available in two different designs at no extra charge:

## 1. Mobile workstation



## 2. Mobile compact cabinet



The larger workstation offers a small storage area for accessories, whilst the compact cabinet is mobile and ideal for restricted working areas. Both variants can be supplied as a cableless measuring system (infrared). From the point of view of measuring technology, there is only a difference in the handling and equipping of the system. For both designs, the four measuring sensors are stored in integrated inserts with rechargeable battery charging points. When automatically charged over night, the measuring sensor batteries provide enough power for 10 hours of continuous use.

## 3.2 Computer



- The KDS 1 system comprises tested and reliable industrial components. The computer is an IBM-compatible, 32-bit Intel processor with CD ROM drive to the industry standard.

## 3.3 Graphical tablet

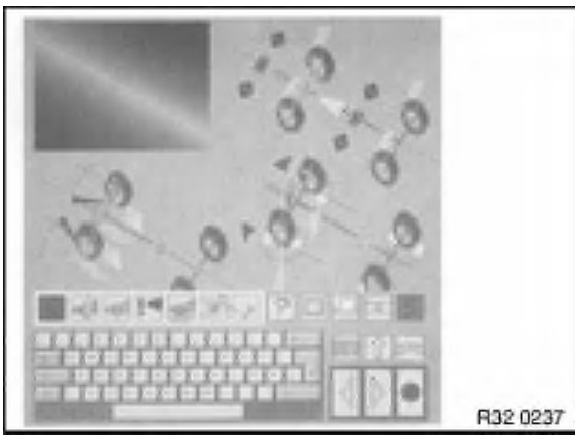

- All functions are shown in graphical form on a "pictogram" panel. The panel is protected by a plexiglass cover. It can easily be replaced if more extensive design modifications are necessary. The operator interface has no membrane and is thus protected against damage. The main functions are activated by clicking the icon with the digital pen.

### 3.4 Equipment cabinet

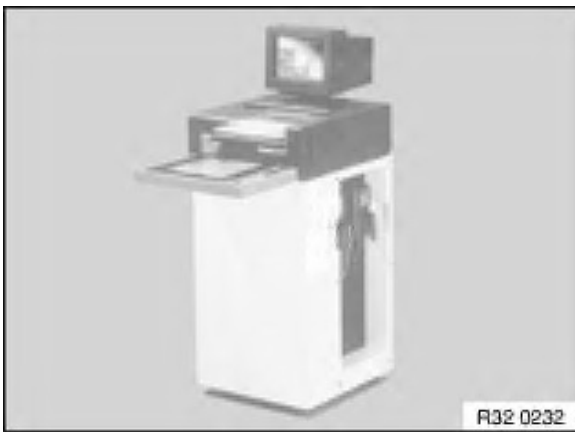

- The PC with graphic monitor and removable operating panel, supports for the measuring sensors, the remote control and the A4 printer are integrated into the workstation. The charging station is located in the cabinet and can also be connected to the measuring sensors and the remote control using the plug-in cables (operating while simultaneously charging the batteries).

### 3.5 Remote display



A cableless remote display can be supplied on request. The remote control keys are only active during measuring and adjustment (not for customer data input, or if selecting a vehicle or editing the setpoint data etc.). The following displays are supported by the remote control:

- Measured value with setpoint / actual comparison and tolerance bar
- Steering graphics for steering routines
- Live overview of the track / camber values with a setpoint / actual comparison
- Rim run-out compensation

### 3.6 Measuring sensors with CCD camera



The measuring sensors are each equipped for automatic measurement with two CCD cameras and their own processor for the cableless infrared transmission of data with integrated batteries.

Benefits:

- No temperature deviation
- Very high measuring resolution (the track could theoretically be measured in angular seconds)
- Single track range of more than  $\pm 9$  degrees for the constant display of toe-in when changing the tie-rod ends
- Exact system accuracy, i.e. when carrying out measurements at the vehicle following rim run-out compensation, the toe-in and camber measurements are accurate to 2 angular minutes

### 3.7 BMW Quick-acting clamp

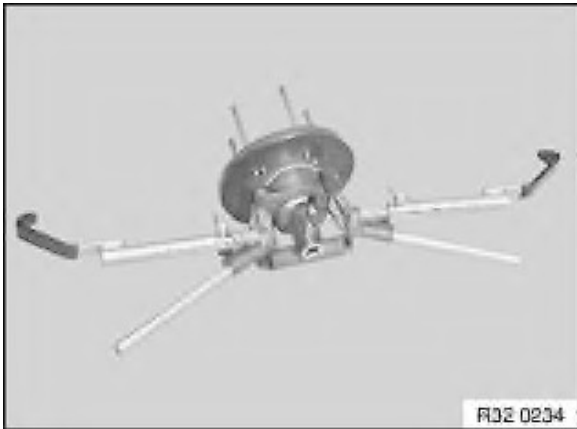

- BMW quick-acting clamp for holding the measuring sensors precisely in position and measuring without rim run-out compensation.
- **Note:** Any existing quick-acting clamps, e.g. from older F1600s or ML-3000s, must not be used on the BMW KDS.

### 3.8 Rotating / sliding plates

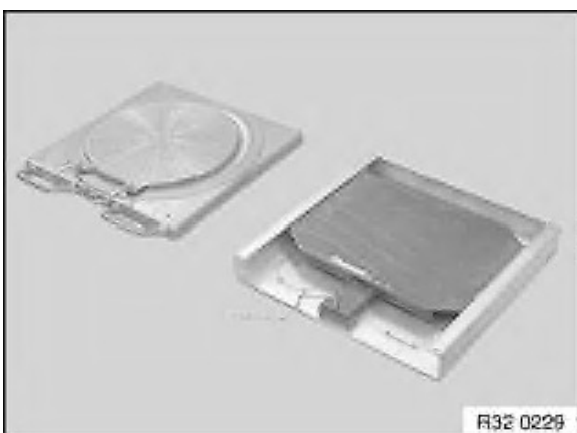

- Electronic precision rotating plates for the front wheels with integrated sensor (360 degree measuring range)
- Stable sliding plates for the rear wheels with a swivelling / rotating top plate
- Accessories: Cover hood for aluminium rotating plates

### 3.9 Sensor pins





- A new BMW light alloy wheel (styling no. 18) has been available as optional equipment from April 1993. When measurements are being made on vehicles with these wheels, new sensor pins are required for the quick-acting clamps of the recommended wheel alignment equipment.
- The new sensor pins are included in the scope of supply for new deliveries of KDS 1 (order number: BS 90 19 11).

### 3.10 Spoiler adapter



- In the case of vehicles with very low spoilers, the sensor beam may be broken by the spoiler between the measuring sensors. This primarily occurs in front of the front axle.
- The spoiler adapter is used here as a connecting element between the measuring equipment clamp and the measuring sensor. Thanks to the adapter, the sensors are placed 50 mm lower, thus allowing the sensor beam to move freely below the spoiler.

### 3.11 Quick-clamping units

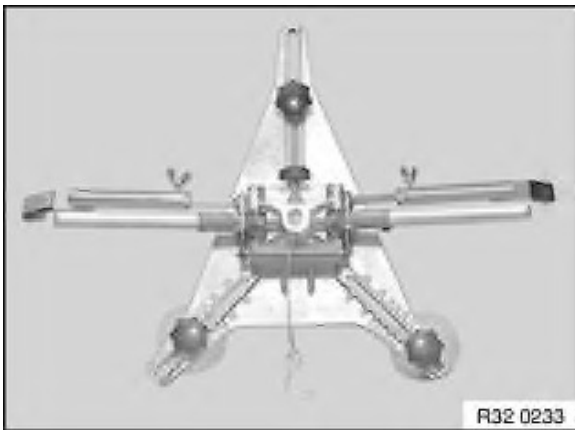

- Quick-clamping units for wheel alignment on non-BMW vehicles with rim run-out compensation.
- Rims without sensors boreholes (rims for BMW vehicles from other manufacturers)

### 3.12 Retainers

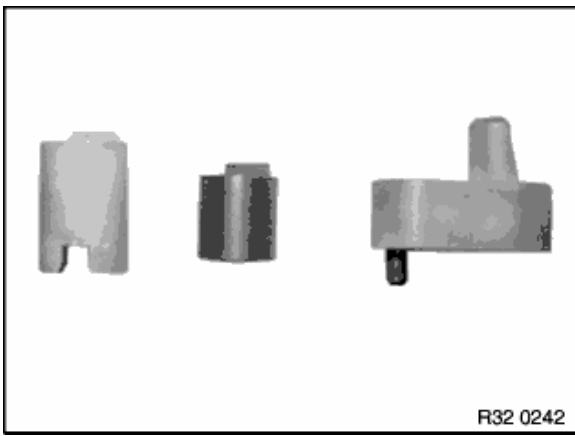

- The most varied clamping options for the measuring equipment are possible thanks to the versatile retainers and the rubber-coated thrust pieces, even on exotic light-alloy rims.

## 4. Workstation

### 4.1 Environment

#### Description:

All lifting platforms currently recommended by BMW (see Workshop Equipment Planning documentation, Issue 11) for wheel alignment meet the requirements for the BMW KDS.

No particular requirements have to be met in respect of the location at which the BMW KDS is used. The measuring device can be installed over working pits or on lifting platforms.

#### Requirements:

- Wheel alignment pits
- Pillar-type lifts with set-down device
- 2 plunger-type lifting platforms with set-down device
- Repair stands with set-down device
- One measuring area (approx. 4.5 m x 7.0 m).
- The rotating plates must be pinned to the platform

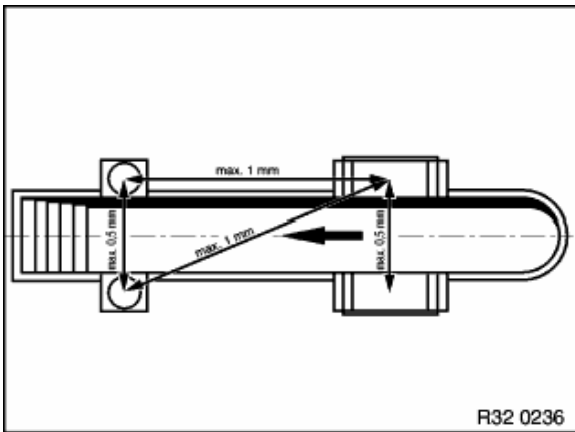

The support surfaces for the rotating and sliding plates may only display the following maximum height difference:

- from left to right  $\pm 0.5$  mm
- from front to back  $\pm 1.0$  mm
- diagonally  $\pm 1.0$  mm.

#### Note:

A difference in the height of the rotary plates of  $\pm 2$  mm from left to right results in a measuring error of  $4.8^\circ$  in the camber.

**As a comparison:** The camber tolerance on the E36 is  $\pm 10'$ . The tyre tread difference or varying tyre pressure cause measuring errors of the same magnitude.

### 4.2 Preconditions for alignment

When carrying out the wheel alignment, the front and rear wheels must be centred on the rotating and sliding plates in order that all wheel suspensions remain free of tension during the steering routine and adjustment work. As a result, the rotating and sliding plates for the relevant wheel bases and track widths of the vehicle to be aligned must be moved.

### 4.3 Measuring tolerance

All measuring tolerances are system tolerances. This means that the sum of all individual tolerances gives the value shown in the example. Example of camber: Quick-acting clamp + measuring sensor + computer = 1' at a measuring range of  $\pm 3^\circ$  (all BMW vehicles are within this measuring range).

### 4.4 Levelling the measuring station

The manufacturers of the BMW KDS (Beissbarth / Bosch) are able to measure the measuring area to the required accuracy using levelling devices. Any "normal" water level is not suitable for this. Lifting platforms must be levelled under load so that the uneven deflection in the travel rails is taken into account.

#### Important:

Adjustment work for the lifting platform concerned must be executed by a specialist (manufacturer's after-sales service).

## 5. Chassis-related terms

### 5.1 Toe-differential angle

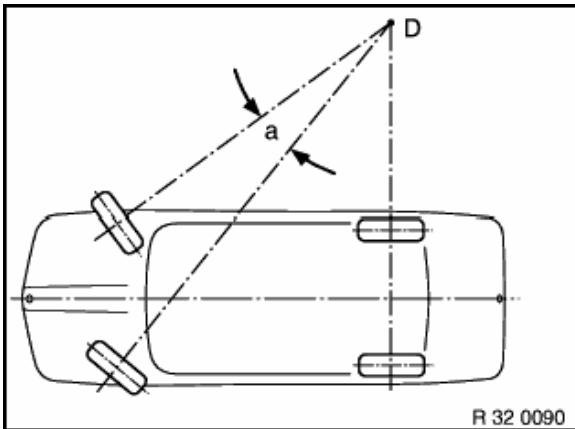

- The toe-differential angle (a) is the angular position of the internal wheel on the curve in relation to the external wheel on the curve when driving round bends. The steering is designed such that the angular position of the wheels in relation to each other changes as the steering angle increases.
- In ideal cases, the wheel axes meet at point D in any steering position (except for straight ahead).

### 5.2 Camber

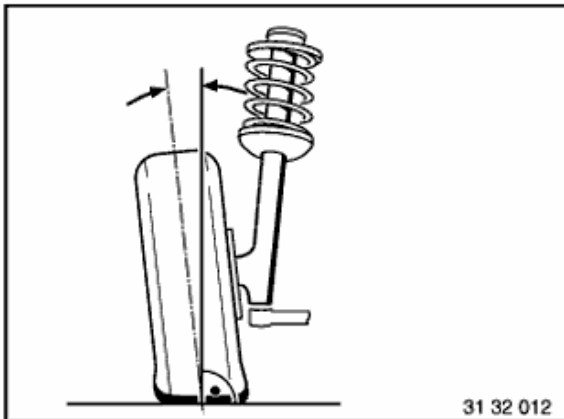

- The camber is the angle of inclination of the wheel in relation to the vertical.

### 5.3 Toe-in

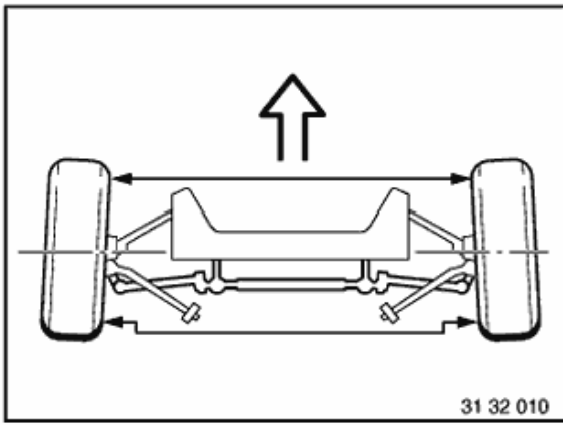

- The toe-in is the reduction in the distance between the front of the wheels and the rear. The toe-in prevents the wheels from moving apart whilst driving (wobbling and grinding).

#### 5.4 Castor

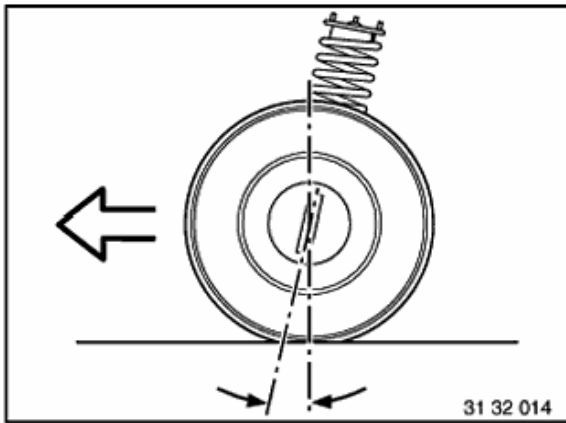

- The castor is the kingpin angle seen from the side in the opposite direction of travel. The line through the centre of the spring strut mount and control arm ball joint corresponds to the kingpin.

#### 5.5 Geometrical drive axis / symmetrical axis

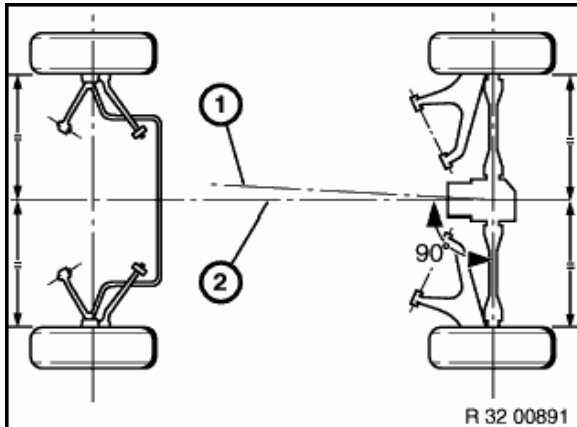

- (1) The geometrical drive axis is the line bisecting the angle of the overall rear wheel toe. The measurements of the front wheels relate to this axis.
- (2) The symmetrical axis represents the centre line through the front and rear axes.

#### 5.6 Wheel displacement angle

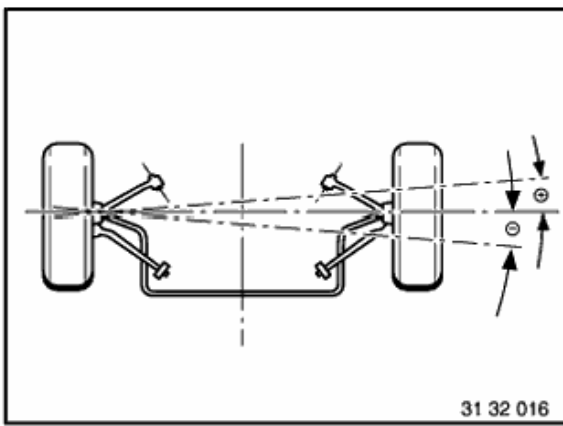

- The wheel displacement angle is the angular deviation of the connecting line of the wheel contact points in relation to a line running at 90 ° to the geometrical drive axis. The wheel displacement angle is positive if the right-hand wheel is displaced to the front, and is negative if it is displaced to the rear.

## 5.7 Kingpin offset

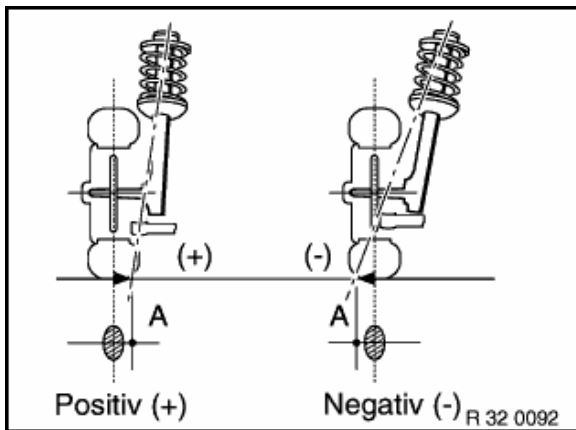

- The kingpin offset is the distance from the centre of the wheel contact point to the contact point of the kingpin extrapolation.

## 6. Wheel suspension

Those parts which connect the wheel to the mostly load-bearing floor elements of the bodywork and guide it in the required direction belong to the wheel suspension. They are connected by axles or other comparable structures and guided by the arms. The wheel suspension plays a decisive role in the handling characteristics of a vehicle. Two main groups have to be distinguished: 1. Rigid axle suspension and 2. Independent wheel suspension.

### 6.1 Rigid axle suspension

#### Description

The rigid axle suspension has a rigid connection between both wheels or wheel pairs. Any change in one wheel is more or less transferred to the other. It is now only fitted as a rear axle, if at all. However it is frequently used for lorries or busses.

#### Advantages

In the event of deflection taking place, there are no changes to the camber or wheel toe. This means: less tyre wear and good track stability.

#### Disadvantages

Non-driven rear axles may also acquire negative camber as well as increasing tyre lateral guidance, thus increasing tyre wear.

### 6.2 Independent wheel suspension

#### Description

#### Advantages

#### Disadvantages

State-of-the-art individual wheel suspension is available on BMW vehicles on the front and rear axles.

Wheels suspended independently from each other have no mutual influence on each other.

Depending on the type, changes may occur in the camber, wheel toe, track width, castor and wheelbase.

This development has its cause in mass inertia, as a reduction in the non-suspended mass improves wheel and ground contact, and the wheel stays better on the road. Control arms and trailing arms, which have to absorb high longitudinal and lateral forces to some extent, are required for guiding independently suspended wheels.

## 7. Wheel alignment / procedure

### 7.1 Measuring options

An overview of all measuring options and values (VA = front axle, HA = rear axle) is shown below.

Measuring options	Measuring accuracy	In measuring range	Total measuring range
Total wheel toe (VA + HA)	± 2'	± 2°	± 18°
Single wheel toe (VA + HA)	± 2'	± 2°	± 9°
Camber (VA + HA)	± 1'	± 3°	± 10°
Wheel displacement (VA)	± 2'	± 2°	± 9°
Geometrical drive axis	± 2'	± 2°	± 9°
Castor	± 4'	± 18°	± 22°
Kingpin inclination	± 4'	± 18°	± 22°
Toe-differential angle	± 4'	± 20°	± 20°
Maximum steering angle (VA )	± 4'	± 60°	± 300°
Maximum steering angle (HA )	± 4'	± 9°	± 9°
Castor correction range	± 4'	± 7°	± 10°

#### Note:

The measuring accuracy details only apply when using the precision rotating and sliding plates as well as the BMW quick-acting clamps.

### 7.2 Preparatory work

Before commencing the measurement, preparatory work must be carried out at the measuring area and on the vehicle (see BMW KDS operating instructions). Preparatory work includes:

- Easy-running rotating and sliding plates
- Aligning the rotating and sliding plates in relation to the track width and wheelbase
- Centering the vehicle on the plates
- Applying the parking brake
- Removing the lock pins on the plates to prevent tension in the chassis under loading
- Checking the rim and tyre size, tread depth, tyre pressure, steering wheel play, wheel bearings and condition of suspension and shock absorbers
- Fastening the measuring equipment to the wheels
- Loading the vehicle according to BMW KDS specifications
- Rock the vehicle firmly with the brakes released to ensure a stable centre position
- Lock the service brake using the brake clamping device

### 7.3 Initial / final measurement

This measurement can be carried out as a program-guided measurement in the same way as any subsequent adjusting work and the final measurement. The sequence of the chassis measuring points to be called up is specified and controlled by the system software. The individual steps comprise:

- Driving straight ahead to correctly record the wheel toe and camber values for the rear axle
- Steering routine for recording the castor, kingpin inclination and toe-differential angle
- Recording the wheel toe and camber of the front axle (adjust the steering centre point in advance)
- Steering routine for measuring the maximum steering angle on the left/right
- Checking the overview of measured values with the setpoint and actual comparison of all measured values

### 7.4 Printing out the data

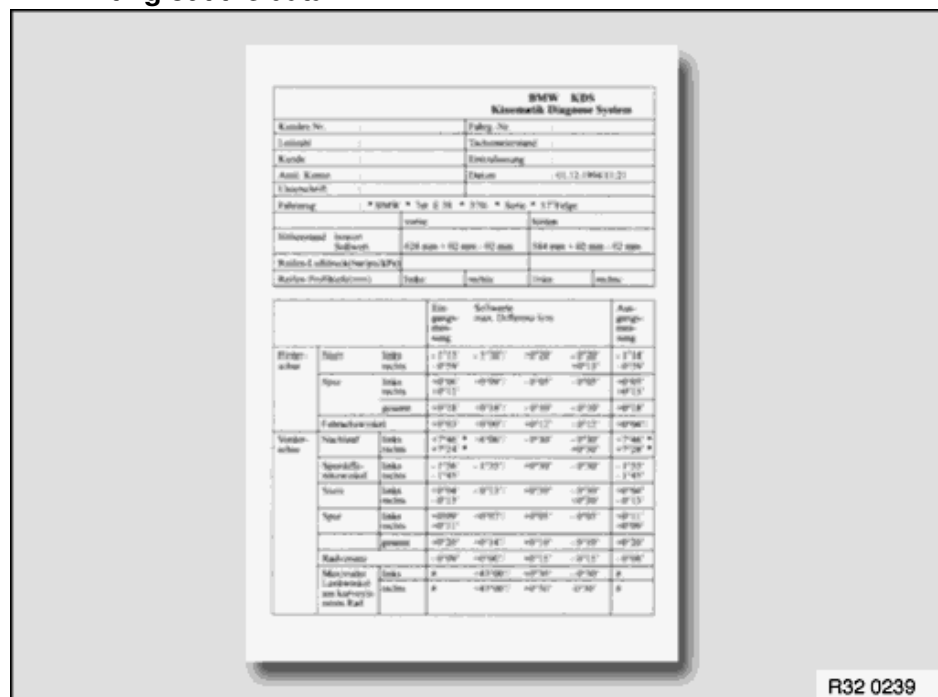

R32 0239

The report printout from the integrated DIN A4 printer is subdivided into three sections:

- Header lines with customer and vehicle identification data --> the customer data entered before beginning the measurement as well as vehicle data are printed out here.
- Centre section with vehicle data --> this includes the make, type, model and vehicle model year defined when the setpoint data record was selected. The values previously measured for height level, tyre pressure and tread depth are also printed in this section.
- The end section with all vehicle alignment values comprises the 3 columns initial measurement, setpoint values and output measurement. The measured values are recorded separately in these three columns.

## 8. Special features

### 8.1 Free wheel alignment

With free wheel alignment the selection and sequence of the measuring points is freely selectable. The following points must be observed for attaining the correct measurement results:

- Carry out all work in the same way as with the program-guided measurement.
- Before measuring the wheel toe and camber values for the rear axle, the steering must be in the "straight ahead" position to ensure that it is perfectly aligned in relation to the longitudinal centre plane of the vehicle.
- Before measuring the single wheel toe values on the front axle, the centre of steering must be established to ensure the correct position of the steering wheel.

### 8.2 System settings

The following settings must only be entered or set once: language, display format, date/time, advertising text, remote control with display, rotating plate selection and printer settings. They remain stored.

## 9. BMW Kinematic Diagnosis System comparison (Bosch - Beissbarth)

	<b>Bosch</b>	<b>Beissbarth</b>
Measured value recording	Infrared	CCD camera
Data transmission	Cable	Infrared / cable
Measuring sensor power supply	Cable	Battery / cable
Remote control	Infrared	Infrared
Remote control with measured value display	Cable	Infrared
Setpoint data memory	Floppy disk	Hard disk
Measured value memory	Always the last vehicle measured	Unlimited vehicle memory
Operating system	---	MS-DOS
Languages	English and one language on request	EN, DE, NI, SV, IT, FR, SP (further languages can be called up)
Update	3.5" floppy disk	3.5" floppy disk using TIS/DIS
Monitor	20"	17"
Computer	---	Pentium
Disk drives	2 x floppy disk	1 x floppy, 1 x CD ROM

## 10. Control modification (menu)

### 10.1 Remote control with display

The following steps show how the remote control with display is activated:

1. Call up the "**Service**" menu in special functions ("**S**" key)
2. Call up the "**Remote control**" sub-menu in the "**Service**" menu.
3. Select the "**Remote control with display**" item in the "**Remote control**" sub-menu - this configuration is retained.

#### Important:

In the case of equipment without remote control, this must be configured to "**No remote control**".

### 10.2 Brief operating instructions

1. Activate the remote control with the "**ON**" button (it may also be switched on during alignment). The title page will appear on the LCD.
2. Select "**Straight ahead**" of the "**Initial measurement**", "**Adjustment work**" or "**Final measurement**" at the measuring equipment cabinet. The steering graphics for "**Straight ahead**" will appear on the LCD.
3. Use the "**Forward arrow**" to change to the next measurement image. Display blocks will appear on the LCD with the designation of the measured value and tolerance bar with the measured value. If the measured value is within the tolerance range, it is shown in dark figures against a light background. If the measured value is outside the tolerance range, it will be shown in inverse video (light figures against a dark background).
4. By pressing the "**F**" key shortly, you can move alternately between the designation of the measured value and the setpoint value with the tolerance inside the display blocks.
5. You can scroll through the measured values using the "**Forward arrow**", "**Backward arrow**" and "**Cancel**" (**red dot**) keys. The function of these keys is identical to that of the keys on the graphics panel.
6. Even with "**Free alignment**", it is possible to scroll through the measured values in the same way as with "**Program-guided alignment**".
7. During measurement, the report print-out can be initiated using the "**Printer**" key. The remote control keys are only active during measurement and adjustment (not during customer data input, vehicle selection etc.).

### 10.3 Display support

- Measured values with a setpoint/actual comparison and tolerance bar (setpoint figures can be displayed with the "**F**" key)



- Steering graphics for steering routines
- Overview of measured values with current setpoint/actual comparison
- Rim run-out compensation
- With all other functions (e.g. customer input), the title illustration appears on the LCD display

**Note:**

If the data transmission from the remote control to the computer is interrupted, the remote control icon in the bottom right-hand corner of the screen changes colour from green to red and the illustration on the LCD display is shown inversely - black turns to white, white to black. This change does not take place in the title illustration. Once the line-of-sight connection has been re-established, the remote control continues to operate from the point of interruption in the program. A continuous visual connection during alignment is therefore not necessary.

- The "**Hour glass**" icon in the LCD display means: "**Please wait**".
- The "**Battery**" icon in the top right-hand corner of the LCD display means that the battery reserve has been reached.
- To switch off the remote control: press the "**F**" key for 5 seconds, then return it to its charging unit or connect it to a charge cable. The title illustration will again appear as a charging check.
- If, during the measurement, the remote control has been placed back in the charging unit, it must be switched on again using the "**ON**" button.

## 11. Updating the software / setpoint data

Floppy disks will no longer be sent to BMW partners who have acquired a "**BMW KDS** (Beissbarth / Bosch)". For cost-related reasons, you can create these disks yourself on the "**DIS-tester**" or on the "**TIS/EPC server**". The data for this is regularly updated on the TIS CD.

### 11.1 Requirements

- BMW KDS (Beissbarth / Bosch)
- TIS CD program status (Beissbarth): from CD 12/95
- EPC program status: from 12/95
- TIS CD program status (Bosch): from CD 08/97
- DIS program status: from V6.0
- 3.5" diskettes, 1.44 MB (Beissbarth 5 diskettes / Bosch 1 diskette)

### 11.2 Procedure (Beissbarth)

1. Go to the "**Administration**" screen
2. Select the **KDS button**
3. Select **Beissbarth**
4. Insert "**Diskette 1**" on request and confirm with "**OK**" (program diskette 1 of 2 is created, label it)
5. Insert "**Diskette 2**" on request and confirm with "**OK**" (program diskette 2 of 2 is created, label it)
6. Insert "**Diskette 3**" on request and confirm with "**OK**" (setpoint data diskette 1 of 3 is created, label it)
7. Insert "**Diskette 4**" on request and confirm with "**OK**" (setpoint data diskette 2 of 3 is created, label it)
8. Insert "**Diskette 5**" on request and confirm with "**OK**" (setpoint data diskette 3 of 3 is created, label it)
9. Perform update and/or setpoint data on the KDS in the usual manner with the diskettes which have just been created.

### 11.3 Procedure (Bosch)

1. Go to the "**Administration**" screen
2. Select the **KDS button**
3. Select **Bosch**
4. Label "**Diskette 3.1**", insert it into the drive on request and confirm with "**OK**" (2x) --> Setpoint data is copied

to the diskettes.

5. Insert setpoint data diskette 3.1 into the 3.1 floppy disk drive, insert operating system diskette 3.0 into the 3.0 drive.
6. Switch on the machine in the usual manner.

**Important:**

When creating the KDS diskettes, all data on the diskettes used is overwritten.

**Note:**

In the event of an error, a corresponding message is shown and the program is cancelled completely. The procedure must be run from the beginning again and all data on the diskette will be deleted. A new diskette may have to be used.

## 12. Creating, copying and editing setpoint data

### 12.1 Copying

- Press the "**C**" button and select the vehicle to be copied.
- Select the "**Edit setpoint data**" menu item from the special functions. Create a new vehicle in the usual manner. The setpoint values for the last vehicle selected will appear in the data input screen. Enter the data and save the data record.

### 12.2 Creating

- Press the "**C**" button and select the "**Edit setpoint data**" menu item from the special functions. Create a new vehicle in the usual manner. An empty data input screen will appear. Enter the data and save the data record.

### 12.3 Editing

- Factory-programmed setpoint data can neither be deleted nor modified. If this data does need to be modified, a new vehicle with modified setpoint data must be created. New vehicles created by the user are identified by a "+" in the selection menu. These vehicles can be deleted by the user using the "-" key or modified using the "<>" key. These keys only appear if vehicles have been entered by the user.

## 13. Special functions

### 13.1 Customer-specific printer report header

The sub-item "**Customer-specific text**" must be called up in the "**Special functions**" menu. An input screen will appear on the monitor. This input screen must be filled out with the name and address and stored with the "**S**" screen key. The text entered is inserted into the report header.

### 13.2 Adjusting options

- Call up the "**Service**" menu in the special functions ("**S**" key).
- Select the "**Wheel toe adjustment**" item or the "**Camber adjustment**" item from the "**Adjustment**" sub-menu. The toe and camber adjustment program will guide the user step by step through the adjustment using text and images. The measuring deviation for each measuring sensor will be shown on the screen when the adjustment has been completed.
- You can store the adjustment values in the measuring sensor using the "**Store**" key or you can quit the program with the "**Red dot key**" without saving them (check). The adjustment values can be printed out.

### 13.3 Rotating plate test

- Call up the "**Service**" menu in the special functions ("**S**" key).
- Call up the "**Rotating plate**" item in the "**Service**" menu. Turn the left-hand and right-hand rotating plate and check the display on the screen. Important: The measuring range is  $\pm 306$  degrees.

### 13.4 Viewing and deleting customer entries from database

- Call up the menu item "**Delete**" in the "**Database**" menu in the special functions. The data input screen will appear. Fill in the search fields with the data to be deleted.
- Use the "-" button to delete this data record. A new data record can then be highlighted and deleted with the digital pen.

- You can scroll through the entire database with the "**Arrow up**" and "**Arrow down**" keys.
- You can quit the delete function by pressing the cancel key (red dot).

#### 14. Modifications within program

Further modifications were carried out within the program which only slightly change the program sequence but which optimise the alignment in respect of comfort and speed. This is described below:

- Optimisation of the rim run-out compensation in respect of speed.
- Optimisation of the steering routines: Highlighted values within the gate can still be corrected. The message "**Rotating plates not connected**" no longer causes the steering routine to be cancelled. Further measurements can be carried out after the rotating plates have been connected.
- Standardisation of screen colours with the colours on the tablet.
- Addition of texts in several foreign languages.
- Elimination of program-related and cosmetic faults.
- Electronic water level.
- Omission of kingpin inclination measurement.

#### 15. Faults

##### 15.1 Tyre faults

Fault	Effect
1 Wheel toe, camber, toe-differential angle and castor not correct	1 Severe tyre squeaking even at relatively low speeds
2 Excessive toe-in and excessive positive camber	2 Tyres are worn down on one outside edge in the longitudinal direction
3 Excessive negative camber	3 Tyre wear on inside edge
4 Worn front-axle suspension on front-wheel-drive vehicles	4 Increased noise / Vehicle pulls on one side when accelerating
5 Incorrect wheel alignment	5 Wheels scrubbing / Tyre surface shows feathering in the tread
6 Play in the suspension due to mechanical parts (suspension, steering)	6 Washout / Wobbling of front wheels
7 Tyre pressure too low	7 Outside tyre surface wear

##### 15.2 Front axle faults

Fault	Cause	Remedy
1. Toe deviation	a) Vehicle not in normal position	a) Correct height level
	b) Tie rod(s) bent	b) Replace tie rod(s)
	c) Tie rod ball joints worn	c) Replace tie rod(s)
	d) Rubber mount in control arm defective	d) Replace control arm

2. Camber deviation: The camber is fixed during the design stage and cannot be adjusted.	a) Rubber mount in control arm defective	a) Replace control arm
	b) Control arm deformed	b) Replace control arm
	c) Spring strut deformed	c) Replace spring strut
	d) Traction strut worn	d) Replace control arm
	e) Spring deflection too great	e) Replace coil spring, height level
	f) Front axle carrier deformed	f) Replace front axle carrier
	g) Spring strut mount deformed	g) Repair forward structure
	h) Distortion in the floor assembly (engine bracket)	h) Repair body
3. Castor deviation: The castor is fixed during the design stage and cannot be adjusted.	a) Rubber mount for tension / traction strut defective	a) Replace rubber mount
	b) Tension / traction strut deformed	b) Replace tension / traction strut
	c) Control arm deformed	c) Replace control arm
	d) Spring strut deformed	d) Replace spring strut
	e) Wheelhouse deformed (spring strut mount)	e) Repair forward structure
	f) Distortion in the floor assembly (engine bracket)	f) Repair body
4. Toe-differential angle deviation	Requirement: camber and castor are correct	
	a) Tie rods unevenly adjusted	a) Set wheel toe on left and right to identical values
5. Wheel displacement deviation	Requirement: Front wheels have same single toe in relation to the geometrical axis	
	a) Front axle carrier deformed	a) Replace front axle carrier
	b) Engine bracket deformed	b) Repair body
	c) Control arm deformed	c) Replace control arm
	d) Tension / traction strut deformed	d) Replace tension / traction strut

### 15.3 Rear axle faults

<b>Fault</b>	<b>Cause</b>	<b>Remedy</b>
1. Camber deviation	a) Vehicle not in normal position: spring deflection too great	a) Correct height level

	b) Rubber mount on rear axle carrier defective	b) Replace rubber mount
	c) Rear axle carrier deformed	c) Check rear axle carrier and replace, if necessary
	d) Control arm deformed	d) Check control arm and replace, if necessary
	e) Traction strut deformed	e) Check traction strut and replace, if necessary
	f) Distortion in the floor assembly	f) Repair body
	g) Swinging arm deformed	g) Replace swinging arm
2. Rear wheel position is not correct	a) Rear axle carrier has been shifted laterally	a) Check the rubber mounts on the rear axle carrier and replace, if necessary
	b) Distortion in the floor assembly	b) Repair body
3. Toe deviation	a) Vehicle not in normal position, i.e. spring deflection too great	a) Correct height level
	b) Rubber mount in rear axle carrier defective	b) Replace rubber mount
	c) Control arm deformed	c) Replace control arm
	d) Rubber mount and swinging arm defective	d) Replace swinging arm
	e) Rear axle carrier deformed	e) Check rear axle carrier and replace, if necessary
	f) Traction strut deformed	f) Check traction strut and replace, if necessary
4. Deviation from the geometrical drive axis	Requirement: Total wheel toe is correct	
	a) Distortion in the floor assembly	a) Repair body

**Further details on the "Kinematic Diagnosis System" can be found in the operating instructions for the BMW KDS (Beissbarth / Bosch).**

**Functional and system descriptions are not subject to change. Parts availability and immediate ordering availability cannot be derived from this information. The specialist departments will be providing further details at the relevant time.**