

---

# Table of Contents

## The Charging System

<b>Subject</b>	<b>Page</b>
The Purpose of The Charging System.....	3
System Components .....	3
Brush Type Generators .....	4
Brushless Type Generators .....	6
Voltage Regulator .....	7
Charging System Principle of Operation .....	9
Single Phase AC Voltage Generation .....	10
Three Phase AC Voltage Generation .....	11
Voltage Rectification .....	12
Three Phase Voltage Regulation .....	13
Charge System Indicator .....	16
Generator Diagnosis.....	18
Review Questions .....	22

---

## Charging Systems

**Model: All**

**Production Date: All**

### Objectives

After completing this module you should be able to:

- Explain the purpose of the charging system.
- Identify the components of the charging system.
- Describe how AC current is rectified to DC current.
- Explain the differences in the types of generators.

## Purpose of The Charging System

The purpose of the charging system is to convert the mechanical energy of the engine into electrical energy that is used to recharge the battery and power the electrical accessories. When the engine is first started, the battery(s) supplies all the current required by the starting and ignition systems.

As the battery drain continues and engine speed increases the charging system is able to produce more voltage than the battery can deliver. When this occurs, the electrons from the charging device are able to flow in a reverse direction through the battery's positive terminal. The charging device now supplies the electrical system's load requirements and recharges the battery.

The charging system consists of:

- Battery
- Generator
- Drive Belt
- Rectifier Assembly
- Voltage Regulator
- Charge Indicator
- Ignition Switch
- Cables and Wiring Harness

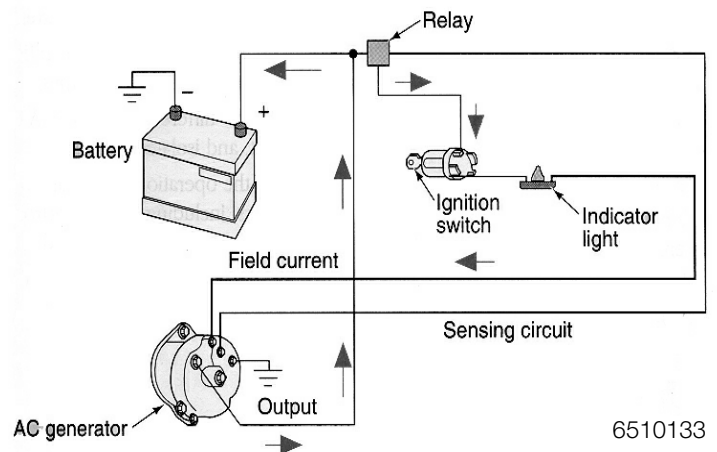

## System Components

### Battery

The Battery is the primary EMF source in the automobile. The automotive battery is an electromechanical device that provides the potential difference (voltage). The battery does not store electrical energy. It stores chemical energy that is converted to electrical energy as it discharges.

### Generator

The Generator produces free electrons necessary to charge the battery. The electron flow is produced through inductance, a magnetized rotor spinning inside a stator. The generator produces AC voltage which is converted to DC voltage or rectified.

Generator styles:

- Brush Type
- Brushless Type

**Note:**

In an attempt to standardize terminology in the industry, the term alternator is being replaced with generator. Often an alternator is referred to as an AC generator.

Air or liquid (coolant) is used for generator cooling.

## Brush Type

Brush Type generators consist of the following main components:

- Generator Housing
- Stator Assembly
- Rotor Assembly

### Generator Housing

The Housing is made of two pieces of die-cast aluminum. Aluminum is used because it is non-magnetic, light weight and provides good heat dissipation.

Bearings for support of the rotor assembly are mounted in the front and rear housings.

### Stator Assembly

The Stator is fixed to the housing of the generator and does not turn. It contains three main sets of windings wrapped in slots around a laminated, circular iron frame. Each of the three windings has the same number of coils as the rotor has pairs of north and south poles. The coils of each winding are evenly spaced around the core.

The three sets of windings alternate and overlap as they pass through the core in order to produce the required phase angles.

Each group of windings occupy one third of the stator, or 120 degrees of the circle.

The voltage produced by each loop of the stator is at a different phase angle, as a result the output of the stator is divided into three phases.

Two common methods of connecting the windings are:

- Y Connection
- Delta Connection

The parallel path of the Delta connection makes more current available.

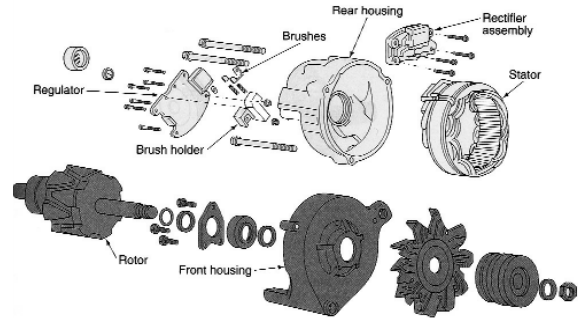

6510101.jpg

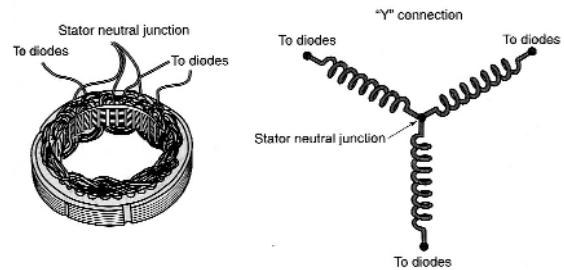

Y Connection

6510120.jpg

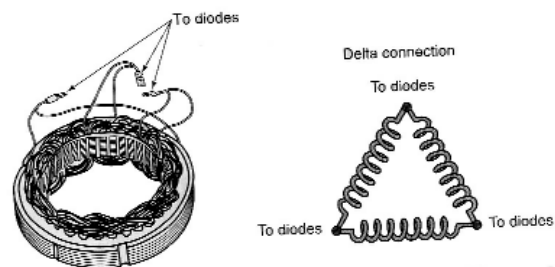

Delta Connection

6510121.jpg

## Rotor Assembly

The Rotor Assembly consists of the rotor shaft, a winding around an iron core, two pole pieces and slip rings.

The rotor shaft is pressed into the core, then six-fingered malleable iron pole pieces are assembled on the shaft against each end of the winding core.

The pole pieces are placed so that the fingers mesh but do not touch. When direct current is passed through the field coil winding, the fingers become alternately North and South poles.

As a result of this arrangement of poles, the magnetic flux lines will move in opposite directions between adjacent poles. (Flux lines always move from North to South.)

This arrangement provides for several alternating magnetic fields to intersect the stator as the rotor is turning.

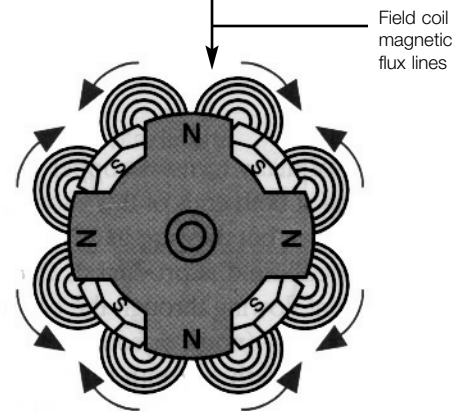
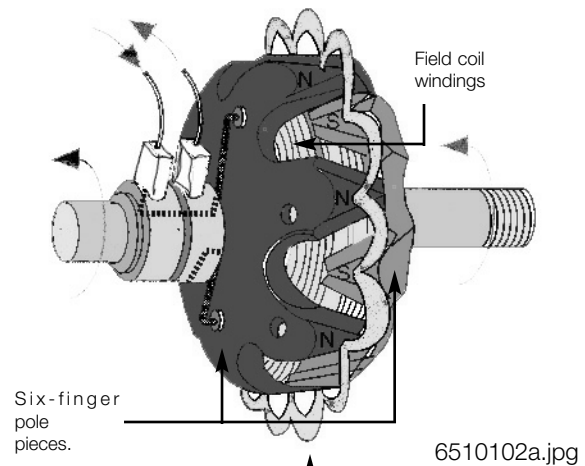

A slip ring pressed on to the rotor shaft is connected to the two ends of the field winding.

Two brushes are held by springs against the slip rings. One brush is connected through a switch to the battery B+, the other to the voltage regulator.

The brushes conduct only the field current (2 to 5 amps).

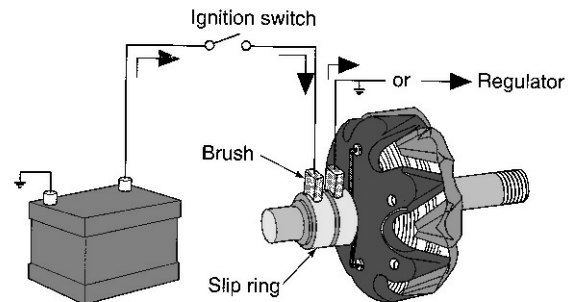

## Brushless Type

Brushless Type generators are liquid cooled (coolant) and consist of the following main components:

- Generator Housing
- Stator Assembly
- Rotor Assembly

### Generator Housing Water Cooled

The Water Cooled Generator is housed in an encapsulated metal shell enclosure. The enclosure is installed an aluminum shell.

The space between the inner surface of the shell and the outer surface of the generator creates a water jacket that engine coolant flows through. Coolant flows from the engine into the shell through internal ports and exits via hose connections.

Liquid cooling minimizes noise generation through elimination of generator cooling fan

### Stator Assembly

Although different in appearance the Stator Assembly in a brushless generator performs the same functions as the brush type.

### Rotor Assembly

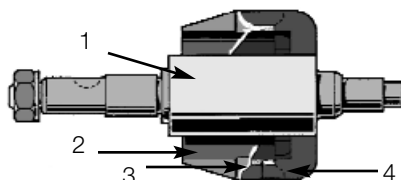

1. Rotor Shaft With Pole Core
2. Left Pole-Finger Crown
3. Non-Magnetic Retaining Ring
4. Right Pole-Finger Crown

The brushless generator Rotor does not contain the field coil. The pole-finger crowns rotate around a fixed field coil and are magnetized by the flux field of the field coil.

The two crowns form claw-pole half sections and are retained by a non-magnetic ring positioned below the pole fingers.

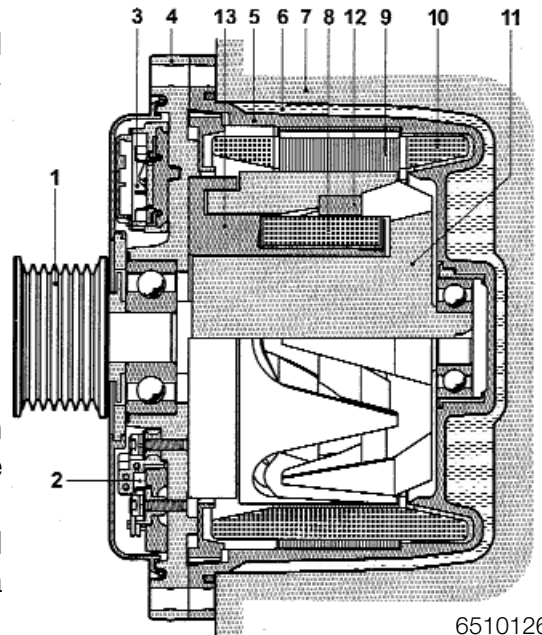

6510126

1. Pulley
2. Rectifier
3. Voltage Regulator
4. Drive End Shield
5. Generator Housing
6. Coolant
7. Coolant Housing
8. Field Winding
9. Stator Housing
10. Stator Winding
11. Rotor
12. Non Magnetic Intermediate Ring
13. Rotor Pole

---

## **Rectifier Assembly**

The Rectifier Assembly consists of six diodes, a pair of diodes for each stator winding. Each pair contain one positive biased diode and one negative biased diode. By using a pair of diodes that are reversed biased to each other, rectification of both sides of the AC sine wave is achieved. The negative biased diodes allow for conducting current from the negative side of the AC sine wave and putting this current into the circuit as positive current. The use of positive and negative biased diodes provide for full wave rectification because both halves of the sine wave are used.

## **Drive Belt**

It is the function of the Drive Belt to transfer rotating energy from the engine to the generator. The drive belt rotates the rotor, spinning the magnetic field. A loose belt can inhibit charging system efficiency and a belt that too tight causes early bearing failure.

## **Voltage Regulator**

Voltage Regulators prevent excessively high voltage output of the generator. Excessive voltage would cause damage to the battery (through overcharging), light bulbs, motors, and particularly sensitive electronic components.

The regulator prevents these problems by limiting the current output of the generator.

Two types of regulators that are used:

- Standard Regulator
- Multifunction Controller

### **Standard Regulator**

Electronic Voltage Regulators are mounted internally in the back of the generator assembly. Generator output is controlled by varying the amount of time the field coil is energized.

The duty cycle of the field coil ground side is varied based on the demand placed on the electrical system.

The electronic voltage regulator compares field current supply voltage (from the stator windings through the diode trio) against a set voltage level ( using a zener diode).

As the field current supply voltage surpasses the zener diode's breakdown voltage, the field current to the rotor is switched off. When the field current voltage to the rotor is off, the generator is not producing voltage. A rapid switching of the field current allows a fixed voltage output to be maintained. Additional diodes in the regulator, prevent current flow when the ignition is off preventing battery drain.

---

## Multifunction Controller

In addition to voltage regulation, the Multi-function Control electronic regulator provides the following features:

- Load response during start-up.
- Load response during driving.
- Fault display (under voltage, drive belt breakage, field coil interruption).

**Note:**

Multi-function Control electronic regulators are available with and without start load response. The only difference is the time limitation of the rated current during the start procedure.

The start-up load response system provides for the alternator exciter current (field coil) to be started by a transistor two seconds after the battery indicator goes out. This means that engine start-up is unaffected by generator induced drag.

The load response during driving ensures that when large current consumers are switched on the generator output increases linearly allowing the DME/EML system to stabilize the engine speed and/or modify injection time if necessary.

## Charge Indicator

The purpose of the Charge Indicator is to advise the driver that the vehicle's electrical system is not operating at peak efficiency and service should be performed.

The charge indicator operates differently depending on which type of regulator the vehicle is equipped with.

### Standard Regulator

The charge indicator operates on the basis of opposing voltages. If there is no output through the diode trio, then the lamp circuit is completed to ground through the rotor field. Diode output applies voltage to the previously grounded side of the bulb, turning the bulb off (No current flow with equal voltage on both sides of the bulb).

### Multifunction Controller

The charge indicator is activated by an electronic switch integrated in the controller. This internal switch receives its voltage supply from KL15 of the 2 pin generator connector. The controller measures internally the difference in voltage between KL30 and KL15 and switches the indicator circuit low in case of a fault.

---

## **Ignition Switch**

The Ignition Switch provides initial power for the field circuit of the alternator, reducing the time required for the field to develop the magnetic field. Depending on which type of regulator is employed the ignition switch supplies power to the charge indicator to check bulb integrity.

## **Cables and Wiring Harness**

The Cables and Wiring Harness are used to deliver the voltage produced by the generator to the battery for storage, and to vehicle systems to supplement battery voltage.

## **Charging System Principles of Operation**

Charging Systems (Brush or Brushless) use the principle of electromagnetic induction to generate electrical power. Electromagnetic induction occurs in a generator when a magnetic field is rotated within a stationary conductor. The magnetic field can be generated by permanent magnets or as in the case of the automotive generator by powerful electromagnets.

Passing electric current through a wire or winding causes a magnetic field to surround the wire or winding. The number of turns in the winding and the magnitude of the current flowing through the winding determine the magnetic field strength.

The strength of the field is further increased by surrounding the coil with pole pieces. The poles will take on the polarity (North or South) of the side of the coil they touch or the ones they are closest to. The combined windings (field coil) and pole pieces are referred to as the rotor. Output of the generator is regulated through control of field coil intensity.

An examination of single phase AC voltage generation, will aid in the understanding of 3 phase AC voltage generation.

## Single-Phase AC Voltage Generation

Single Phase AC Voltage Generation requires one stator frame with windings and one magnetic field (North and South pole pieces).

As the North pole of the rotor pole piece approaches the winding of the stator, induced voltage level in the stator begins to rise. The closer the North pole gets to the stator winding the higher the induced voltage. As the North pole reaches  $90^\circ$  to the stator winding the maximum amount of flux lines are acting on the winding, induced voltage is at its highest positive value (1/4 turn).

The rotor continues to rotate and the North pole gets further away from the winding. The voltage drops, until 0 voltage is induced through the stator (1/2 turn).

With the South pole now approaching the winding voltage begins to increase negatively. When the South pole reaches  $90^\circ$  to the winding, again the maximum amount of flux lines are acting on the winding and induced voltage is at its greatest negative value (3/4 turn).

The South pole continues to travel farther away from the winding decreasing the negative voltage value until 0 voltage is again reached (1 full turn).

This comprises one cycle or  $360^\circ$  rotation of the magnetic field.

**Sine wave produced by a single winding of the stator during a single revolution of one pair of pole pieces is called single phase voltage.**

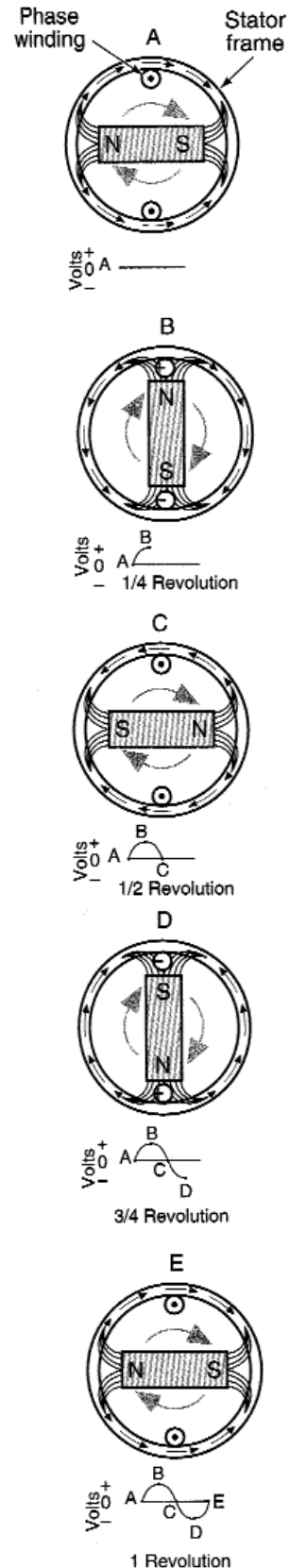

## Three-Phase AC Voltage Generation

Most AC generators use either a twelve or a fourteen pole rotor. Each pair of poles (North and South) produce one complete sine wave in each winding per revolution.

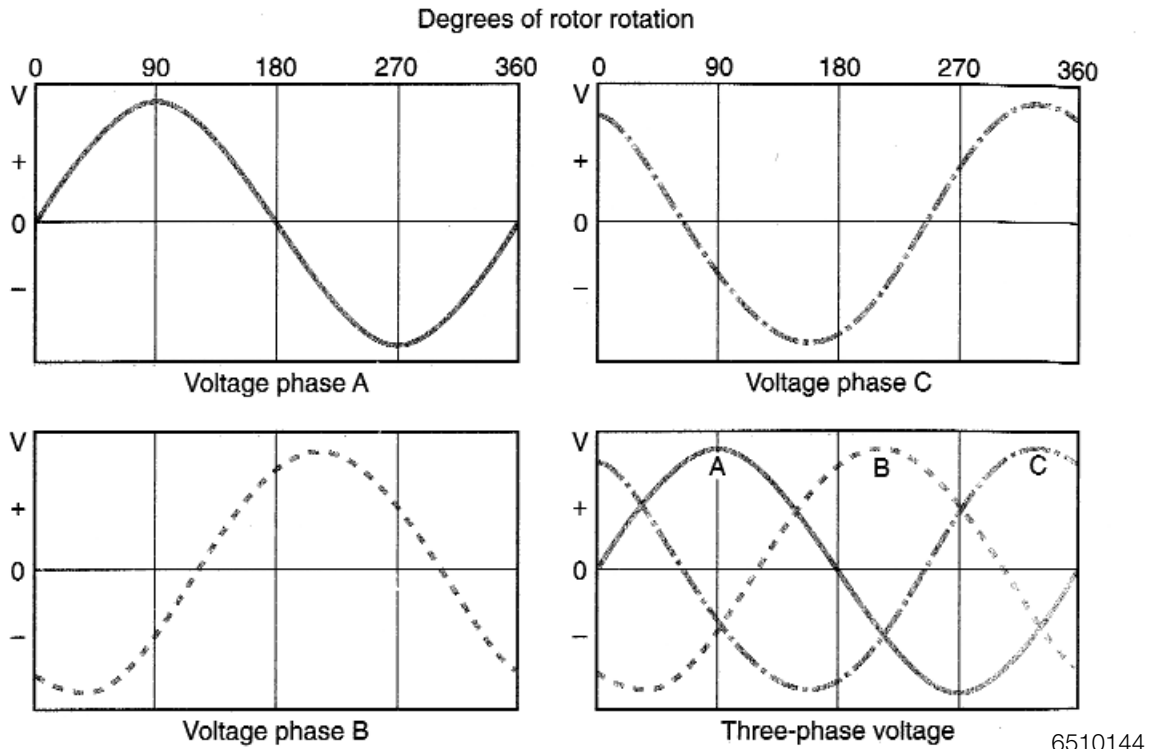

6510144

Voltage of each stator winding is added together to create three-phase voltage

During one revolution a fourteen pole rotor will produce seven sine waves. (The stator has one winding (coil) for each pair of rotors.)

The rotor generates three overlapping sine wave voltage cycles in the stator (one rotor three sets of windings in the stator).

The total output would be twenty one sine wave cycles per revolution. (3 sets of stator windings, each with 7 coils)

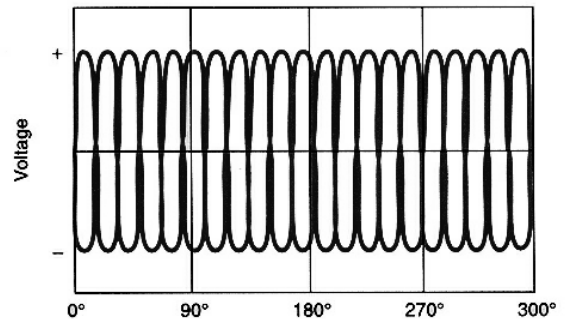

Sine wave cycle of a fourteen pole rotor and three phase stator.

6510122.jpg

## Voltage Rectification

The battery and the electrical system cannot store or use the 3-phase AC voltage produced by a generator, it must be rectified or converted to DC voltage.

A diode rectifier bridge is used to make the conversion.

The diode is similar to a non-return or one way valve which permits the passage of a fluid or gas in only one direction.

In a simple conversion the rectifier diode suppresses the negative half waves and allows only positive half waves to pass.

To make use of the negative value half waves full rectification is applied.

Full rectification of the negative half waves invert them into positive half waves.

The result is a rectified pulsating direct current.

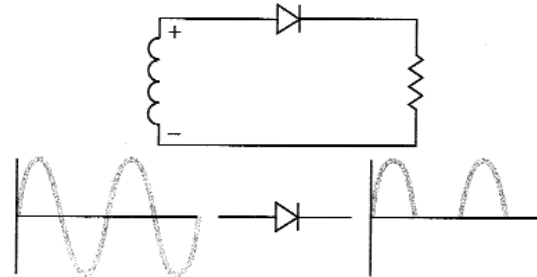

6510143

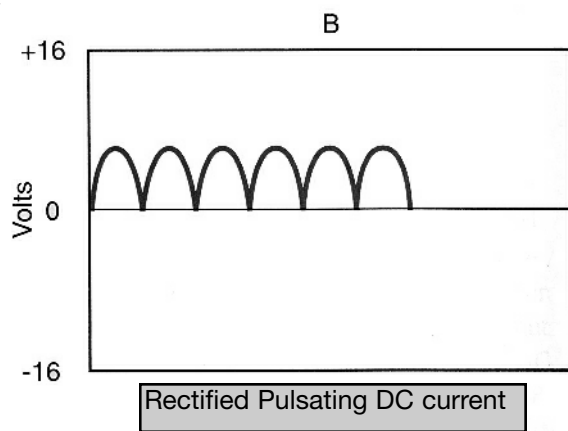

6510137

## Three-Phase Voltage Rectification

Six diodes are used to achieve three-phase AC voltage rectification. Three diodes are positive biased and three are negative biased.

The positive half-waves pass through the positive biased diodes and the negative half-waves through the negative biased diodes.

Diode rectification of the negative half-waves invert them into positive half-waves.

With full rectification DC voltage supplied to vehicle by generator is not ideally smooth, but exhibits a slight ripple. This ripple is further smoothed by the battery which is connected in parallel with the generator.

The rectifier diodes in the generator not only convert the current but also prevent battery discharging through the 3 phase windings of the stator. Current flow can only take place from the generator to the battery.

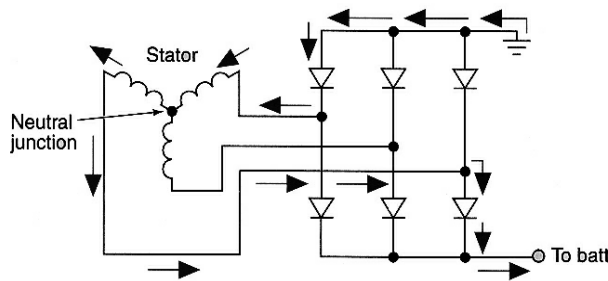

6510134

**Current flow through Y wound stator.**

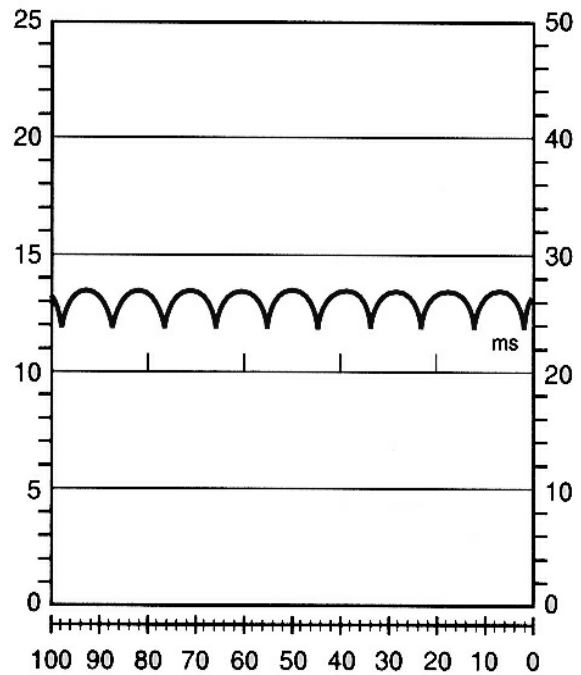

6510123.jpg

**Rectified AC output has a ripple as seen on oscilloscope.**

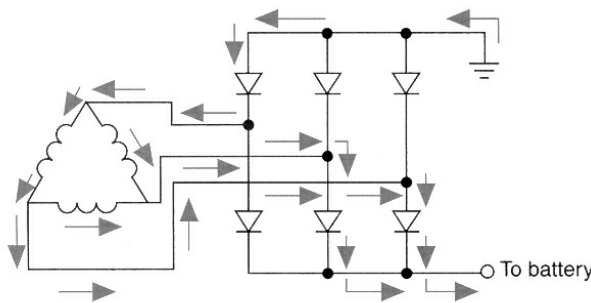

6510135

**Current flow through Delta wound stator**

# Voltage Regulation

## Standard Regulator

The Electronic Regulator uses a zener diode that blocks current flow until a specified voltage is obtained.

Sensing current from terminal 2 passes through a thermistor to the zener diode (D2). As the system voltage exceeds the breakdown voltage of the zener diode, current flows through the zener diode turning transistor 2 (TR2) on. With TR2 on transistor 1 (TR1) is shut off.

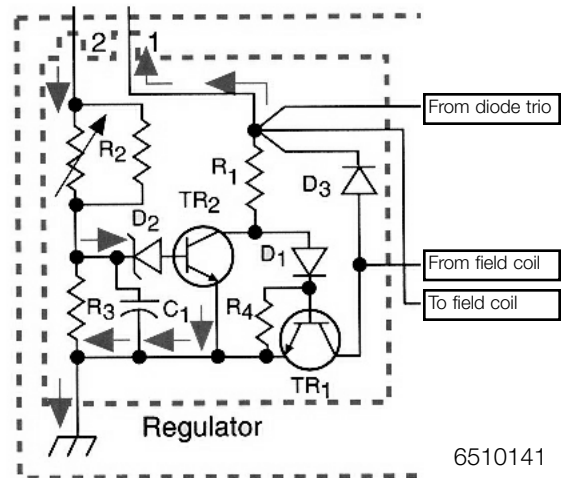

6510141

Transistor 1 controls field current to the rotor. With TR1 off no current flows to the field coil and the generator has no output.

A voltage drop below the breakdown voltage of the zener diode stops the current flow to TR2 which turns on TR1.

Voltage is again applied to the field allowing the generator to produce voltage.

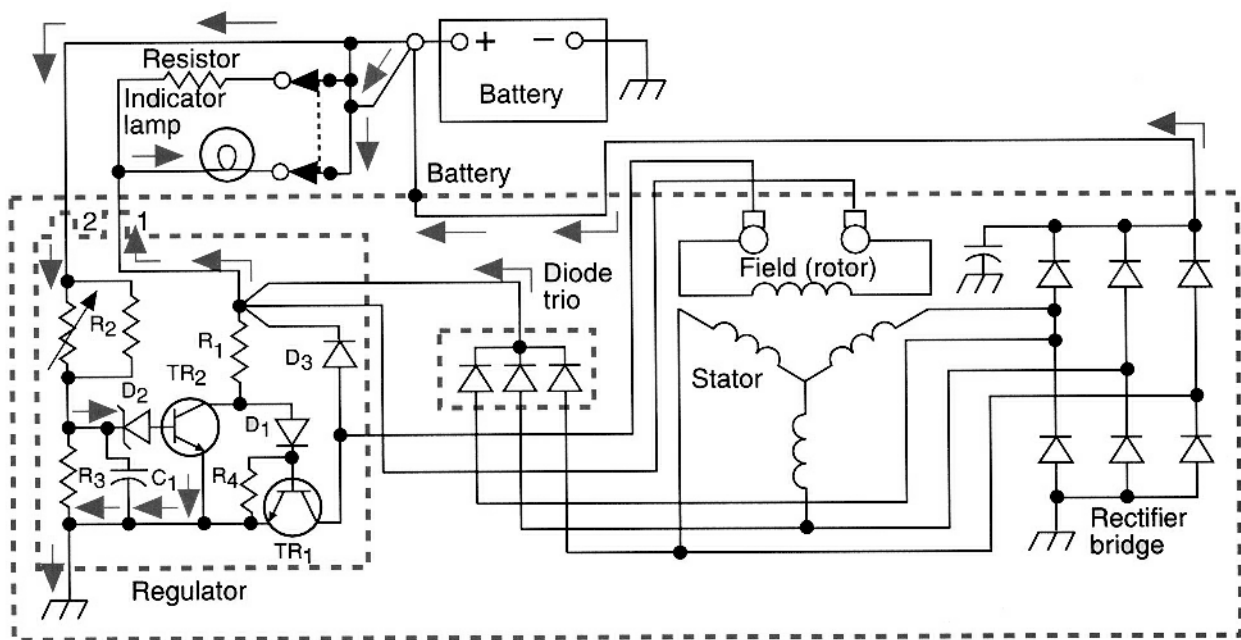

Field coil off, no charging

## Multifunction Controller

The Multifunction Controller regulates voltage in the same manner as the standard voltage regulator. Regulation is through duty cycle control of the field coil.

The differences as compared to the standard regulator are:

- Manner in which malfunction indicator lamp is controlled.
- Connections to wiring harness.

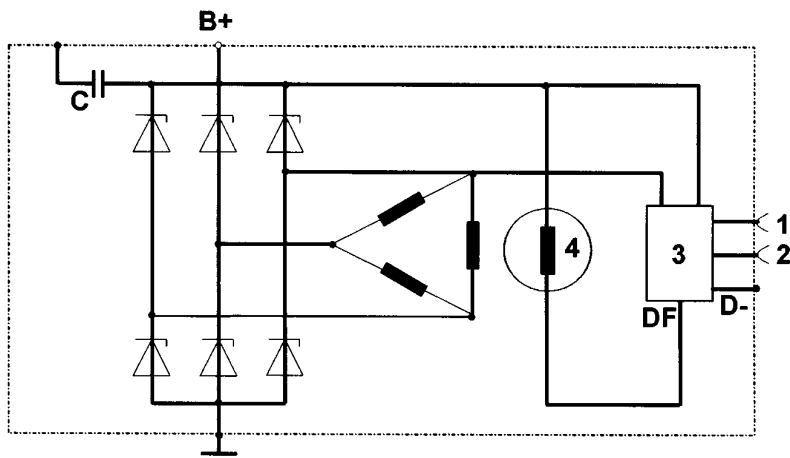

**Terminal 1**  
KL 15 from fused source.

**Terminal 2**  
D+ (KL61) to DME.

**B+**  
Generator output to Battery.

6510129

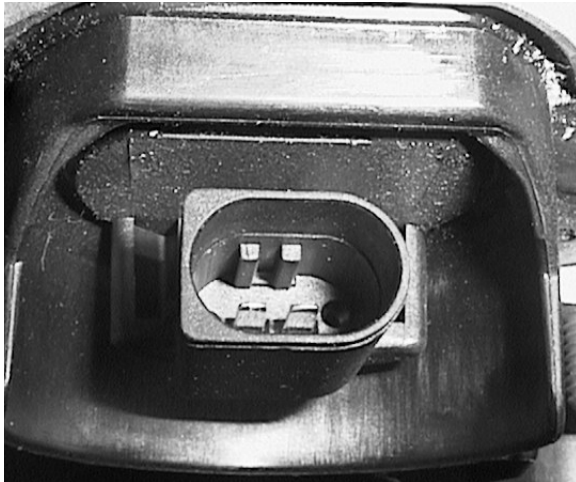

Two Pin wiring harness connector

6510130

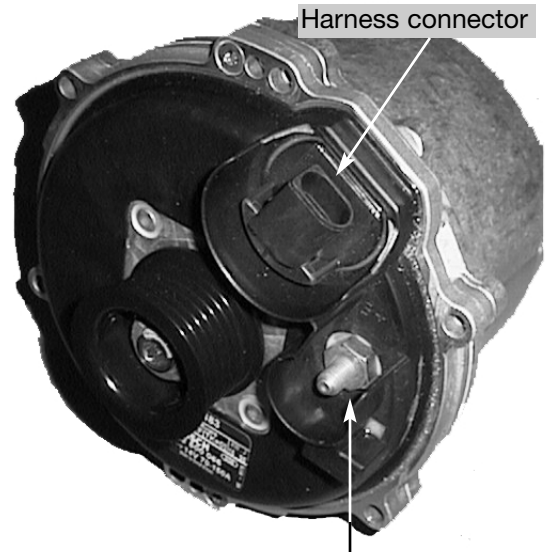

B+ connection

# Charge Indicator System

## Standard Regulator

The Charging System Indicator light operates on the principle of opposing voltage. Battery voltage is supplied to one side of the light bulb, the other side of the bulb is connected to the voltage regulator. With the key turned on, power is sent to the light bulb, through the regulator. No voltage is being produced by the stator, so there is no voltage from the diode trio. This lack of voltage from the diode trio, allows the voltage from the ignition switch to flow through the regulator to ground. This completes the circuit allowing the charge indicator bulb to burn.

As the generator begins to produce voltage, the output of the diode trio equals battery voltage. This equal voltage is supplied to the light bulb. With equal voltage on each side of the light bulb, no current can flow and the light is turned off.

 Current path through light to ground, no charging. Light is on

 Current path through diode trio to light bulb. Generator charging. Light is out.

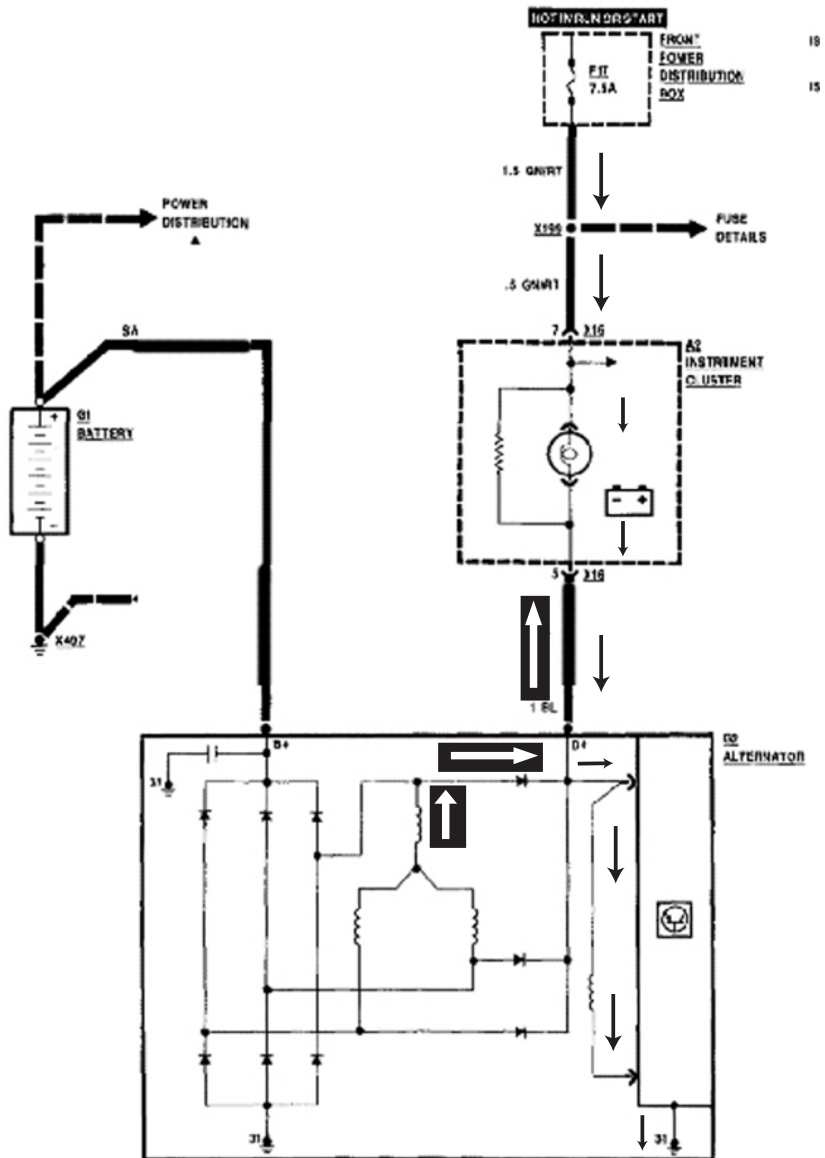

65101100c

## Multifunction Controller

The charge indicator light is activated by means of an electronic switch integrated into the controller. This switch receives its voltage supply from terminal 15 on the 2 or 3 pin connector on the generator. Terminal D+ is replaced by an isolated electronic terminal 61E in generators with a multifunction controller. The task on this terminal is to activate the battery charge indicator lamp and to indicate to the various loads that the generator is in charge mode.

The indicator lamp is supplied with voltage via terminal 15 from the instrument cluster. The lamp is illuminated when the voltage at terminal 61E is below 1.5v and goes out when the voltage is above 8v.

The indicator is on during the following conditions:

- Key on, engine off
- Generator not charging
- Failure of drive belt
- Interruption of field coil
- Controller overvoltage
- Break in charging cable

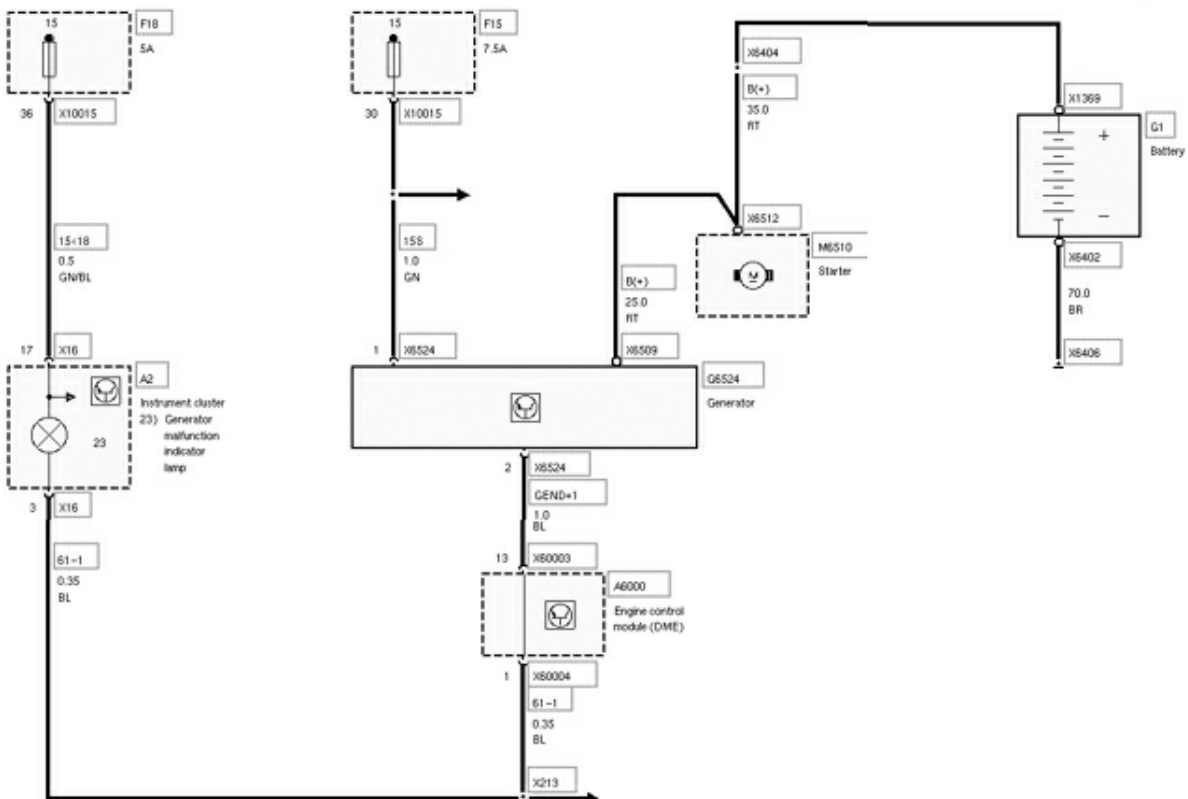

## Generator Diagnosis

Before beginning any generator diagnosis, ensure that the battery is in good condition and has passed all testing procedures. A weak or defective battery will influence the generator testing.

The generator may be tested using:

- DISplus
- VAT testing equipment.

### Testing Generator With DISplus

#### Workshop Hint

Before beginning diagnostic procedures on the charging system do the following:

- Run engine at idle speed for about 5 minutes.
- Switch off all electrical loads.

This is done to ensure the battery is charged to such a level that the generator will not be fully utilized and that loads required during starting (e.g. starter, secondary air pump) will be already switched off.

Two modes of testing are available when using DISplus.

- Testing using Test Plan
- Testing using Preset Measurement

### Testing Generator Using Test Plan

Testing the charging system using a test plan is the more complete method of testing. When selecting this mode of testing, other components in the charging system are tested in addition to the generator.

Test plans available:

- Generator (Checks voltage and current output)
- Wiring from generator to battery (Performs voltage drop test)
- Charge indicator lamp (Condition of bulb, wiring and signal to bulb)
- ON delay and Start ON delay (If applicable)
- Ground side circuit wiring (Voltage drop test)

Sub-tests may be available with some of the component testing.

There are many advantages to using the test plan.

1. Complete system testing.
2. Functional description of system on screen.
3. Proper wiring diagrams provided during testing.
4. Test instructions and notes.
5. Instructions for proper test set-up.
6. Display of nominal values.
7. Solutions.

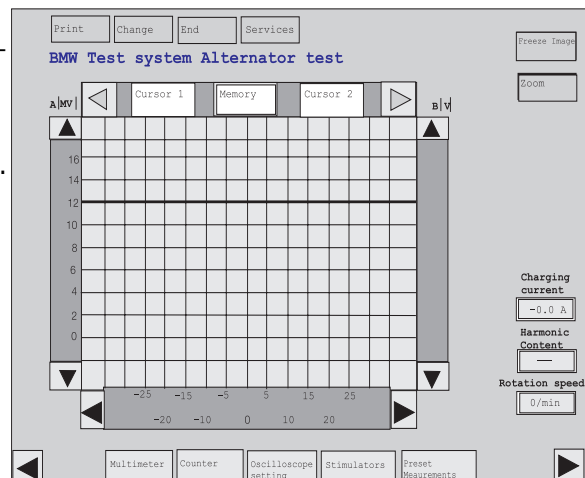

## Testing Generator Using Measurement System

Enter the measurement system and select **Preset Measurements**.

Instruction on the proper hook-ups required are available through the **HELP** button, selecting **Help using Preset Measurement**.

The oscilloscope will display pre-configured for the testing.

Diagnostic information available through oscilloscope.

- Voltage Graph.
- Charging Current.
- Harmonic Content.
- Rotation Speed (Engine RPM).

### Harmonic Content

This is an expression of AC voltage contained in DC voltage.

The higher the percentage of harmonic content the larger the amount of residual AC voltage in the DC voltage.

High residual AC voltage is caused by weak or failing diodes in the generator. Generators which have harmonic content readings higher than specified (In TIS) should be replaced.

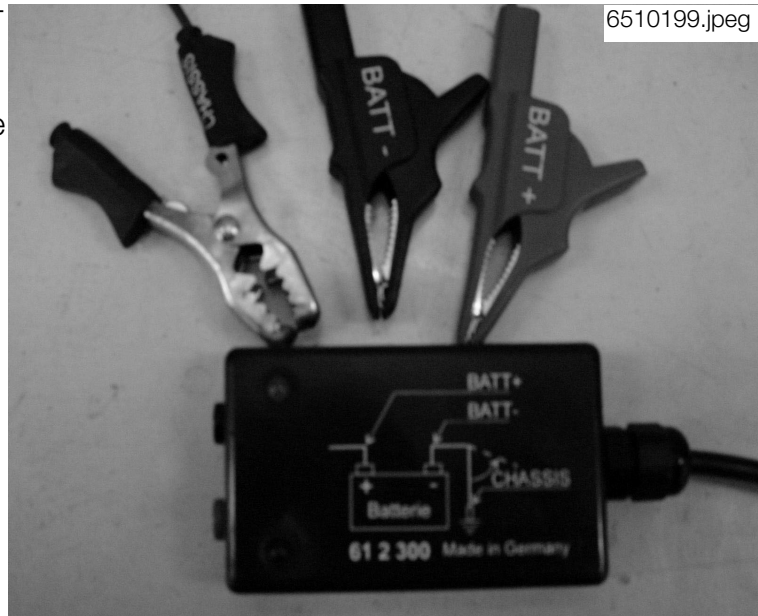

6510199.jpeg

65101105.eps

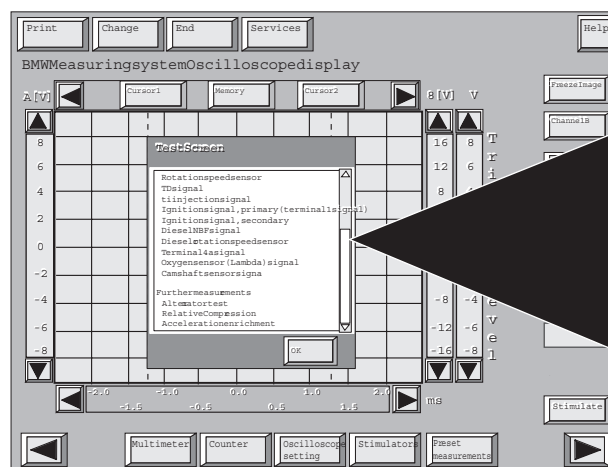

### Signal Tests

- \* Wire Tests
- \* Potentiometer Tests

### Signal Measurements

- \* Status Diagnostic Socket
- \* Status of OBD Socket
- \* Engine Speed Sensor Signal
- \* TD Signal
- \* TI Injection Signal
- \* Ignition Signal, Primary (Terminal 1 Signal)
- \* Ignition Signal, Secondary
- \* Diesel NBF Signal
- \* Diesel Engine Speed Sensor Signal
- \* Terminal 4a Signal
- \* Oxygen Sensor (Lambda) Signal
- \* Idle Actuator Signals
- \* Throttle Valve Potentiometer Signal
- \* Camshaft Sensor Signal

### Futher Measurements

- \* Alternator Test
- \* Absolute Compression
- \* Relative Compression
- \* Smooth Running
- \* Xenon Headlight Test Up to 8/99
- \* Xenon Headlight Test from 9/98

---

## Workshop Exercise

1.

Vehicle Model: \_\_\_\_\_

Perform Vehicle voltage check using Preset Measurement, Status Diagnostic Socket (or OBD Socket): \_\_\_\_\_

Print Results: \_\_\_\_\_

2.

Vehicle Model: \_\_\_\_\_

Perform generator test using Preset Measurement, Alternator Test: using Normal:

Engine RPM: \_\_\_\_\_

Charging Current: \_\_\_\_\_

Harmonic Content: \_\_\_\_\_

What is the nominal value for the harmonic content: \_\_\_\_\_

3.

Vehicle Model: \_\_\_\_\_

Perform generator test using Preset Measurement, Alternator Test: using Direct Method:

Engine RPM: \_\_\_\_\_

Charging Current: \_\_\_\_\_

Harmonic Content: \_\_\_\_\_

What is the nominal value for the harmonic content: \_\_\_\_\_

---

4.

Vehicle Model: \_\_\_\_\_

Perform generator testing using Test Plan: \_\_\_\_\_

Compare results with Preset Measurements: \_\_\_\_\_

Perform On Delay Test Plan: \_\_\_\_\_

Perform Start ON delay Test Plan: \_\_\_\_\_

Perform charge indicator light Test Plan: \_\_\_\_\_

Perform Voltage Drop test on Ground side of circuit as per Test Plan: \_\_\_\_\_

---

---

---

---

Charging System Notes:

---

---

---

---

---

---

---

---

---

## Review Questions

1. Name the major components of the charging system.  
A. \_\_\_\_\_ B. \_\_\_\_\_  
C. \_\_\_\_\_ D. \_\_\_\_\_  
E. \_\_\_\_\_ F. \_\_\_\_\_  
G. \_\_\_\_\_ H. \_\_\_\_\_
2. A rotor assembly has 7 pairs of North and South Poles. How many coil windings will each winding in the stator contain? \_\_\_\_\_
3. What is the purpose of the slip rings and brushes? \_\_\_\_\_  
\_\_\_\_\_
4. Why are field coil windings in a brushless generator contained in the housing instead of the rotor assembly? \_\_\_\_\_
5. Why are some generators now liquid cooled? \_\_\_\_\_  
\_\_\_\_\_
6. What functions does the multifunction controller perform? \_\_\_\_\_  
\_\_\_\_\_  
\_\_\_\_\_
7. The strength of a magnetic field is influenced by what two factors? \_\_\_\_\_  
\_\_\_\_\_
8. How are the negative half waves converted to positive half waves? \_\_\_\_\_  
\_\_\_\_\_
9. What is the biasing of the diodes used in three phase rectification? \_\_\_\_\_  
\_\_\_\_\_
10. How does the standard voltage regulator control generator output? \_\_\_\_\_  
\_\_\_\_\_  
\_\_\_\_\_
11. Explain the operation of the charge indicator lamp with a standard voltage regulator.  
\_\_\_\_\_  
\_\_\_\_\_
12. Explain harmonic content. \_\_\_\_\_  
\_\_\_\_\_