

Remove brake disk (brake line remains connected), refer to 34 11 220.

Remove ABS pulse generator.

Lift out sealing cap with screwdriver. Do not reuse cap!

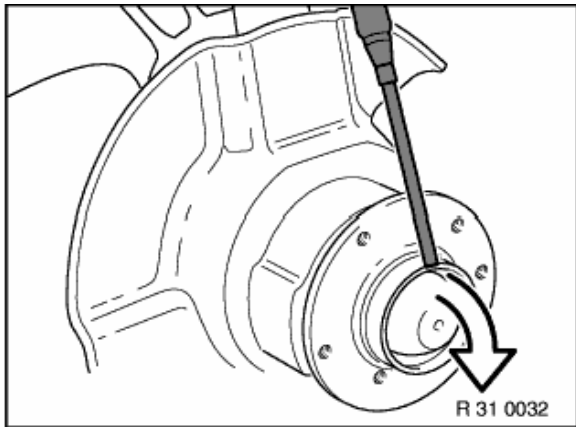

Peen down retainer on collar nut.

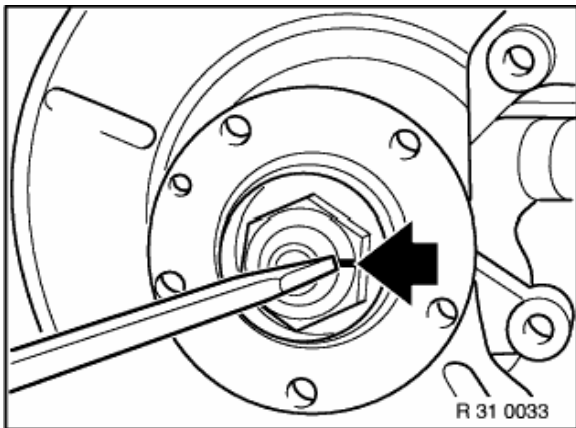

Unfasten nut with special tool 31 2 080.
Do not reuse nut!

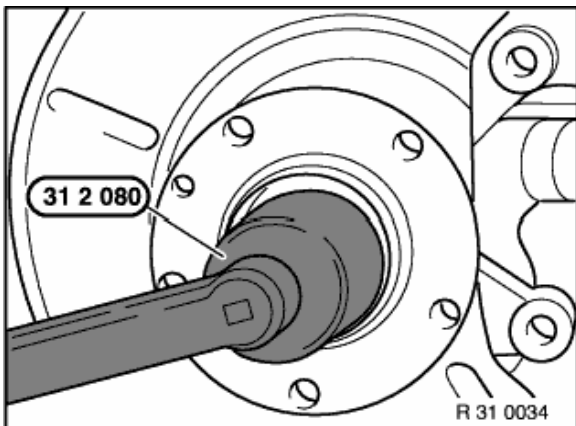

Caution!

Do not reuse bearing unit after disassembly.



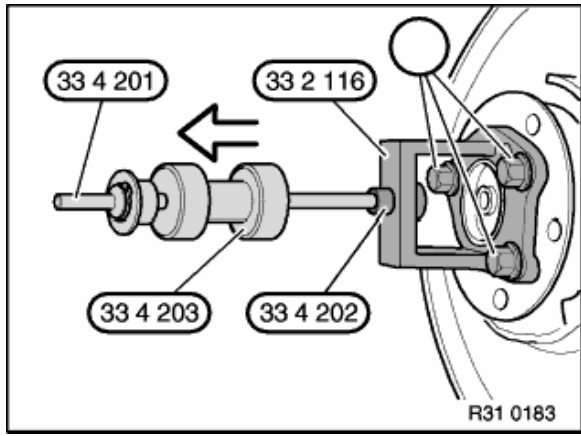

Pull off bearing unit with special tool 33 2 116 / 33 4 201 / 202 / 203 and wheel studs (1).

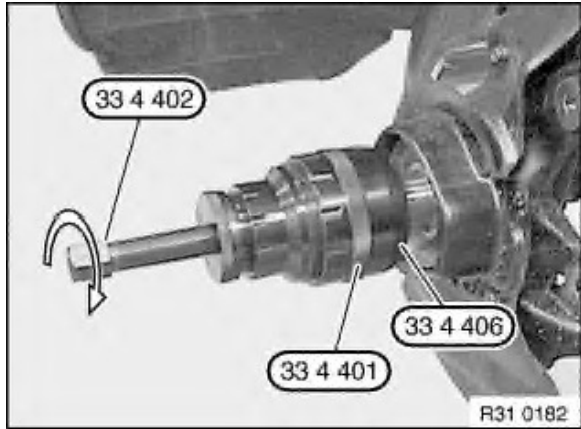

If necessary, pull inner bearing race off axle stub.

Attach special tool 33 4 406 / 401 to inner bearing race and compress until special tool can still just be turned.

Withdraw inner bearing race with special tool 33 4 402.

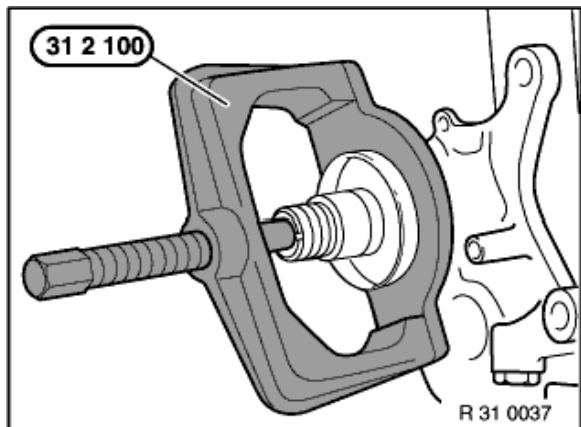

Inner bearing race can also be removed with special tool 31 2 100.

Remove guard plate. Remove inner bearing race and dust guard with special tool 31 2 100.

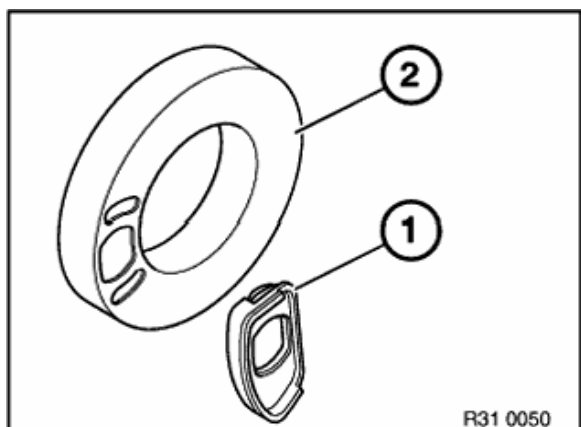

Fit gasket (1) to new dust cover (2).

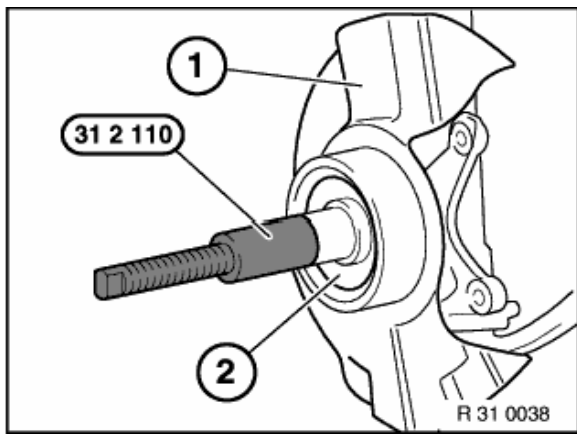

Fit guard plate (1). Fit new dust cover (2).
Bore in dust cover must be aligned with bore in steering knuckle.
Tighten special tool 31 2 110 firmly down.

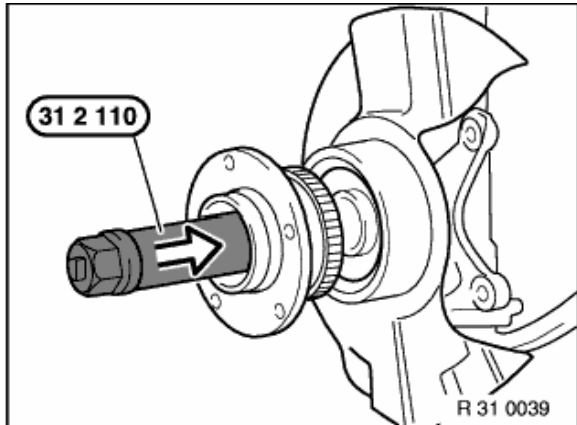

Slide on new bearing unit and fit using special tool 31 2 110.

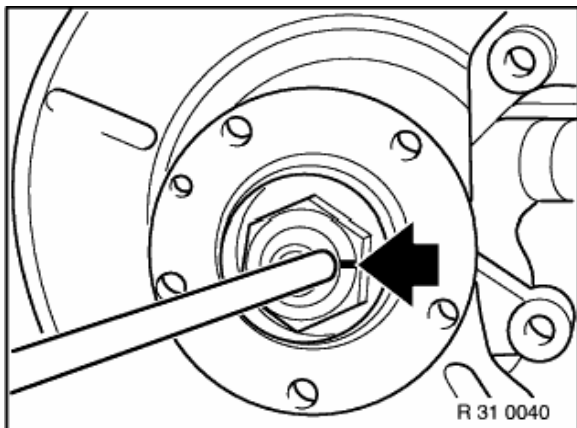

Tighten new collar nut to specified torque,
refer to Technical Data 31 21 1AZ,
and calk.



Caution!

The collar nut must be secured in the groove by means of calking!

Install new cap with sealing compound, refer to BMW Parts Service.

