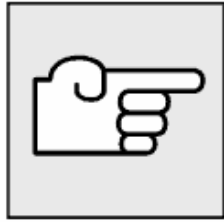

*Note:*

On version with remote control for central locking:  
If necessary, disconnect negative lead from battery.

*Note:*

There are five different versions of the interior rearview mirror:

- (A) Version without cable (X) with full foot
- (B) Version with cable (X) and with plug cover
- (C) Version without cable (X) and with mirror arm end caps
- (D) Version with cable (X) and with mirror arm end caps
- (E) Version with rain sensor and with mirror arm end caps

Version with cable (X) for:

- Automatic dim action (electro-chrome technology) for interior rearview mirror
- Remote control (infrared or radio)
- Garage door opener
- Rain sensor
- Fogging sensor

**Important!**

Do not snap out the interior rearview mirror (1) towards the rear (windscreen breakage).

Do not under any circumstances twist the interior rearview mirror when removing.

Twisting the mirror off the mirror mount will damage the rear catch.

If the rear catch is damaged, the mirror will be loose while it is installed.

**Removal of version (B):**

Version with automatic dim action (electro-chrome technology) for interior mirror and/or remote control:

Lever out plug cover and disconnect plug connection.

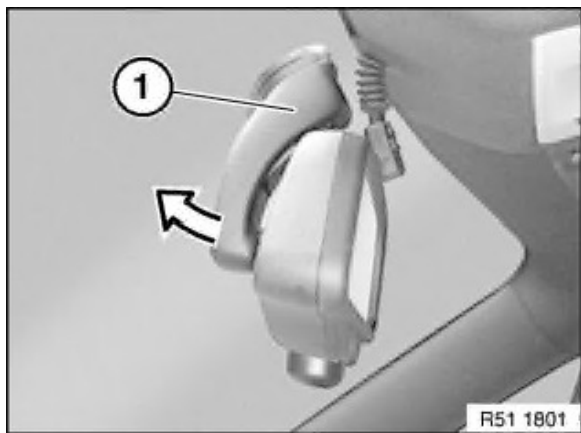

### Important!

Do not remove interior mirror (1) towards rear or by twisting (risk of damage).

Snap out interior mirror (1) from mirror mount towards front by striking with ball of thumb and remove.

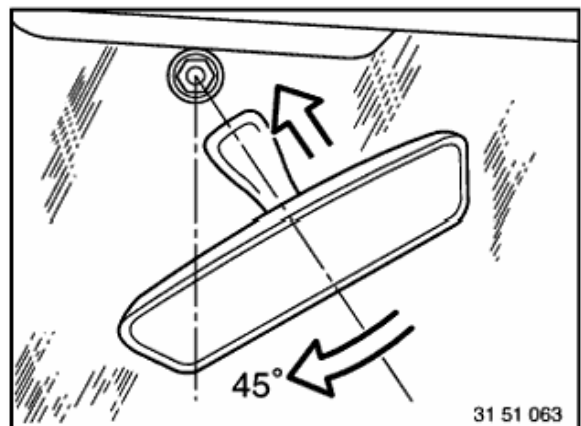

### Installation:

1. Twist mirror foot by approx. 45° and fit to mirror mount.
2. Turn mirror foot until it engages on mirror base.

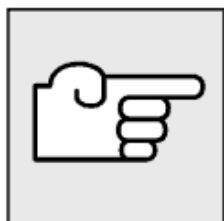

Only replace with version with remote control for central locking:

### Installation:

Initialize all transmitters (ignition keys), refer to Owner's Handbook.

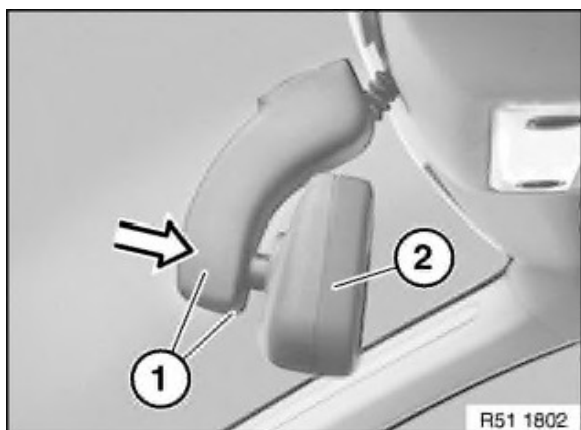

### Removal of versions (C) and (D):

Press end caps (1) towards mirror housing (2); this releases clip connection of both caps (1).

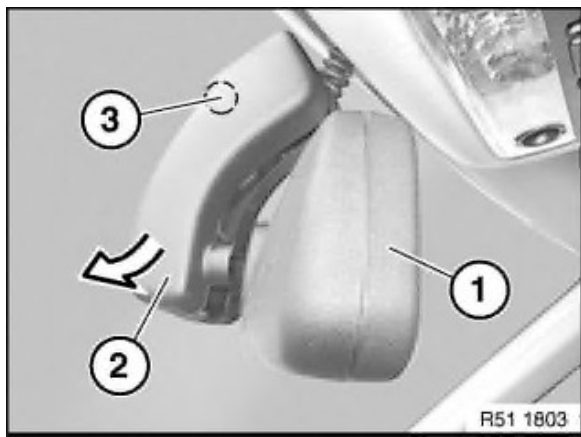

Twist mirror (1) at an angle towards front and right/top.  
Swivel left end cap (2) off ball neck in direction of arrow; this detaches the engagement clip (3) from the metal foot.

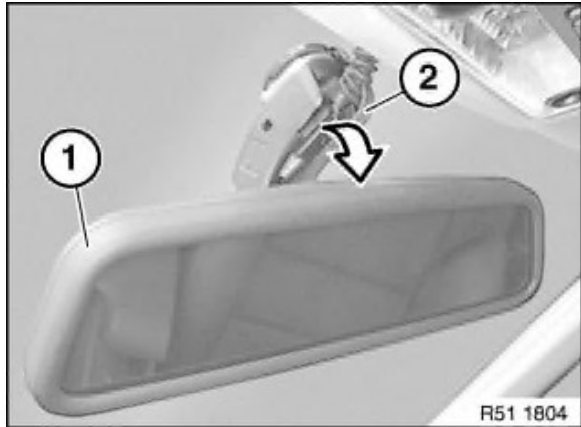

Twist mirror (1) at an angle towards front and left/top.  
Swivel right end cap (2) off ball neck in direction of arrow; this detaches the engagement clip from the metal foot.

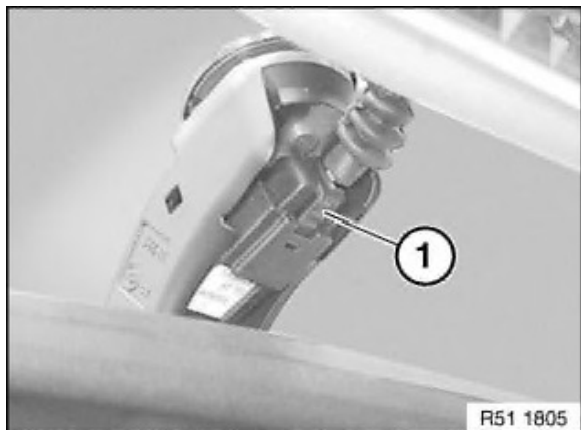

Disconnect plug connection (1).

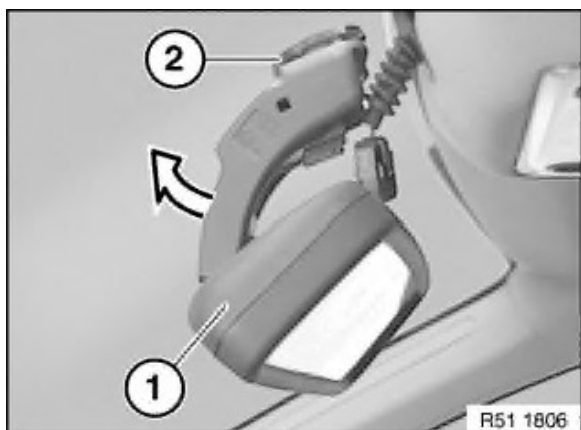

**Important!**

Do not remove interior mirror (1) towards rear or by twisting (risk of damage).

Snap out interior mirror (1) from mirror mount (2) towards front by striking with ball of thumb and remove.

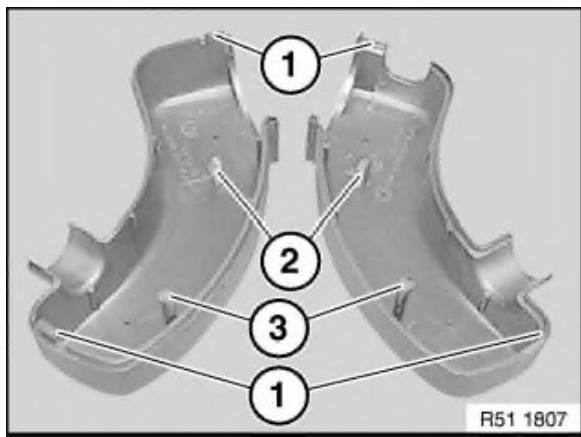

*Installation:*

Clips (1) and retaining hooks (2) of end caps (3) must not be damaged, replace if necessary.

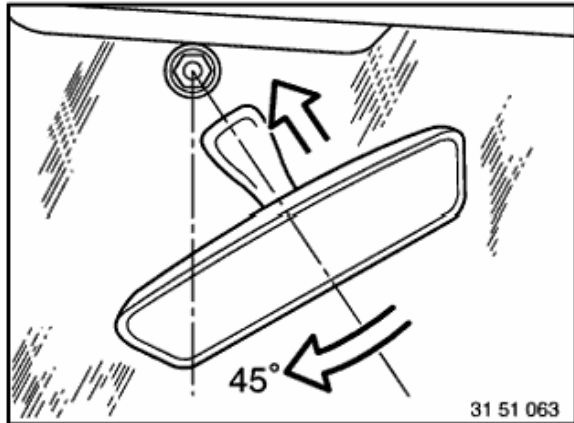

*Installation:*

1. Twist mirror foot by approx. 45° and fit to mirror mount.
2. Turn mirror foot until it engages on mirror base.

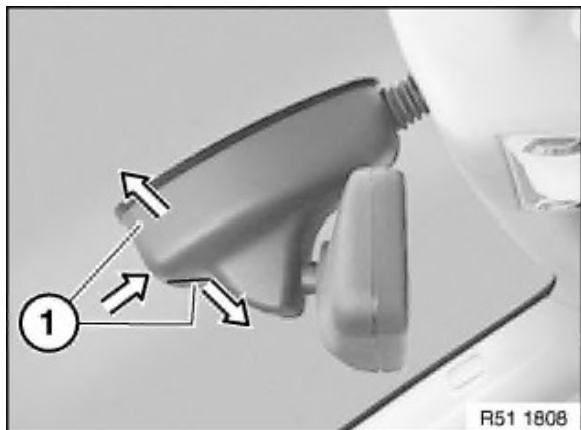

**Removal of version (E) with rain sensor:**

Press on end caps (1) and at same time press them apart; this releases clip connection of both caps (1).

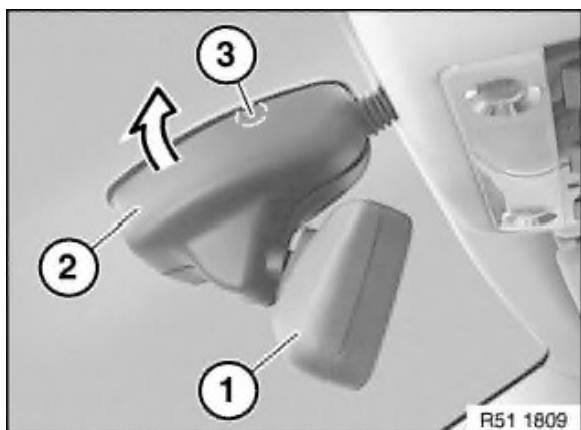

Twist mirror (1) at an angle towards front and right/top.

Swivel left end cap (2) off ball neck in direction of arrow; this detaches the engagement clip (3) from the metal foot.

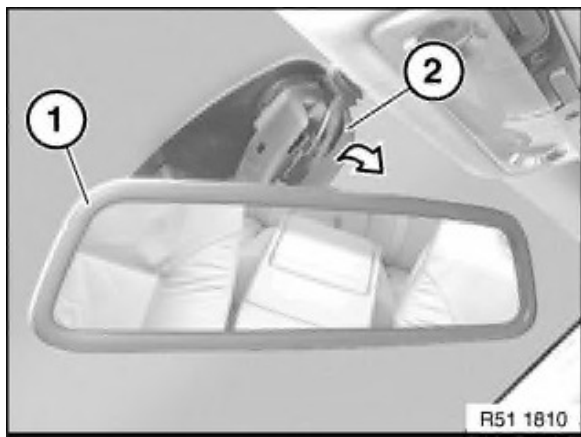

Twist mirror (1) at an angle towards front and left/top.  
Swivel right end cap (2) off ball neck in direction of arrow; this detaches the engagement clip from the metal foot.

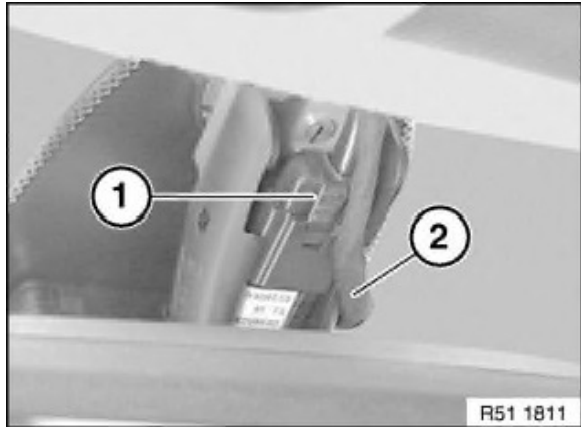

Disconnect plug connection (1).  
Pay attention to cable guide (2) for rain sensor.

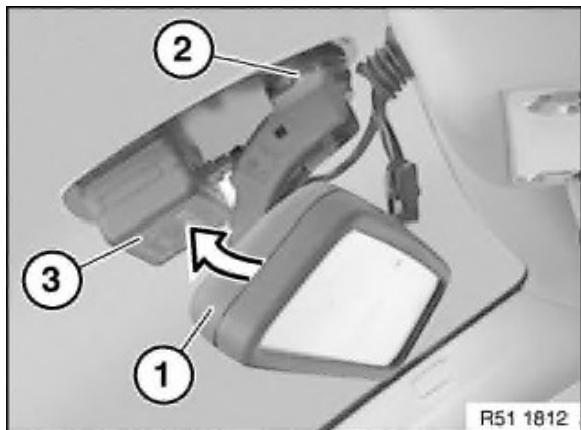

**Important!**

Do not remove interior mirror (1) towards rear or by twisting (risk of damage).

When snapping out, do not damage control unit (3) for rain sensor.

Snap out interior mirror (1) from mirror mount (2) towards front by striking with ball of thumb and remove.

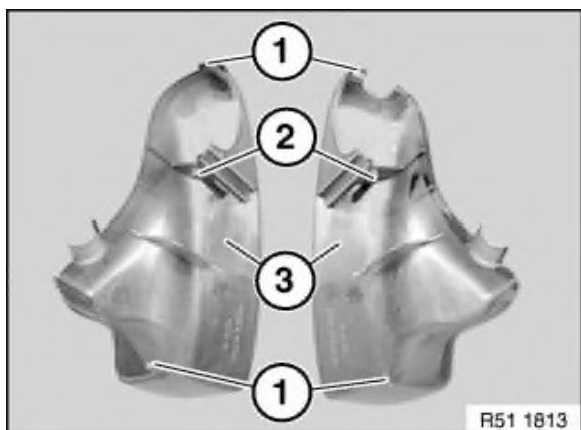

*Installation:*

Clips (1) and retaining hooks (2) of end caps (3) must not be damaged, replace if necessary.

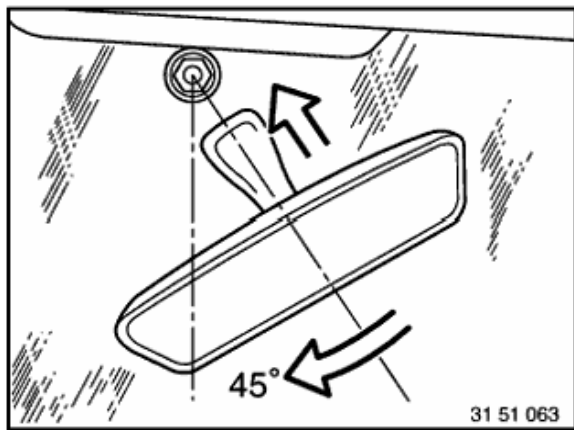

*Installation:*

1. Twist mirror foot by approx. 45° and fit to mirror mount.
2. Turn mirror foot until it engages on mirror base.

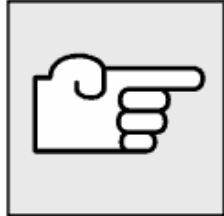

Only replace with version with remote control for central locking:

*Installation:*

Initialize all transmitters (ignition keys), refer to Owner's Handbook.