

**Note:**

With the E 38, BMW offers a choice of normal mirror glass or mirror glass with automatic dip action (electro-chrome technology). The removal procedure differs from one type of mirror to another (risk of damage).

Mirror without automatic dip action:

The mirror glass does not have a plastic frame.

**Important!**

Make sure car has room temperature to prevent the clips from breaking off.

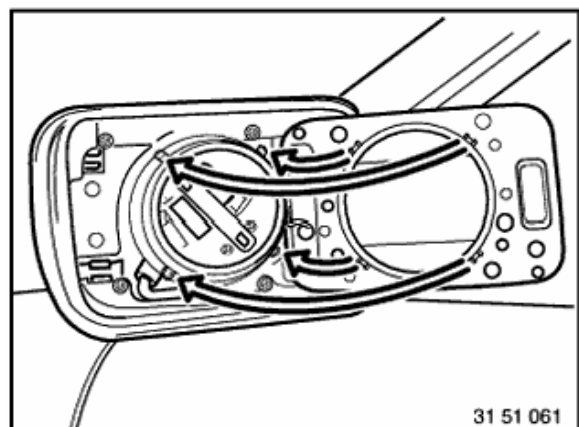
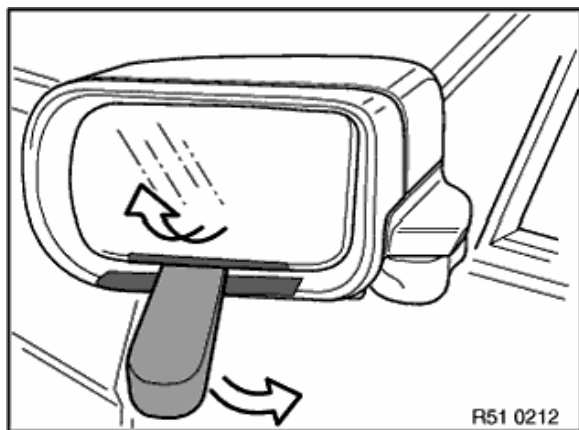
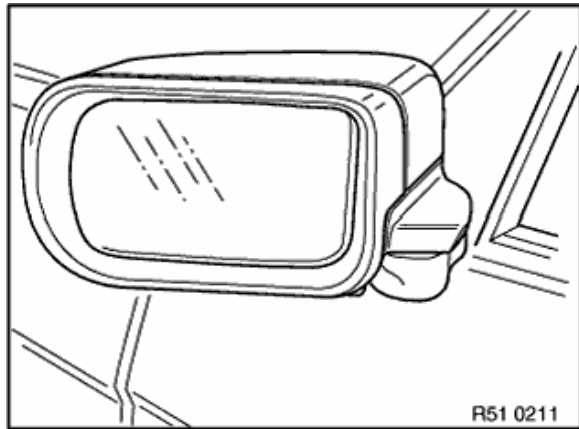

Tilt mirror glass.

Remove cement between mirror glass and edge of housing (risk of damage).

Unclip mirror glass using a wooden wedge.

If applicable, remove connector (mirror glass heating) and remove mirror glass.

**Installation:**

Install mirror glass that clips are seated on tabs and clip on glass. Ensure correct engagement.

Check function.

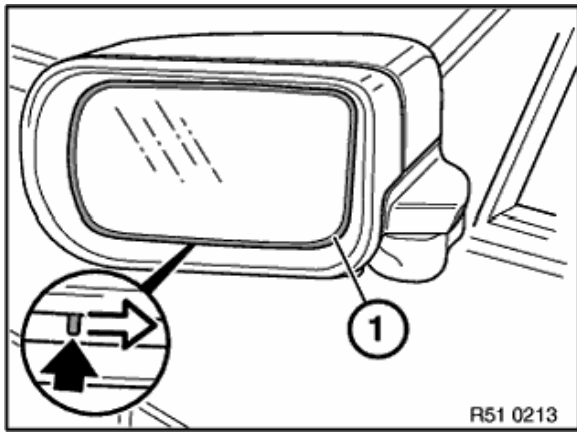

Mirror with automatic dip action:

Slide journal to right (bayonet connection) and carefully lift off mirror glass (1).

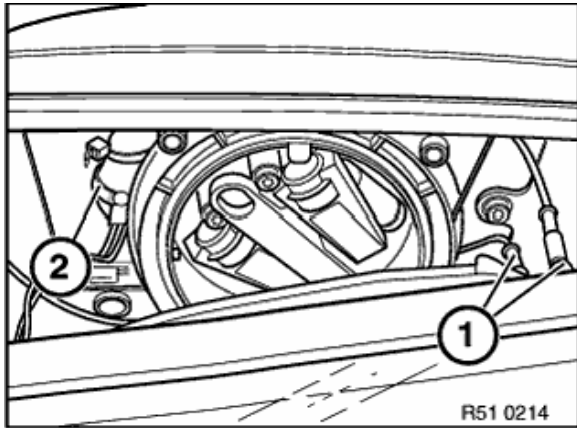

If applicable, remove connector (1) (mirror glass heating).

Unlock connector (2) (only 1 detent hook at front) and pull downwards to remove.

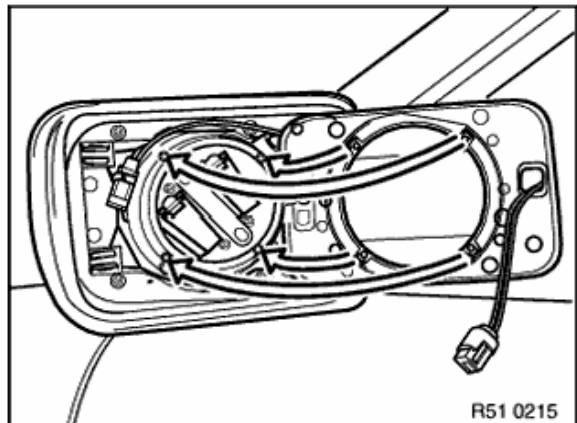

**Installation:**

Place mirror glass with apertures over lugs.

Slide pin to left until pin is perpendicular.

Check function.