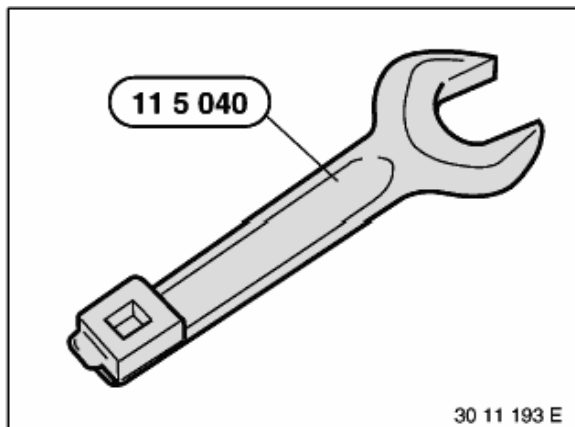
**Caution!**

Left-hand threads.

Using special tool 11 5 050 brace against pulley and unfasten cap nut from water pump using special tool 11 5 040.

Remove fan wheel with fan coupling from water pump.

**Installation:**

Tighten down fan wheel using special tool 11 5 040.

Tightening torque,
refer to Technical Data 11 52 1AZ

Note:

When using special tool 11 5 040, 30 Nm on the torque wrench scale are equivalent to a tightening torque of 40 Nm.

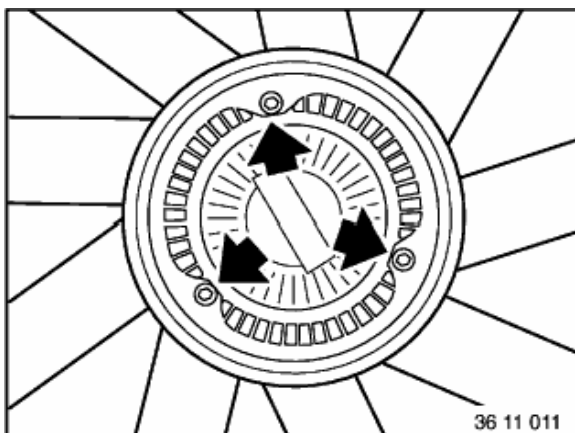

Unfasten screws and detach fan from fan coupling.