

Table of Contents

Cooling Systems

Subject	Page
Introduction	5
Cooling System N54	5
Layout	7
Radiator	7
Electric Coolant Pump (EWP)	8
Cooling System N55	10
Engine Cooling Circuit Diagram (N55)	14
Cooling System N63	16
Coolant Pumps N63	18
Main coolant pump	18
Auxiliary coolant pump for turbocharger cooling	18
System Protection	18
Cooling System N74	19
Coolant Pumps N74	20
Main coolant pump	20
Auxiliary water pump for exhaust turbochargers	20
Expansion Tank	21
 Charge Air Cooling	 23
Charge Air Cooling N63	23
Intercoolers	24
Electric Coolant Pump	24
Venting	24
Charge Air Cooling N74	24
Auxiliary Coolant Pump for Charge Air Cooling	24
Charge-air Cooler	24
 Engine Oil Cooling	 27
Engine Oil Cooling (N54)	27
Oil Pump and Pressure Control (N55)	28
Oil Pressure	31
Oil Pressure Sensor	31
Electronic Oil Condition Monitoring	31
Function of the Oil Condition Sensor	33
Faults/Evaluation	33

Subject	Page
Electronic Oil Level Indicator34
Static Oil Level Measurement at Engine OFF34
Dynamic Oil Level Measurement During Vehicle Operation36
Display Options37
Heat Management39
Intelligent Heat Management Options41
System Protection42
Measures and Displays for Engine Oil Temperature42
Measures and Displays for Coolant Temperature43

**BLANK
PAGE**

Cooling Systems

Model: All

Production: All

OBJECTIVES

After completion of this module you will be able to:

- Understand the operation of the main components in the cooling system
- Understand the different charge air cooling systems
- Understand the principles of Heat Management
- Understand the difference between static and dynamic oil measurement
- List the advantages of EWP

Introduction

Cooling System N54

The cooling system of the **N54** engine consists of a radiator circuit and an isolated oil cooling circuit. The fact that there is an isolated oil-cooling circuit ensures that heat is not introduced via the engine oil into the engine's coolant system.

There is a significantly greater quantity of heat on account of this engine's increased power of 75.5 kW/l in comparison with the N52.

This boundary condition is satisfied by the engine cooling system with its increased performance. This increase in power was to be realized in spite of some factors less advantageous to cooling.

Factors to be mentioned here are:

- Approximately 15% less flow area is available on account of the intercooler located below the radiator.
- The already small amount of space provided by the engine compartment is further limited by the accommodation of further components.
- Because the exhaust turbochargers are cooled by the coolant, an additional quantity of heat is introduced into the system via these turbochargers.

Measures for increasing cooling-system performance:

- Coolant pump with increased power 400 W/9000 l/h
- Separation of water and engine-oil cooling
- Radiator with increased power
- Electric fan with increased power 600W for all gearbox variants

Charge-air cooling is described in the section dealing with air-intake ducting.

Index	Explanation	Index	Explanation
1	Radiator	9	Heat exchanger
2	Gear-box oil cooler	10	Outlet temperature sensor, cylinder head
3	Outlet temperature sensor	11	Thermostat, engine oil cooler
4	Engine oil cooler	12	Coolant expansion tank
5	Thermostat for gearbox oil cooler	13	Vent line
6	Map thermostat	14	Gearbox oil cooler
7	Electric coolant pump	15	Fan
8	Exhaust turbocharger		

Layout

The structure of the coolant circuit on the **N54** is the same as that of the N52 engine. The engine is flushed through with coolant in accordance with the cross-flow concept. Cooling output can be influenced as a function of load by activating the following components:

- Electric fan
- Electric coolant pump
- Map thermostat

It is also possible in an N54 engine in conjunction with an automatic gearbox to utilize the lower area of the radiator to cool the gearbox by means of the gearbox-oil cooler. This is achieved as in the N52 engine with control sleeves, which are introduced into the radiator tank.

Radiator

Design measures have been used to increase the performance of the radiator itself. The performance of a radiator is dependent on its radiation surface. However, the intercooler still had to be installed underneath the radiator, and this meant that it was necessary to compensate for the smaller flow area available.

Compared with the N52 engine, the radiator used in the N54 engine has a block depth which has been increased to 32 mm. In addition, the water pipes are situated closer together than in previously used radiators. The upshot of this is an increase in the utilizable radiation surface.

Electric Coolant Pump (EWP)

The coolant pump of the **N54** engine is an electrically driven centrifugal pump with a power output of 400W and a maximum flow rate of 9000 l/h. This represents a significant increase in power of the electric coolant pump used in the N52 engine, which has a power output of 200 W and a maximum flow rate of 7000 l/h.

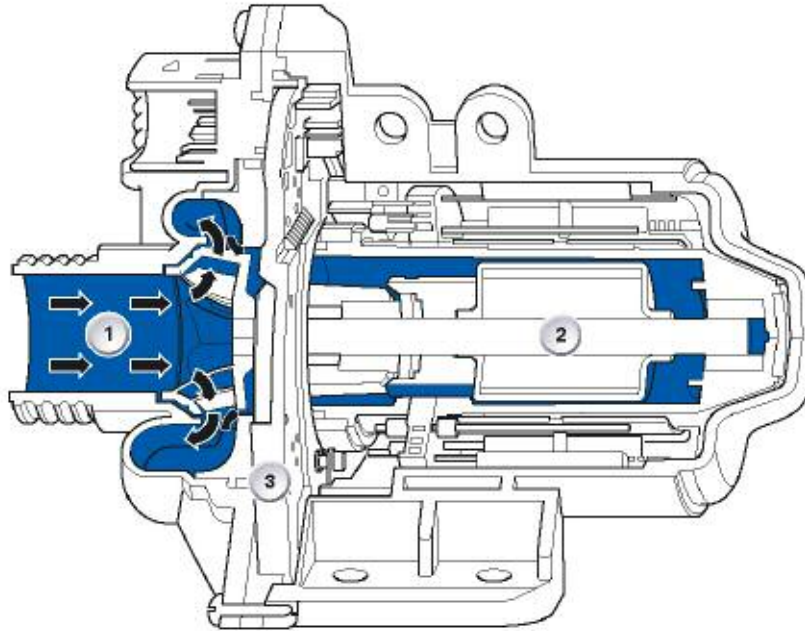

Index	Explanation	Index	Explanation
1	Pump	3	Electronics for coolant pump
2	Motor		

The power of the electric wet-rotor motor is electronically controlled by the electronic module (3) in the pump. The electronic module is connected via the **bit-serial data interface** (BSD) to the ECM engine control unit.

The engine control unit uses the engine load, the operating mode and the data from the temperature sensors to calculate the required cooling output. Based on this data, the engine control unit issues the corresponding command to the electric coolant pump.

The electric coolant pump regulates its speed in accordance with this command.

The system coolant flows through the motor of the coolant pump, thus cooling both the motor as well as the electronic module. The coolant lubricates the bearings of the electric coolant pump.



The same rules apply to all Electric Coolant Pumps (EWP). The pump must be filled with coolant when removed for service to prevent any corrosion. Also, the pump impeller must be turned by hand before installation to ensure the pump is not seized.



Particular care must be taken when performing servicing work to ensure that the pump does not run dry. When the pump is removed, it should be stored filled with coolant. The bearing points of the pump could stick fast if the pump were not filled with coolant. This could jeopardize subsequent start-up of the pump thus rendering the entire heat management system inoperative (**the pump not starting up could cause serious engine damage**). If the pump should ever run dry, the pump wheel should be turned by hand before finally connecting the coolant hoses. The system should then be immediately filled with coolant.



Particular care must be taken during assembly to ensure that the connector is clean and dry and the connections are undamaged.

Diagnosis should be performed only with the approved adapter cables. The information provided in the repair instructions must be observed.



Due to this coolant pump, a special filling and **bleeding procedure** must be implemented for servicing:

1. Fill system with coolant via the expansion tank (AGB).
Top up coolant level to lower edge of expansion tank.
2. Close expansion tank.
3. Switch on ignition.
4. Set heating to maximum (temperature), switch on blower (lowest stage).
5. Press accelerator pedal module right down for at least 10 seconds. The engine must NOT be started.
6. Bleeding via EWP takes approx. 12 minutes. Then check coolant level in expansion tank, top up to MAX marking if necessary.
7. Check cooling circuit and drain plugs for leaks.
8. If the procedure needs to be repeated several times, allow DME to completely de-energize (remove ignition key for approx. 3 minutes) and then repeat procedure as from Point 3.

Connect battery charger if battery charge level is low.

Cooling System N55

The cooling system of the **N55** is enhanced with additional oil cooling.

Two different types of oil cooling systems are used depending on the model and application. In the “hot climate” version, heat transfer from the engine oil to the engine coolant is avoided by separating the oil cooler from the engine coolant circuit. The other version uses an auxiliary radiator in combination with an oil to coolant heat exchanger bolted to the oil filter housing. The auxiliary radiator enhances cooling efficiency by adding surface area to the cooling system.

N55 Cooling System

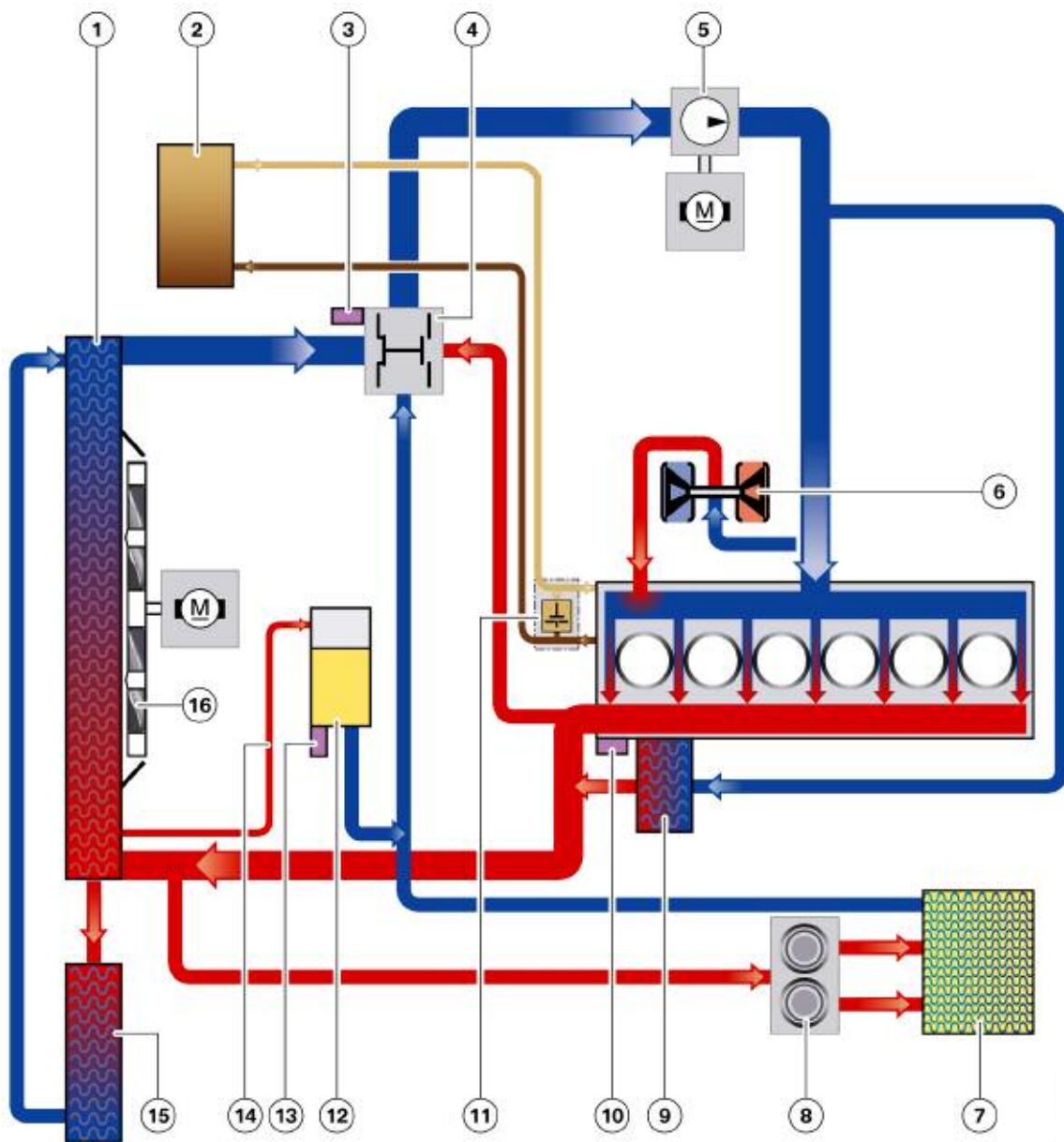

Index	Explanation
1	Radiator
2	Engine oil to air cooler (hot climate version)
3	Heater coil
4	Characteristic map thermostat
5	Electric coolant pump
6	Exhaust turbocharger
7	Heating heat exchanger
8	Coolant valve
9	Oil-to-coolant heat exchanger
10	Coolant temperature sensor
11	Engine oil thermostat (hot climate version)
12	Expansion tank
13	Coolant level switch
14	Equalization line
15	Auxiliary radiator
16	Electric fan

N55 Cooling System

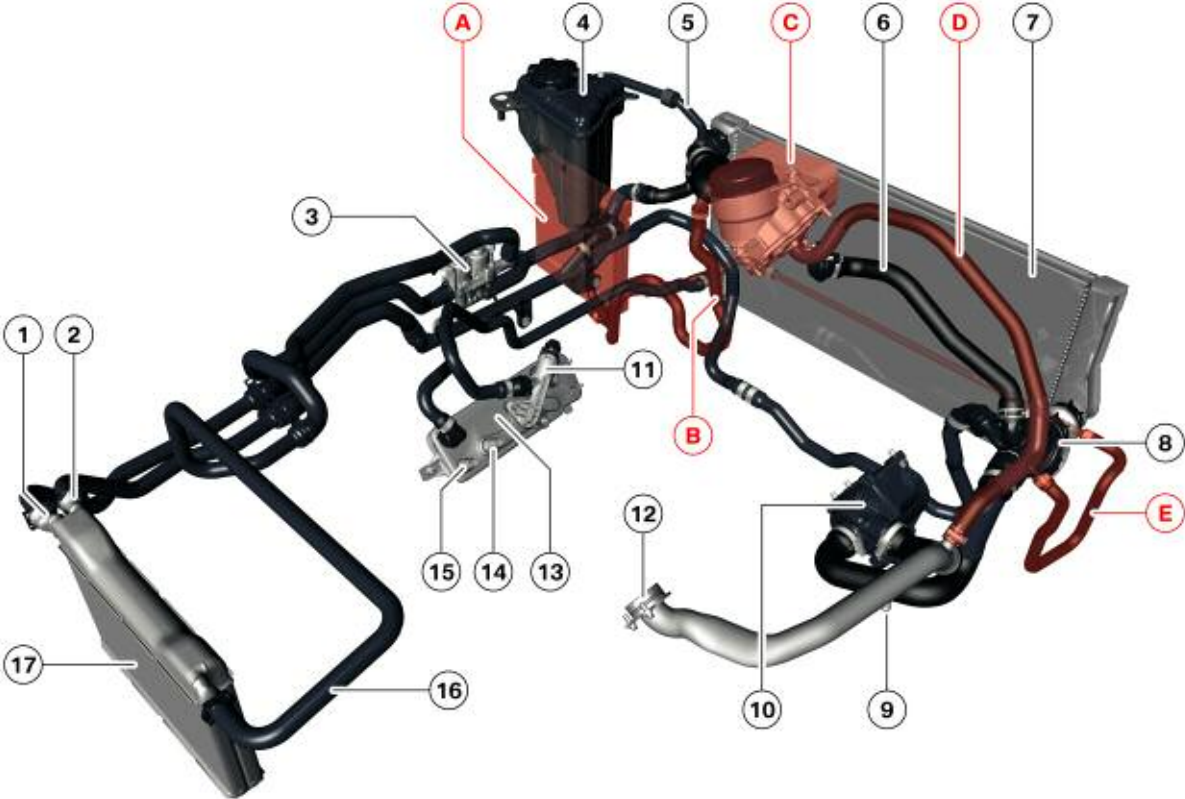

Index	Explanation	Index	Explanation
A	Auxiliary radiator	7	Bypass line for small cooling circuit
B	Coolant feed line to auxiliary radiator	8	Thermostat
C	Oil-to-coolant heat exchanger	9	Electric coolant pump
D	Coolant feed line to oil-to-coolant heat exchanger	10	Exhaust turbocharger supply line
E	Coolant return line from auxiliary radiator	11	Thermostat for transmission oil cooling
1	Zone 1 feed line, heating heat exchanger	12	Coolant feed line to engine block
2	Zone 2 feed line, heating heat exchanger	14	Transmission oil-to-coolant heat exchanger
3	Coolant valve	15	Connection, transmission oil line
4	Expansion tank	16	Connection, transmission oil line
5	Equalization line	17	Return, heating heat exchanger
6	Radiator		

The following graphic shows the connection of the auxiliary radiator to the cooling system. The auxiliary radiator is connected to the radiator by means of parallel coolant lines, thus increasing the cooling surface area. This system is combined with an **oil-to-coolant heat exchanger** mounted on the oil filter housing. (See component “C” in page 12.)

N55 Auxiliary Radiator

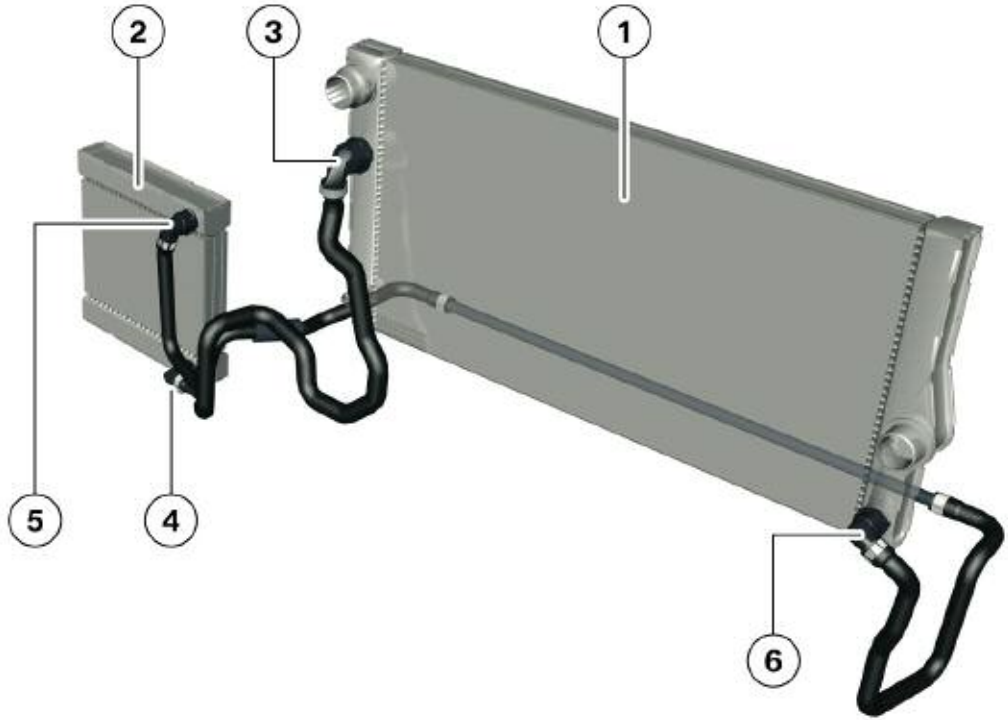

Index	Explanation
1	Radiator
2	Auxiliary Radiator
3	Feed connection to the auxiliary radiator
4	Feed connection at the auxiliary radiator
5	Return connection to the auxiliary radiator
6	Return connection from the auxiliary radiator



If a separate oil to air cooler is not installed, an auxiliary radiator in conjunction with an oil to coolant heat exchanger is used to cool the engine oil.

Engine Cooling Circuit Diagram (N55)

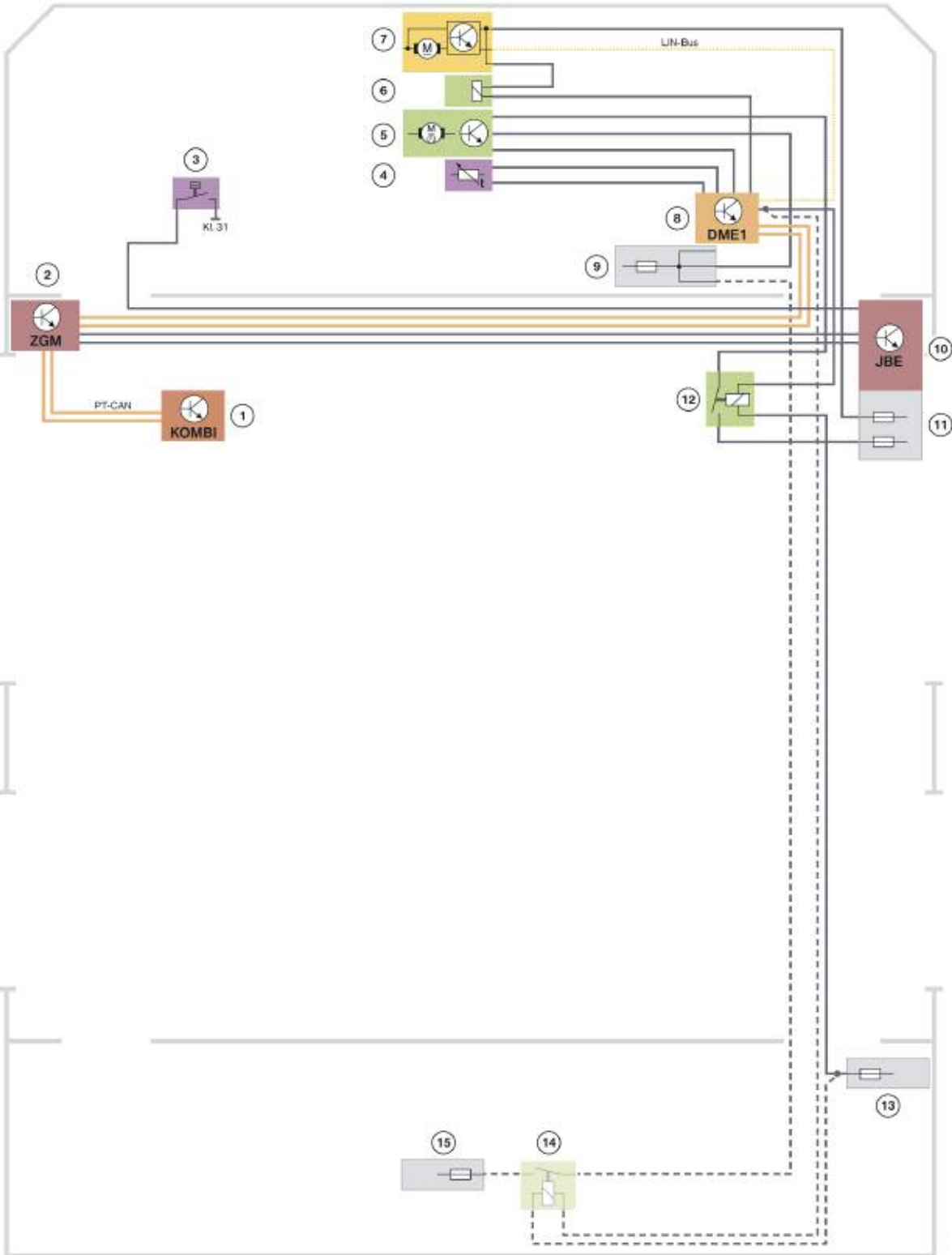

Index	Explanation
1	Instrument cluster
2	Central Gateway Module
3	Coolant level switch
4	Coolant temperature sensor
5	Electric fan
6	Mechanical air flap control
7	Electric air flap control
8	Digital Motor Electronics
9	Front power distribution box
10	Junction box electronics
11	Junction box
12	Electric fan relay
14	Rear power distribution box
15	Electric fan relay (only for 850 Watt and 1000 Watt electric fan)

Cooling System N63

Due to the exhaust turbocharging system and the compact arrangement of the turbochargers in the V-space, the heat output of the **N63** engine is very high. Correspondingly, great significance is attached to the cooling system. In addition, an indirect charge air cooling system has been developed for the first time where the charge air is cooled by an air-to-coolant heat exchanger. There are two separate cooling circuits for engine and charge air cooling.

N63 Cooling System

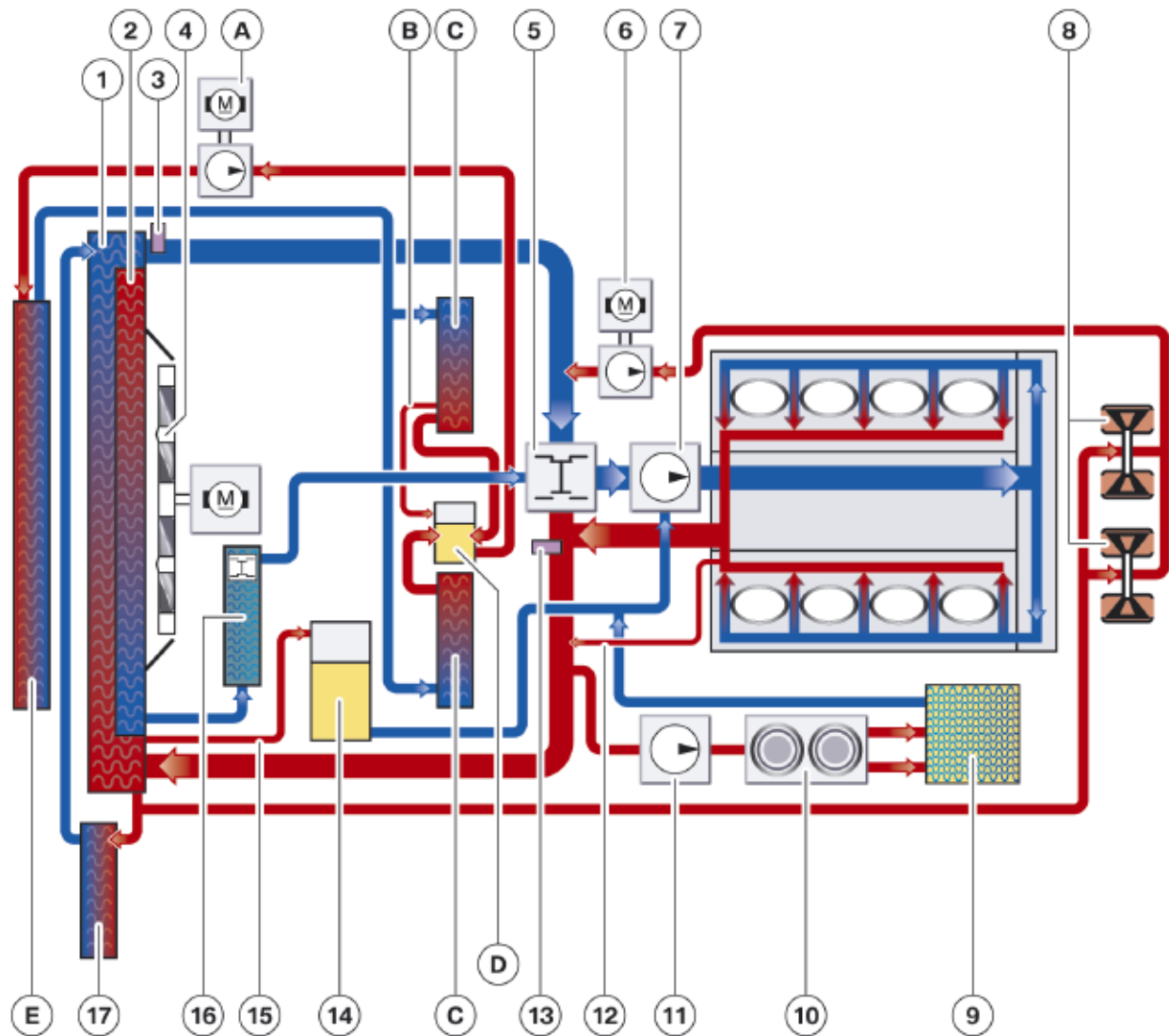

Index	Explanation	Index	Explanation
1	Radiator	12	Vent line
2	Radiator for transmission cooling	13	Coolant temperature sensor at engine outlet
3	Coolant temperature sensor at radiator outlet	14	Expansion tank
4	Electric fan	15	Vent line
5	Characteristic map thermostat	16	Transmission fluid-to-coolant heat exchanger
6	Electric auxiliary coolant pump for turbocharger cooling	17	Auxiliary coolant radiator
7	Coolant pump	A	Electric coolant pump for charge air cooling
8	Exhaust turbocharger	B	Vent line
9	Heating heat exchanger	C	Intercooler
10	Duo-valve	D	Expansion tank for charge air cooling
11	Electric auxiliary coolant pump for vehicle heating	E	Radiator for charge air cooling

The engine cooling system undertakes the classic task of carrying heat away from the engine and maintaining a defined operating temperature as constant as possible. As on the N54 engine, the two turbochargers are also cooled.

Coolant Pumps N63

■ Main coolant pump

The **N63** engine features a conventional coolant pump that is driven by the belt drive. This pump cannot be used to continue cooling the turbochargers after the engine has been shut down. For this reason the N63 is also equipped with an auxiliary coolant pump.

■ Auxiliary coolant pump for turbocharger cooling

The electric coolant pump on the N54 engine features an after-running function to carry away the heat build-up from the turbochargers after the engine has been shut down.

For this function, the **N63** engine is equipped with an additional electrically operated coolant pump with an output of 20 W. This pump is also used during engine operation to assist turbocharger cooling.

The auxiliary electric coolant pump cuts in, taking the following factors into consideration:

- Coolant temperature at engine outlet
- Engine oil temperature
- Injected fuel quantity

The heat input into the engine is calculated based on the injected fuel quantity. This function is similar to the heat management function on 6-cylinder engines.

The after-running period of the auxiliary electric coolant pump can extend up to 30 minutes. The electric fan also cuts in to improve the cooling effect.



As in previous systems, the electric fan runs for a maximum of 11 minutes, however, it now operates more frequently.

System Protection

As on the N54 engine, the **N63** in the event of the coolant or engine oil being subject to excessive temperatures, certain functions in the vehicle are influenced in such a way that more energy is made available to the engine cooling system, i.e. temperature increasing loads are avoided.

Cooling System N74

Because of the turbocharging and indirect charge air cooling, the **N74** engine has the same cooling requirements as the N63 engine. Consequently it too has two separate cooling circuits. One is for cooling the engine and exhaust turbochargers, the other is for charge air cooling and for cooling the two engine control units.

The engine cooling system performs the task of drawing heat off the engine and maintaining the operating temperature as constant as possible. As on the N54 and N63 engines, the two exhaust turbochargers are also cooled.

On the N74 engine, the coolant passages have been integrated mainly in the engine block. Optimizations to the engine cooling circuit have enabled a significant reduction in the coolant quantity for the bypass mode, thus shortening the warm-up phase.

The coolant feed line downstream of the coolant pump is routed directly beside the engine's main oil duct. The oil in the main oil duct flows in the opposite direction to the coolant. This enhances the heat exchange between the two media, and has a positive effect on the engine oil temperature. The overall cooling effect is comparable with that of an engine oil-coolant heat exchanger.

The coolant passages in the cylinder heads are similar to the N63 engine. The coolant flows through the cylinder heads diagonally from the outside to the inside, whereby it flows in at the rear (outside) and flows out at the front (inside). This is also known as diagonal cooling.



As on the N63 engine, an additional electric coolant pump is used which supplies the bearings of the exhaust turbochargers with coolant.

N74 Cooling System

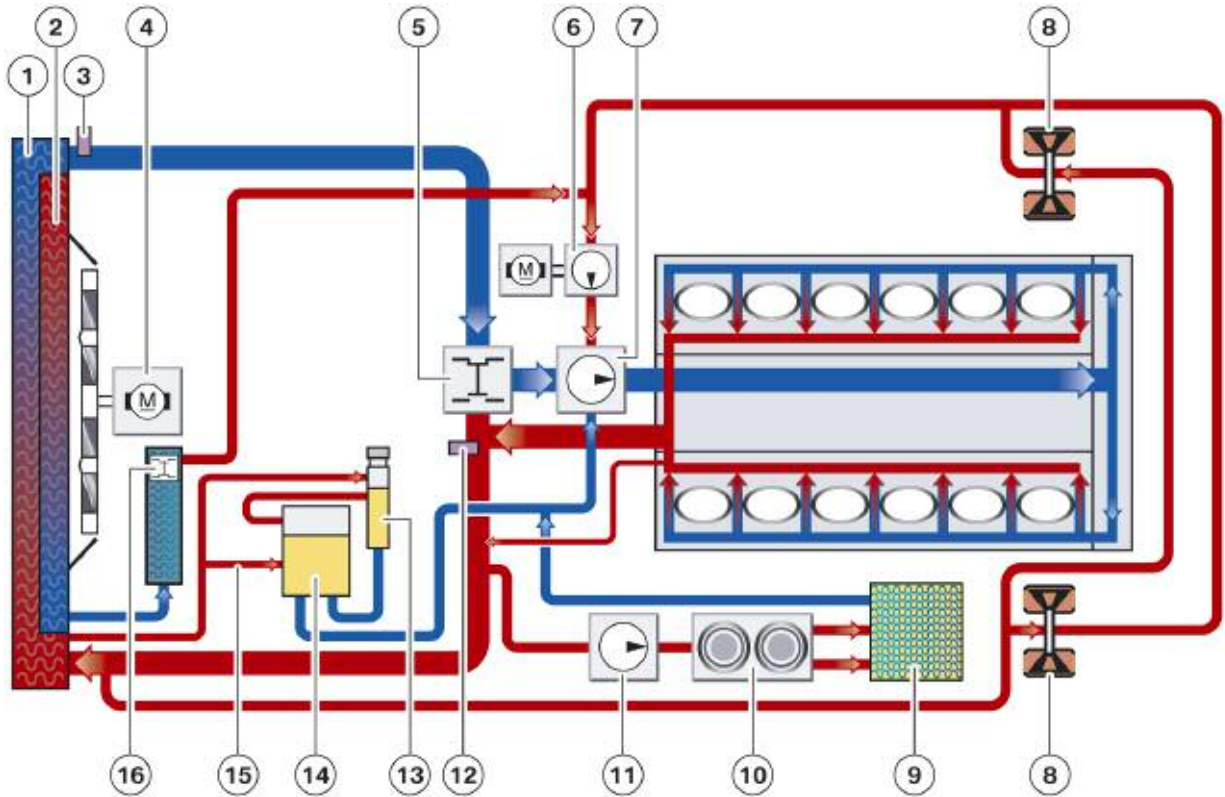

Coolant Pumps N74

■ Main coolant pump

The main coolant pump is a conventional coolant pump driven mechanically by the belt drive.

■ Auxiliary water pump for exhaust turbochargers

Like the N63 engine, the N74 engine has an electric auxiliary water pump which allows heat to be dissipated from the exhaust turbochargers even after the engine has been switched off. This coolant pump has an electrical power output of 20 W. It is also used during engine operation to support exhaust turbocharger cooling. The electric auxiliary coolant pump is activated based on the following factors:

- Coolant temperature at the engine outlet
- Engine oil temperature
- Injected volume of fuel

Index	Explanation
1	Radiator
2	Radiator for transmission cooling
3	Coolant temperature sensor at radiator outlet
4	Electric cooling fan
5	Characteristic map thermostat
6	Electric auxiliary coolant pump for turbocharger cooling
7	Coolant pump (mechanical)
8	Exhaust turbocharger
9	Heater core
10	Duo Heater valve
11	Electric auxiliary coolant pump for vehicle heating
12	Coolant temperature sensor at engine outlet
13	Filling canister
14	Expansion tank
15	Vent line
16	Transmission fluid thermostat and the fluid-to-coolant heat exchanger

The injected volume of fuel is used to calculate the heat contribution to the engine. Operation is similar to that of the heat management system on the 6-cylinder engines. The after-running period of the electrical auxiliary coolant pump can last up to 30 minutes.



To improve the cooling effect, the electric fan is also switched on. As in previous systems, the electric fan runs for a maximum of 11 minutes, however, it now operates more frequently.

Expansion Tank

For space reasons, the expansion tank is located in the front fender behind the wheel arch. A separate filling canister bolted to the front of the engine enables filling. The expansion tank and filling canister are interconnected by an expansion and tank ventilation line.

NOTES

PAGE

Charge Air Cooling

Charge Air Cooling N63

With the introduction of the **N63** engine, indirect charge air cooling is used for the first time at BMW. Heat is taken from the charge air by means of an air-to-coolant heat exchanger. This heat is then given off via a coolant-to-air heat exchanger into the ambient air. For this purpose, the charge air cooling system has its own low temperature cooling circuit, which is independent of the engine cooling circuit.

N63 Charge Air Cooling System

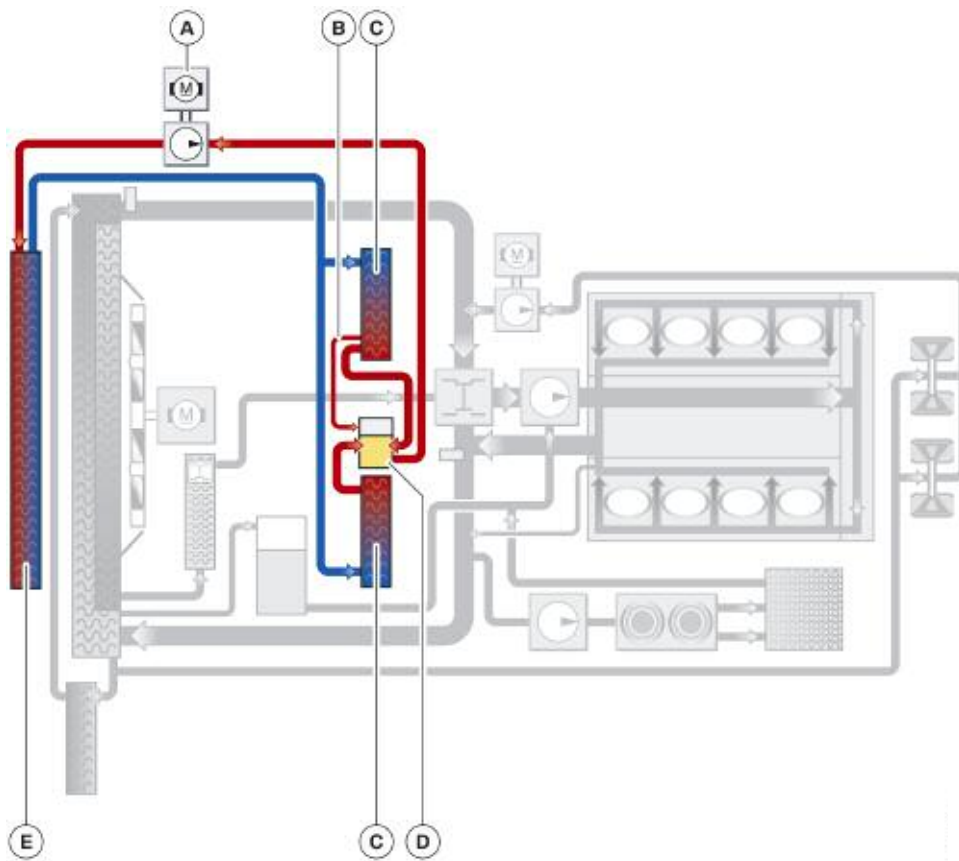

Index	Explanation	Index	Explanation
A	Electric coolant pump for charge air cooling	D	Expansion tank for charge air cooling
B	Vent line	E	Radiator for charge air cooling
C	Intercooler		

Intercoolers

The intercoolers are installed on the end faces of the cylinder heads. They operate in accordance with the counterflow principle and cool the charge air by up to 80°C.

Electric Coolant Pump

The coolant circuit for charge air coolant is operated with a 50 W pump. This pump does not run automatically when the engine is turned on.

Pump actuation depends on the following values:

- Outside temperature
- Difference between charge air temperature and outside temperature

Venting

A separate venting routine is provided for the purpose of venting the low-temperature circuit of the charge air cooling system. This venting is initiated in the same way as for the cooling circuit on 6-cylinder engines.

The venting test module can be found in the “Service Functions” section of the diagnostic program.

Charge Air Cooling N74

The N63 engine was the first BMW engine to use indirect charge air cooling; this has now also been adopted for the **N74** engine. The heat is extracted from the charge air by means of an air to coolant heat exchanger. This heat is then released to the ambient air across a coolant to air heat exchanger. To achieve this, the charge air cooling has its own low-temperature cooling circuit. This is independent of the engine cooling circuit.

Auxiliary Coolant Pump for Charge Air Cooling

The cooling circuit for charge air cooling is operated with a 50 W pump. It does not run automatically when the engine is switched on.

The following parameters are used for the auxiliary pump activation:

- Outside temperature
- Difference between charge-air temperature and outside temperature.

Charge-air Cooler

The charge air coolers (intercoolers) are attached to the intake system near the rear of the cylinder heads. They enable efficient cooling of the charge air by extracting heat energy from the air charge and carrying it away to the coolant to air heat exchanger located in the front of the vehicle.

N74 Charge Air Cooling System

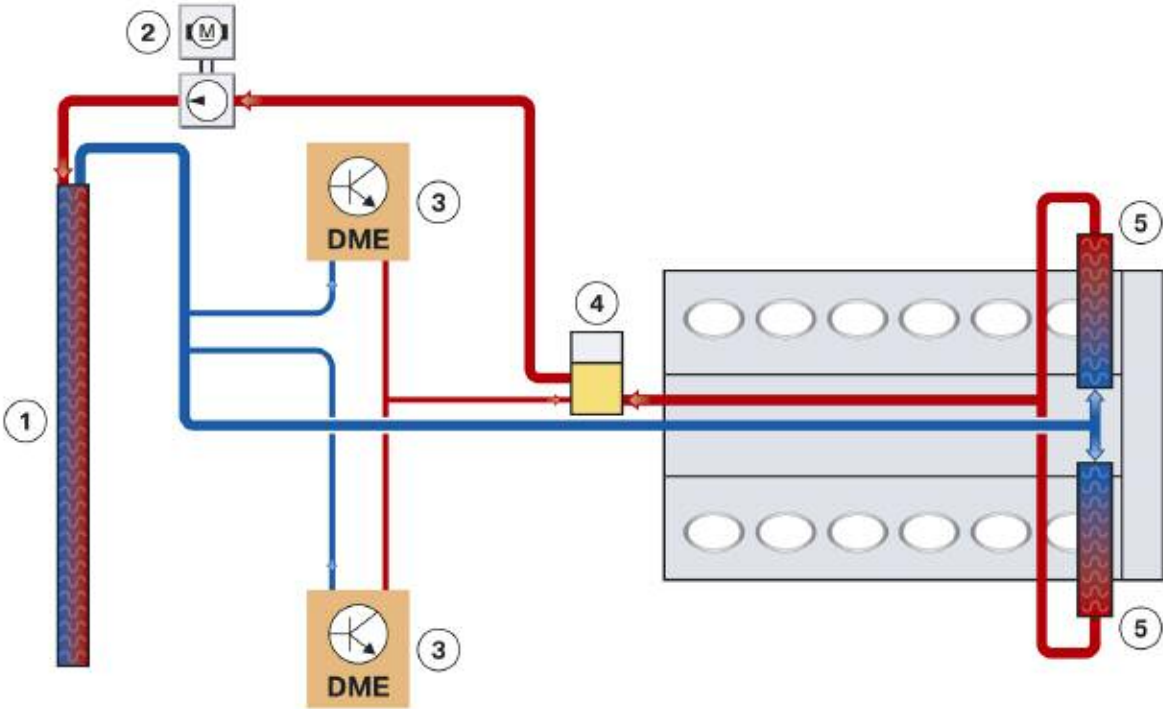

Index	Explanation
1	Radiator for charge air cooling
2	Electric coolant pump for charge air cooling
3	Engine control unit
4	Expansion tank
5	Charge-air cooler

NOTES

PAGE

Engine Oil Cooling

One of the main purposes of the ECM is to monitor and control the Engine-Oil Cooling which includes the actuation of several components. In the following pages you will find a generic explanation on how this system works. For more detailed information please access BMW Training Reference Manuals found on-line.

Engine Oil Cooling (N54)

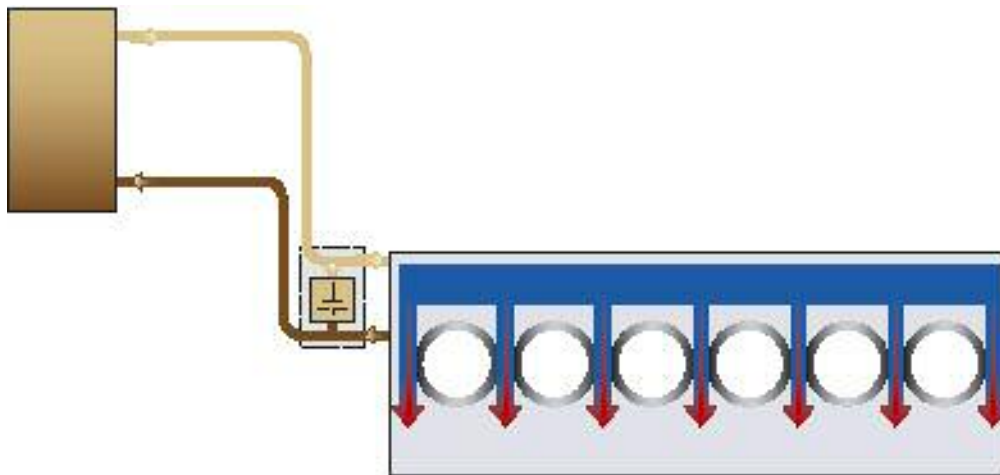

The **N54** engine is equipped with a high performance engine-oil cooler. The pendulum-slide pump delivers the oil from the oil sump to the oil filter. A thermostat flanged to the oil-filter housing admits the oil to the engine-oil cooler. The engine-oil cooler is located in the right wheel arch. The thermostat can reduce the resistance opposing the oil by opening the bypass line between the feed and return lines of the engine-oil cooler. This ensures that the engine warms up safely and quickly.

Oil Pump and Pressure Control (N55)

The oil pump has been redesigned with regard to the functionality and durability of the Duroplast reciprocating slide valve. The oil pump used in the **N55** engine is a further development of the shuttle slide valve volume control oil pump. The activation of the oil pump is adapted by the engine management and controlled through an oil pressure control valve.

The delivered oil volume is controlled by means of the oil pressure, based on specific requirements. The modifications, compared to previous pumps, are primarily in the pump activation system. The oil pressure no longer acts directly on the control piston but rather directly on the slide valve. The engine management activates the electrohydraulic pressure control valve, which affects the oil pressure at the slide valve control mechanism within the oil pump, altering the pump output. This has the advantage of avoiding power losses by running the oil pump only when needed.

The electrohydraulic pressure control valve controls the pump output and is bolted to the front of the engine block. It is operated based on a characteristic map within the DME (ECM) which in turn is based on feedback from the oil pressure sensor. The N55 uses a special oil pressure sensor for this purpose which functions in the similar way as the HPI fuel pressure sensor.

Characteristic map-controlled oil pressure (N55)

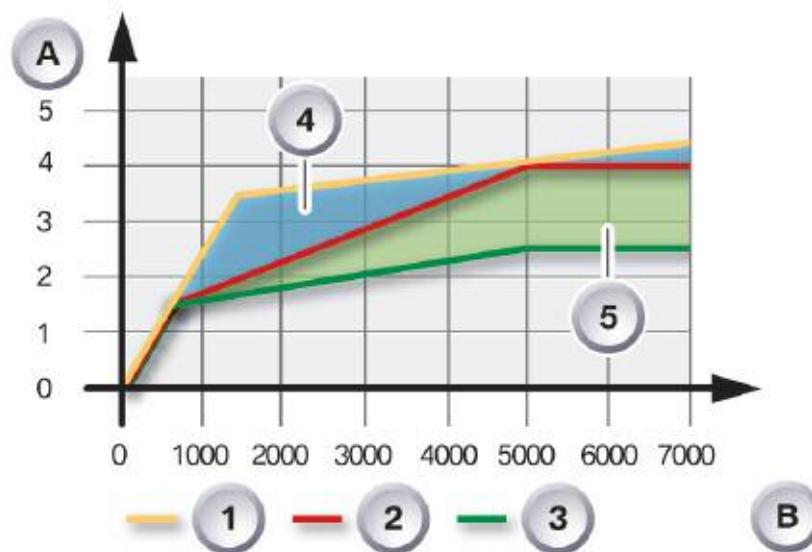

Index	Explanation	Index	Explanation
A	Oil pressure (bar)	3	Characteristic map-controlled oil pressure, no load
B	Engine speed (rpm)	4	Saving potential, full load
1	Oil pressure control, hydraulic/ mechanical	5	Saving potential, no load
2	Characteristic map-controlled oil pressure, full load		

The oil pressure generated by the oil pump (2) is delivered to the engine's lubricating points and hydraulic actuators. This system uses oil pressure feed back to control the desired operating oil pressure. For this purpose, the oil pressure downstream of the oil filter (7) and engine oil-to-coolant heat exchanger (9) is adjusted by the DME (map-controlled) via the pressure control valve (4) to the pressure control valve (3).

The actual generated oil pressure is registered by the oil pressure sensor (10) and recognized by the engine management.

In the event of an electrical malfunction, the oil pressure is set to the default control setting. The pump compression springs are allowed to expand, moving the slide valve to its maximum oil pressure position.

Hydraulic diagram of the N53 engine oil circuit with electronic pressure control

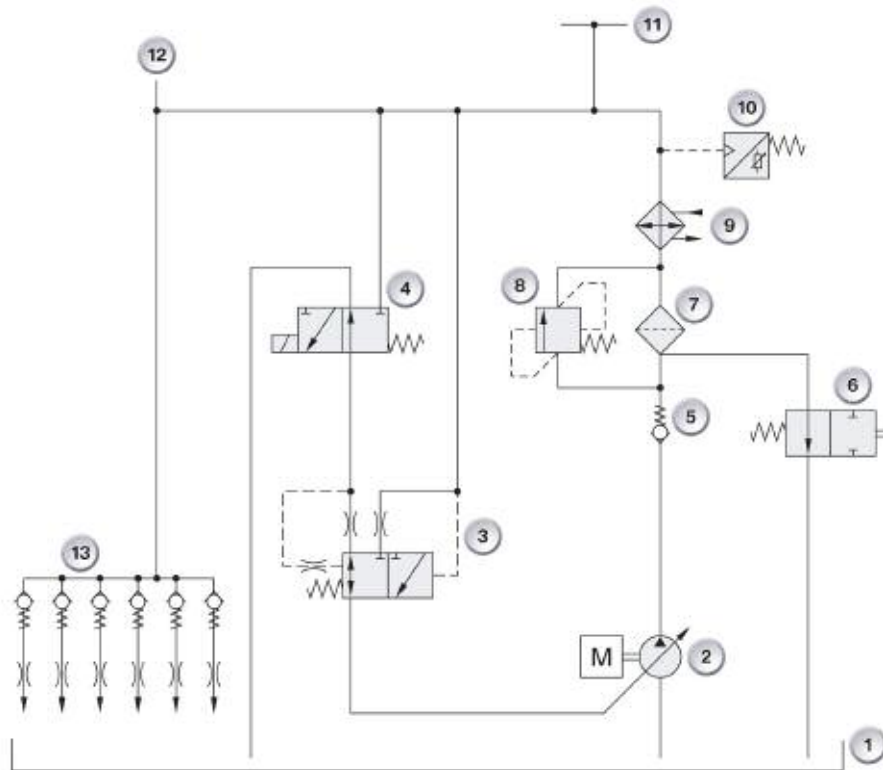

Index	Explanation	Index	Explanation
1	Oil Pan	8	Filter By-pass valve
2	Volume controlled oil pump	9	Engine oil to coolant heat exchanger
3	Pressure regulating valve	10	Oil Pressure sensor
4	Electro-hydraulic pressure regulating valve	11	Lubricating points, cylinder head
5	Non-return valve	12	Lubricating points, engine block
6	Outlet valve at the filter	13	Oil spray nozzles, piston crowns
7	Oil filter		

Note: The N53 hydraulic circuit diagram shown is for explanation of the oil pressure control only, and does not apply directly to the N55 engine.

N55, oil pump and pressure control valve

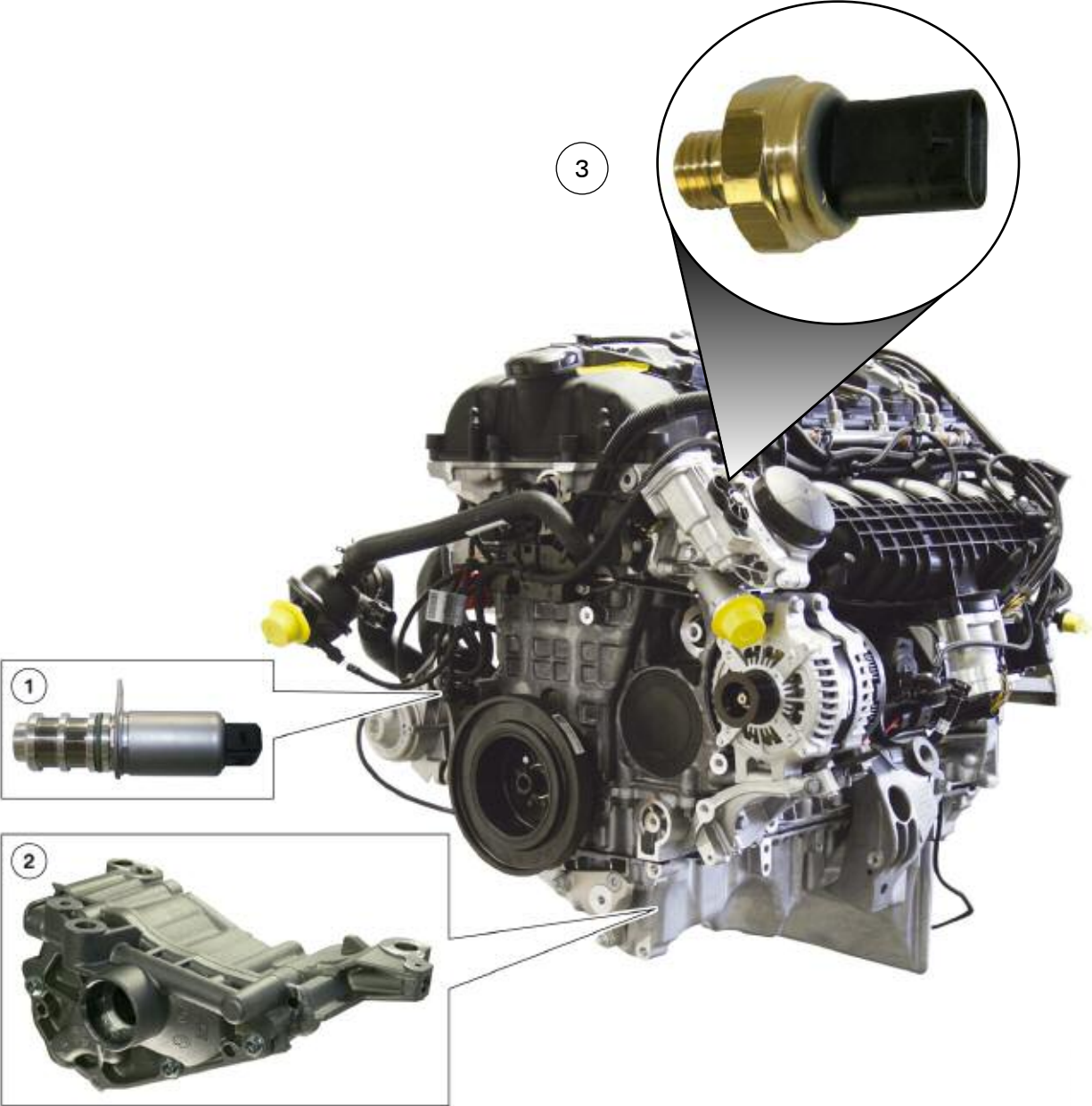

Index	Explanation
1	Oil pressure control valve
2	Oil pump
3	Oil pressure sensor

Oil Pressure

Since the **N55** engine has an oil pump with electronic volumetric flow control, it is necessary to measure the oil pressure precisely. For this reason, a new oil pressure sensor is installed.

Advantages of the new oil pressure sensor:

- It now measures absolute pressure (previous measured relative pressure).
- It is characteristic map control in all speed ranges.

Oil Pressure Sensor

The new oil pressure sensor can now determine the absolute pressure.

The sensor delivers a more accurate pressure reading which is required for the electronic volume control oil pump function.

The sensor design is identical to that of the (high) fuel pressure sensor. The DME supplies a voltage of 5 Volt to the oil pressure sensor.



N55, oil pressure sensor

Electronic Oil Condition Monitoring

The oil quality sensor is used for measuring the oil level as on previous BMW engines. No oil dipstick is used in most BMW NG Engines.

There is no dipstick including the guide tube on most BMW NG engines. This represents a convenience function for the customer while enabling more accurate recording of the engine oil level.

The engine oil level is measured by an oil condition/quality sensor and indicated in the central information display (CID) or KOMBI. The engine oil temperature and the oil condition are also registered or calculated by the oil condition sensor. The signal from the oil condition sensor is evaluated in the ECM. The evaluated signal is then routed via the proper Bus to the instrument cluster and to the CID.

Registering the engine oil level in this way ensures the engine oil level in the engine does not reach critically low levels thus protecting the engine from the associated damage. By registering the oil condition, it is also possible to determine when the next engine oil change is due. Overfilling the engine with oil can cause leaks - a corresponding warning is therefore given.

Oil condition sensor

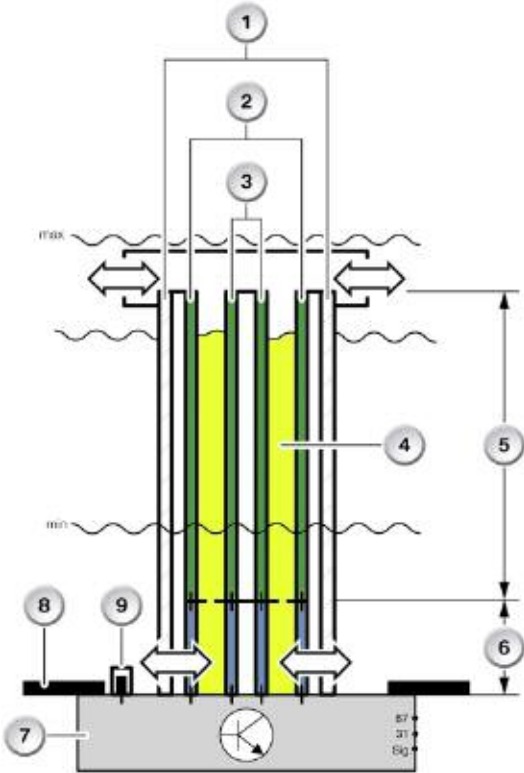

Index	Explanation	Index	Explanation
1	Housing	6	Oil Condition Sensor
2	Outer Metal Tube	7	Sensor Electronics
3	Inner Metal Tube	8	Oil Pan
4	Engine Oil	9	Temperature Sensor
5	Oil Level Sensor		

Function of the Oil Condition Sensor

The sensor consists of two cylindrical capacitors arranged one above the other. The oil condition is determined by the lower, smaller capacitor (6). Two metal tubes (2 + 3), arranged one in the other, serve as the capacitor electrodes. The dielectric is the engine oil (4) between the electrodes. The electrical property of the engine oil changes as the wear or ageing increases and the fuel additives break down.

The capacitance of the capacitor (oil condition sensor) changes in line with the change in the electrical material properties of the engine oil (dielectric). This means that this capacitance value is processed in the evaluation electronics (7) integrated in the sensor to form a digital signal.

The digital sensor signal is transferred to the ECM as an indication of the status of the engine oil. This actual value is used in the ECM to calculate the next oil change service due.

The engine oil level is determined in the upper part of the sensor (5). This part of the sensor is located at the same level as the oil in the oil pan. As the oil level drops (dielectric), the capacitance of the capacitor changes accordingly. The electronic circuitry in the sensor processes this capacitance value to form a digital signal and transfers the signal to the ECM.

A platinum temperature sensor (9) is installed at the base of the oil condition sensor for the purpose of measuring the engine oil temperature.

The engine oil level, engine oil temperature and engine oil condition are registered continuously as long as voltage is applied at terminal KL_15. The oil condition sensor is powered via terminal KL_87.



Faults/Evaluation

The electronic circuitry in the oil condition sensor features a self-diagnosis function. A corresponding error message is sent to the ECM in the event of a fault in the oil condition sensor.

Electronic Oil Level Indicator

The oil level is measured in two stages:

- **Static** oil level measurement while the vehicle is stationary
- **Dynamic** oil level measurement during vehicle operation

Static Oil Level Measurement at Engine OFF



This is only a reference measurement as the oil condition sensor (OZS) is flooded when the engine is turned off and can only detect the minimum oil level. The oil level is measured correctly only when the engine is running (see Dynamic oil level measurement).

After switching on the ignition, the static oil level measurement provides the driver with the opportunity of checking whether there is sufficient engine oil for safely and reliably starting the engine.

1. It is important that the vehicle is parked horizontally otherwise the oil level measurement may be incorrect.
2. Select on-board computer function "Service" -> "Oil level".

If there is sufficient engine oil for safe and reliable engine start, a graphic appears in the CID in the form of an engine with a **green oil sump**.



If the oil level is close to minimum, the graphic appears with a **yellow oil sump** and an oil dipstick that represents the low oil level in yellow.

A top-up request +1 liter additionally appears as a text message. The display will not change if less than 1 liter of oil is topped up. MAX is indicated only after topping up a quantity of 1 liter.

If the oil level drops below minimum, the graphic appears with a **red oil sump** and an oil dipstick that represents the low oil level in red.

A top-up request +1 liter will additionally appear as a text message.

The display will not change if less than 1 liter of oil is topped up. MAX is indicated only after topping up a quantity of 1 liter.

If the oil level is above maximum, the graphic appears with a yellow oil sump and an oil dipstick that represents the high oil level in yellow.

A text message is also displayed for the driver.

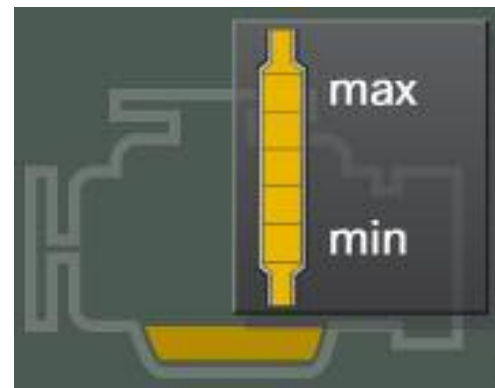
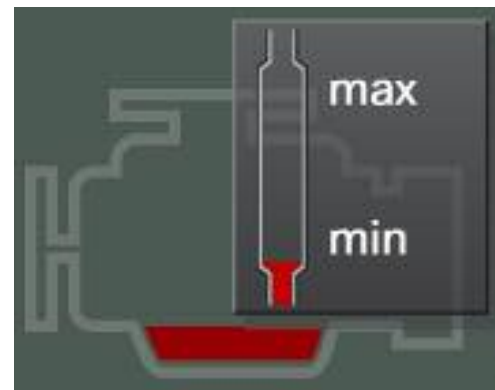
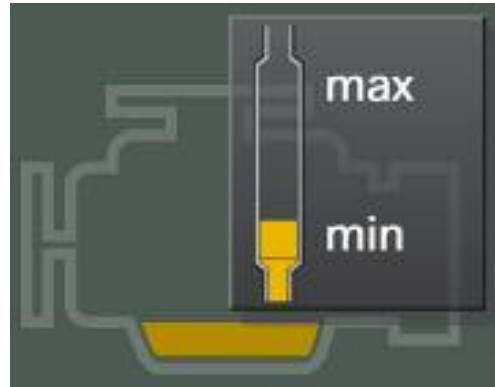

Dynamic Oil Level Measurement During Vehicle Operation



Always perform the dynamic oil level measurement (approx. 5 minutes driving time) after an oil change. The oil level could be misinterpreted as the oil level last stored is initially displayed after an oil change. No oil level is initially stored after replacing or reprogramming the engine control unit. "Oil level below min" is therefore displayed. The correct oil level is indicated after running the engine for approx. 5 minutes.

1. Start engine.
2. Select on-board computer function - "Check oil level".
3. The oil level is measured. A clock symbol may appear while the level measurement is running. The clock symbol appears for up to **50 seconds** after starting the engine when there is no measured value or the long-term value last stored is not within the tolerance range of the currently measured oil level.

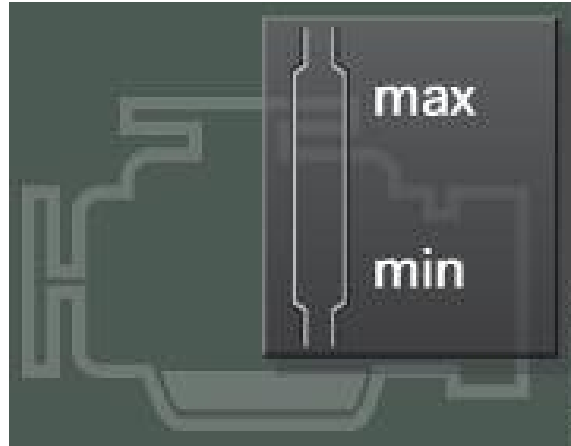

Dynamic oil level measurement begins when following values are reached:

- Engine temperature **> 60°C**
- Engine speed **> 1000 rpm**
- Transverse and longitudinal acceleration **< 4-5 m/s²**.
The transverse acceleration signal is supplied by the DSC. The longitudinal acceleration is calculated from the speed and time factors.
- Increase **< 5%** after covering a distance of approx. 200 m. The increase value is detected by the ambient pressure sensor in the ECM.

On reaching this value, the oil level indicator is updated approx. 5 minutes after starting vehicle operation. The oil level is then continuously measured. The indicator is updated at **20 minute** intervals. The "Check oil level" menu in connection with the dynamic oil level measurement is exited while driving (vehicle speed > 0) approx. 15 seconds after the oil level is displayed.

Display Options

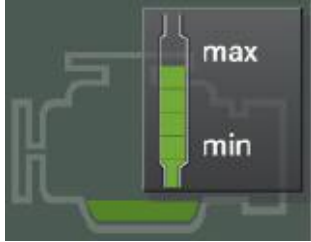
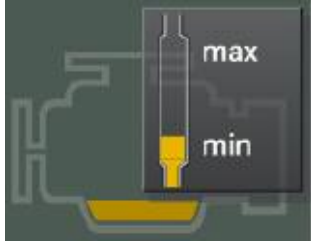
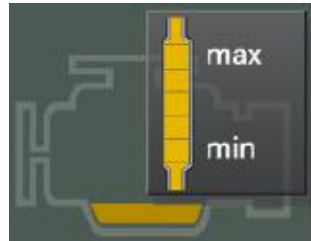
Significance	Remark	Display
Oil OK with engine stationary	The oil level appears in the CID in the form of a graphic together with the "OK" message, indicating that the oil level is in the safe operating range.	
Oil level OK at idle speed	<p>The oil level appears in the CID in the form of a graphic together with the "OK" message, indicating that the oil level is in the safe operating range.</p> <p>A further graphic showing a dipstick appears above the displayed graphic. It shows the oil level in green.</p>	
Oil level too low	The oil level appears in the CID in the form of a graphic together with the request to top up with 1 liter of oil. If the oil is not topped up, this request is repeatedly indicated until the minimum oil level is exceeded.	
Oil level too high	<p>The oil level appears in the CID in the form of a graphic together with the indication that the maximum oil level has been exceeded. The excess engine oil must be extracted in the workshop down to the maximum limit.</p> <p>If no oil is extracted, this request will be repeated until the oil level drops below the maximum limit. This represents an advantage that extends beyond the user friendliness of the monitoring system. Over filling of the engine that can cause leaks is indicated as a warning in the instrument cluster.</p>	
Service	There is a problem with the measurement system if SERVICE appears in the display. In this case, the oil level is forecast from the oil consumption last measured and shown in the display. It is not necessary to immediately visit a workshop. The remaining kilometers are shown in the service menu. In the event of the instrument cluster failing, the oil level can also be read out with the diagnosis tester.	

NOTES

PAGE

Heat Management

The engine control unit of the N54 engine controls the coolant pump according to requirements:

- Low output in connection with low cooling requirements and low outside temperatures
- High output in connection with high cooling requirements and high outside temperatures

The coolant pump may also be completely switched off under certain circumstances, e.g. to allow the coolant to heat up rapidly during the warm-up phase. However, this only occurs when no heating is required and the outside temperature is within the permitted range.

The coolant pump also operates differently than conventional pumps when controlling the engine temperature. To date, only the currently applied temperature could be controlled by the thermostat.

The software in the engine control unit now features a calculation model that can take into account the development of the cylinder head temperature based on load. In addition to the characteristic map control of the thermostat, the heat management system makes it possible to use various maps for the purpose of controlling the coolant pump. For instance, the engine control unit can adapt the engine temperature to match the current operating situation.

This means that four different temperature ranges can be implemented:

- 108°C ECO mode
- 104°C Normal mode
- 95°C High mode
- 90°C High + map-thermostat mode

The control system aims to set a higher cylinder-head temperature (108°C) if the engine control unit determines ECO (economy) mode based on the engine performance.

The engine is operated with relatively low fuel consumption in this temperature range as the internal friction is reduced.

An increase in temperature therefore favors slower fuel consumption in the low load range. In HIGH and map-thermostat mode, the driver wishes to utilize the optimum power development of the engine. The cylinder-head temperature is reduced to 90°C for this purpose. This results in improved volumetric efficiency, thus increasing the engine torque. The engine control unit can now set a certain temperature mode adapted to the respective operating situation. Consequently, it is possible to influence fuel consumption and power output by means of the cooling system.

The temperatures specified only ever represent a target value, the attainment of which is dependent on many factors. These temperatures are first and foremost not attained precisely.

The consumption-reducing and power increasing effects arise in each case in a temperature spectrum. The function of the cooling system is to provide the optimal cooling output according to the boundary conditions under which the engine is being operated.

The temperatures specified only ever represent a target value, the attainment of which is dependent on many factors. These temperatures are first and foremost not attained precisely.

The consumption-reducing and power increasing effects arise in each case in a temperature spectrum. The function of the cooling system is to provide the optimal cooling output according to the boundary conditions under which the engine is being operated.

Intelligent Heat Management Options

The previous section dealt with the various temperature ranges in which heat management is effected. However, an electrically driven coolant pump makes available even further options. For instance, it is now possible to warm up the engine without recirculating the coolant or to allow the pump to continue to operate after turning off the engine to facilitate heat dissipation. The advantages offered by this type of pump are listed in the following table:



<p>Consumption</p>	<ul style="list-style-type: none"> • Faster warm-up as coolant is not recirculated until needed • Increased compression ratio due to greater cooling output all full load as compared to similar engines without this option
<p>Emissions</p>	<ul style="list-style-type: none"> • Faster engine warm-up by drastically reduced pump speed and the lower volumetric flow of coolant • Reduced friction • Reduced fuel consumption • Reduced exhaust emissions
<p>Power Output</p>	<ul style="list-style-type: none"> • Component cooling independent of engine speed • Requirement controlled coolant pump output • Avoidance of power loss
<p>Comfort</p>	<ul style="list-style-type: none"> • Optimum volumetric flow <ul style="list-style-type: none"> - Heating capacity reduced as required - Residual heat with engine stationary
<p>Component Protection</p>	<ul style="list-style-type: none"> • After-running of electric coolant pump = improved heat dissipation from engine switch off point. Allows protection of turbochargers by reduced oil “coking” during heat soak.

System Protection



In the event of the coolant or engine oil being subject to excessive temperatures while the engine is running, certain functions in the vehicle are influenced so that more energy is made available to the engine-cooling system, i.e. temperature-increasing loads are avoided. These measures are divided into two operating modes:

- Component protection
- Emergency

Measures and Displays for Engine Oil Temperature

Engine oil temp (T-oil C)	Operating mode	Display in Cluster	Power output reduction, Air conditioning	Power output reduction, Engine	Torque converter clutch lockup
148			Start 0 %	Start 0 %	
149			-		
150	Component Protection		-		
151	Component Protection		-	From here = clear reduction	
152	Component Protection		End - 100 %		
153	Component Protection				
154	Component Protection				
155	Component Protection				
156	Component Protection				
157	Component Protection			End @ 90 %	
158	Emergency				Active
159	Emergency				Active
160	Emergency				Active
161	Emergency				Active
162	Emergency				Active
163	Emergency				Active

Measures and Displays for Coolant Temperature

Coolant (T-Coolant)	Operating mode	Display in Cluster	Power output reduction, Air conditioning	Power output reduction, Engine	Torque converter clutch lockup
115					
116					
117	Component Protection		Start 0 %	Start 0 %	
118	Component Protection		-	From here = clear reduction	
119	Component Protection		-	-	
120	Component Protection		End - 100 %	-	
121	Component Protection			-	
122	Component Protection			-	Active
123	Component Protection			-	Active
124	Component Protection			End @ 90 %	Active
125	Emergency				Active
126	Emergency				Active
127	Emergency				Active
128	Emergency				Active
129	Emergency				Active

NOTES

PAGE