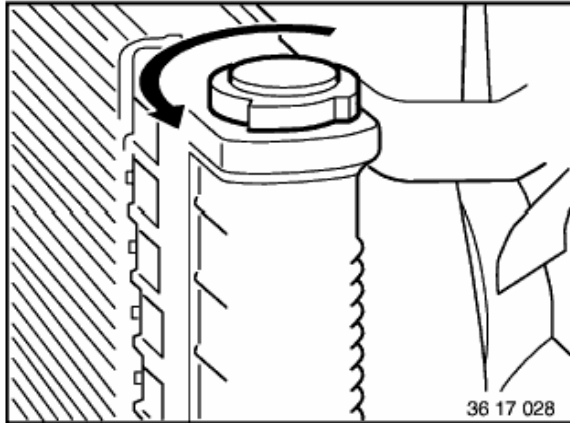

**Warning!**

Danger of scalding!

Only perform this work after engine has cooled down.

**Draining coolant**

Unfasten cap on expansion tank.

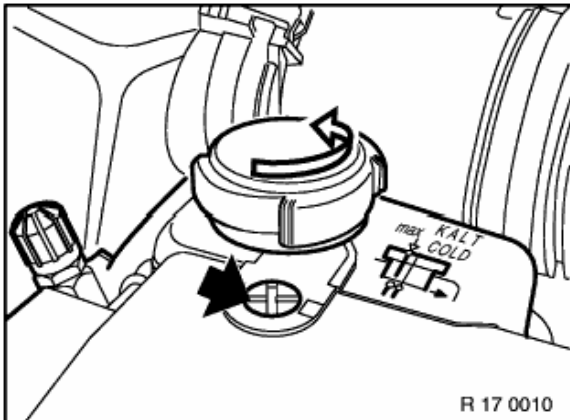
**M62**

Unfasten cap on expansion tank.

Release vent screw.

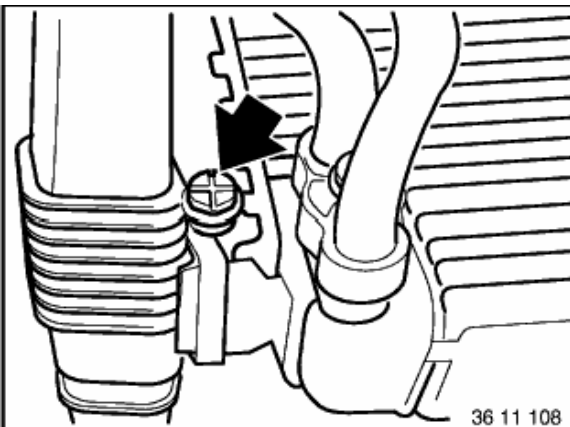

If necessary, remove front underbody protection from units.

Unscrew drain plug at bottom of radiator.

**Installation:**

Replace seal.

Tightening Torque,

refer to Technical Data 17 11 2AZ.

Drain, catch and dispose of coolant.

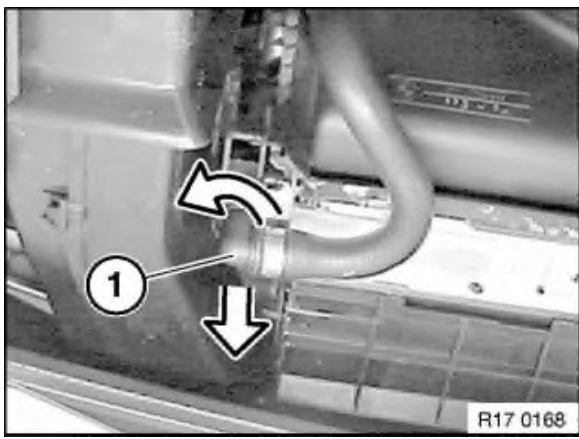

### M62

If necessary, remove front underbody protection from units,

Cars with automatic transmissions:

Turn hose plug (1) to left and detach towards bottom.

Cars with manual transmission:

Remove drain plug at bottom of radiator.

Drain, catch and dispose of coolant.

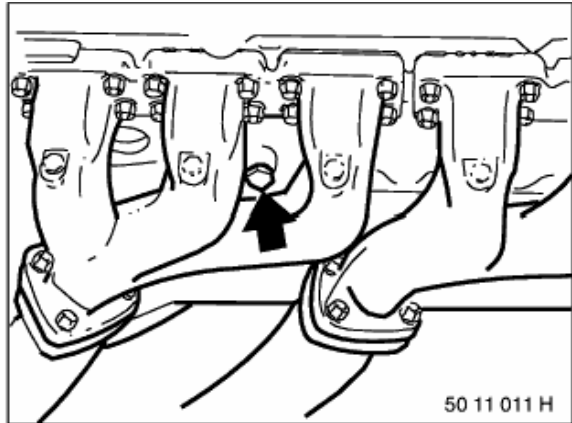

Unfasten drain plug(s) on engine block.

### M62

Remove drain plugs on left and right of engine block.

### Installation:

Replace seal.

Tightening Torque,

refer to Technical Data 11 11 5AZ.

Drain off and catch coolant.

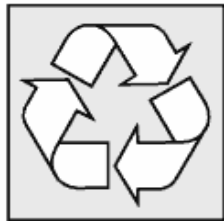

### Recycling

Dispose of drained coolant.

Observe country-specific waste-disposal regulations.

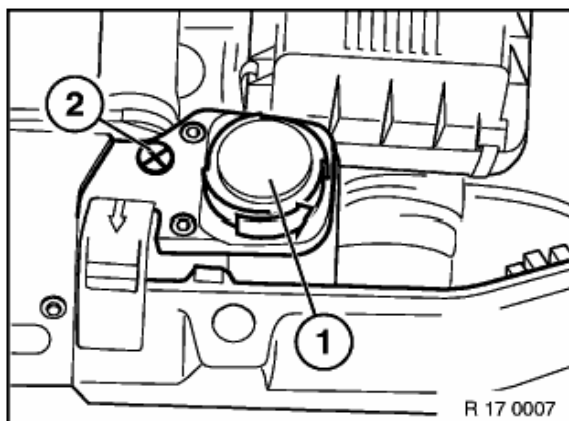

### Top up coolant!

Slacken vent plug (2) on expansion tank.



On cars with latent heat accumulators, do not turn on ignition when filling cooling system.

Follow venting procedure specified in MG64, refer to 64 12 ...

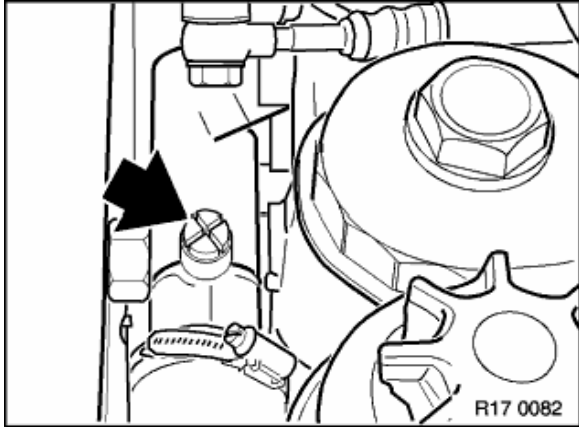

On vehicles with M52 engines, also unfasten additional vent screw.

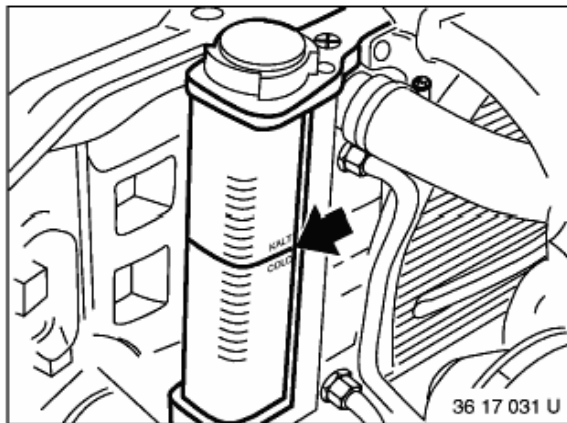

**Note:**

Turn on ignition. Set heater control to maximum temperature. Set blower to low level. This opens the heating valves and sets the auxiliary water pump in operation.

Perform filling operation slowly.

Fill up expansion tank fully and wait until bubble-free coolant emerges from vent plug. Tighten down vent plug.

**Note:**

Use only recommended coolant, refer to BMW Operating Fluids MG 17.

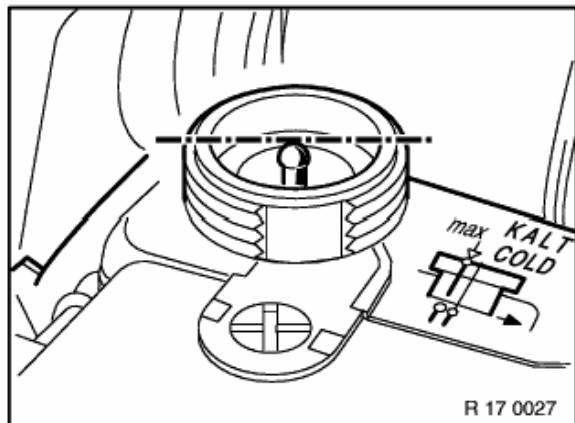

**M62**

**Note:**

Turn on ignition. Set heater control to maximum temperature. Set blower to low level. This opens the heating valves and sets the auxiliary water pump in operation.

Perform filling operation slowly.

Fill up expansion tank fully and wait until bubble-free coolant emerges from vent plug. Tighten down vent plug.

**Note:**

Use only recommended coolant, refer to BMW Operating Fluids MG 17.

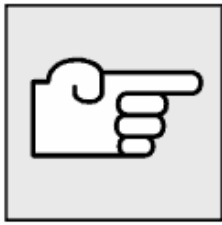

**Note:**

Vent cooling system and check for leaks,  
refer to 17 00 039.