

Suck the fuel out of the fuel tank,
refer to 16 00 005

Remove rear bench seat.
Unfasten rubber grommet.

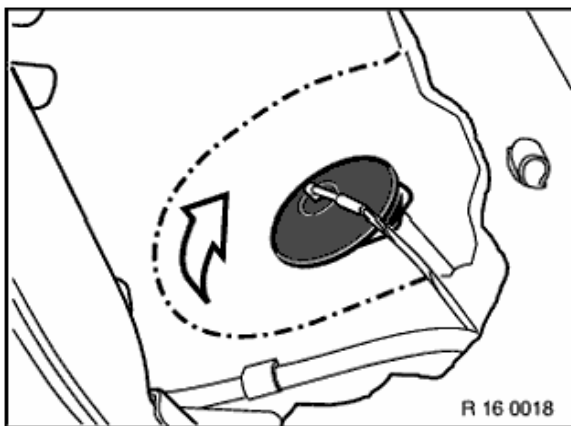

Cut insulating mat along perforated line and fold open.

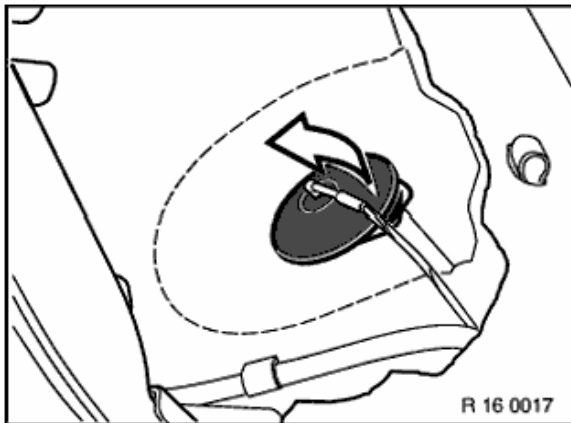
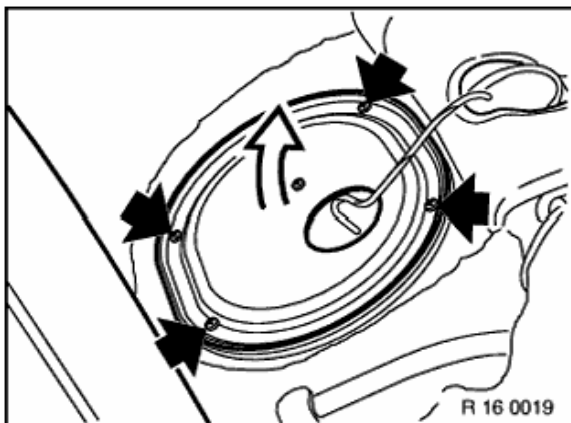

Remove cover.

Installation:

Note gasket.

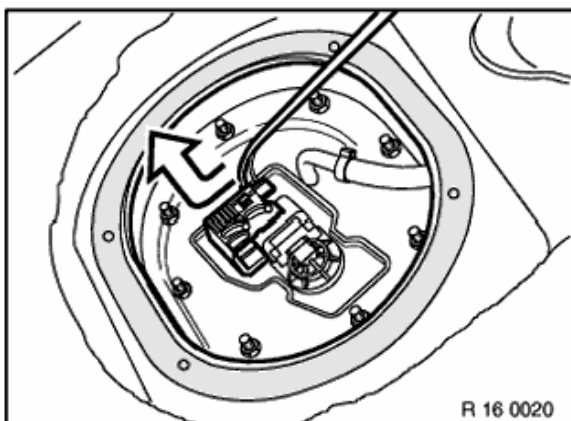

Disconnect plug connection.

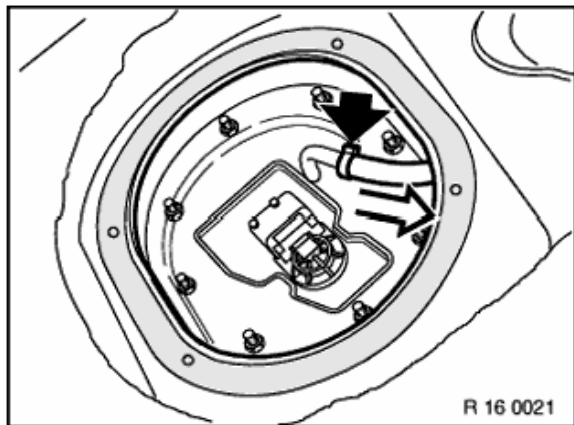

Disconnect the fuel pipe with special tool 13 3 010 and open the hose clamp.

Petrol-driven vehicles - inlet line

Diesel-driven vehicles - return line

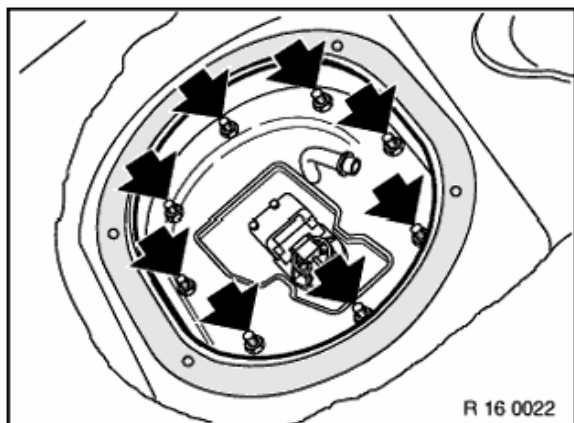

Unscrew and remove nuts.

Installation:

Tighten nuts crosswise.

Tightening Torque,

refer to Technical Data 16 14 3AZ

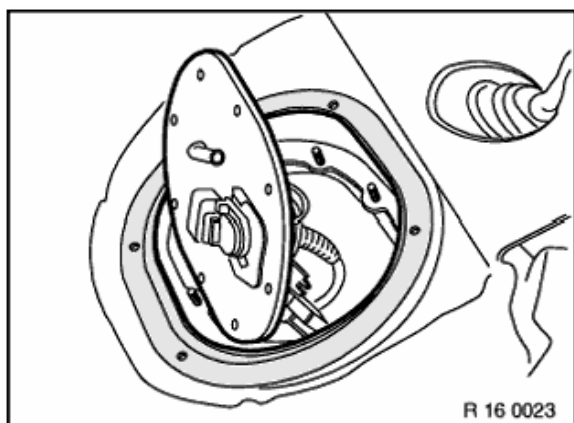

Caution!

Expose the connector hose under the lid.

Lift up the lid as far as it will go and swing it up.

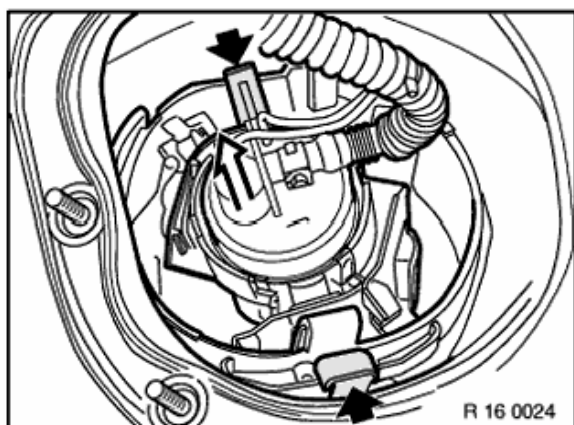

Compress retaining hook on fuel pump (black housing).

Remove fuel pump from fuel baffle (white housing).

Installation:

Ensure that both retaining hooks locate perfectly. Check that the O-ring on the connection is perfectly seated. If necessary, carefully press down until it is correctly seated.

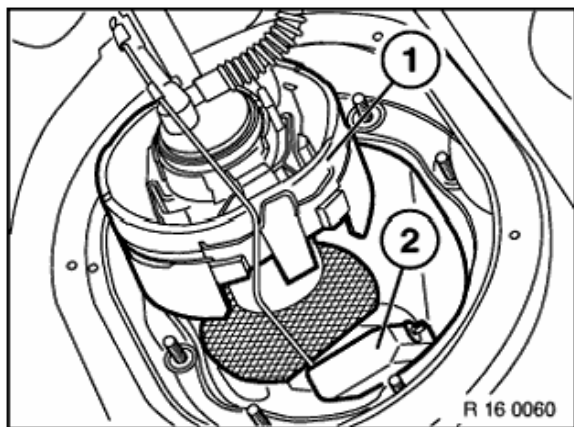

Caution!

Do not bend sensor.

Remove fuel pump (1) and sensor (2) together.

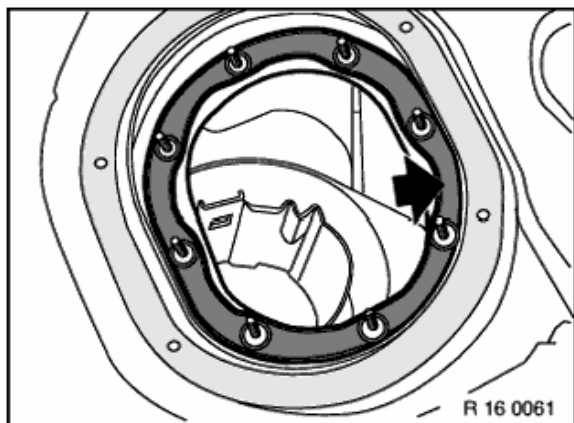

Installation:

Replace rubber gasket.

Caution!

The "red silicone seal" used as protection against dust and dirt during transport may never be used for installation of the fuel level sensor. This transport seal is not fuel-resistant and will result in leakage of the fuel level sensor.

Remove the fuel pump from the sensor.

Note:

The sensor is delivered completely with connector hose and plug connection.

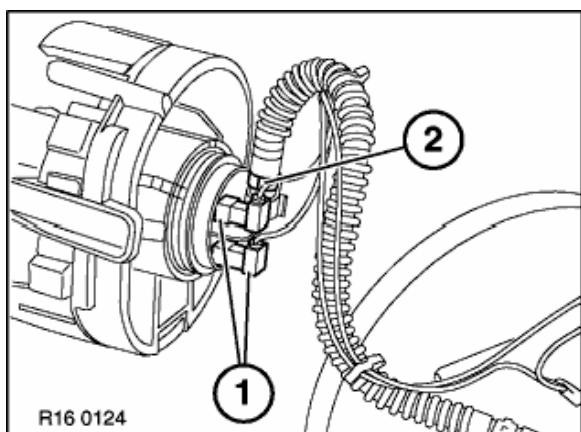

Caution!

Disconnect both plug connections (1) on the fuel pump.

The retaining hooks on the plug connections (1) make disconnection more difficult. Separating them forcefully can cause damage.

From 01/96, optimised plug connection (1) with black plastic housing. These automatically disconnect when the connector housing is pulled.

Unfasten hose clip (2) and carefully remove spiral hose, avoiding damage to pump neck.

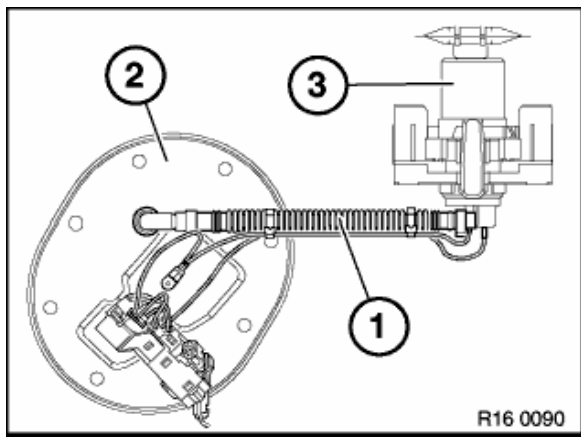

Spark ignition engines

Installation:

In order to avoid twists, align the connector hose and cable (1) between the lid (2) and fuel pump (3) before installing.

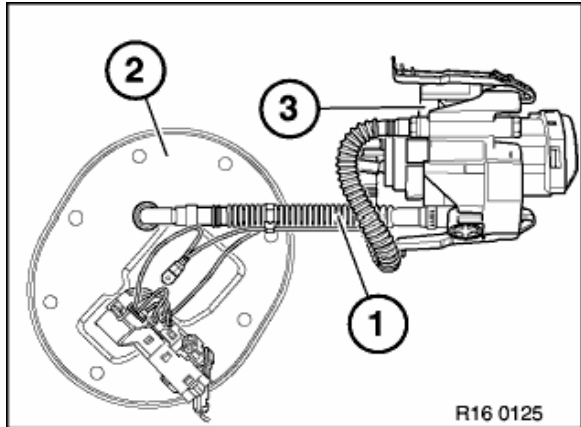

Diesel engines

Installation:

In order to avoid twists, align the connector hose and cable (1) between the lid (2) and fuel pump (3) before installing.