

Note:

If the drive belt is to be subsequently reused:

Mark direction of travel and reinstall drive belt in same direction of travel.

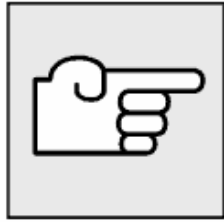

Remove fan clutch with impeller,
refer to 11 52 020.

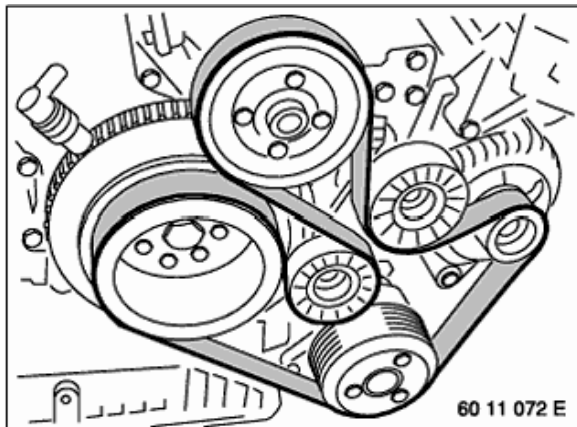

Layout of drive belt.

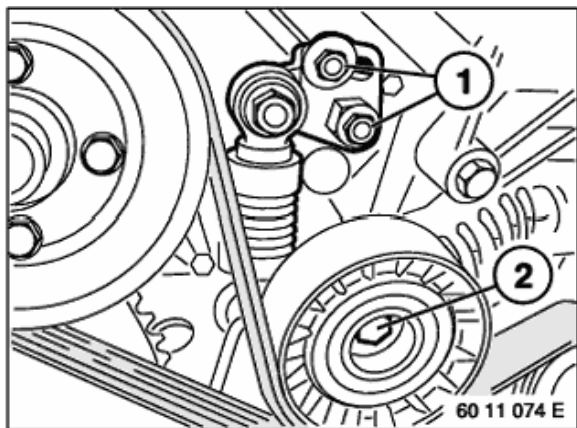

Slacken screws (1) and relieve tension on belt drive.

Note:

Release screws (1 and 2) to remove complete belt tensioner.

Remove drive belt.

Caution!

You must replace the drive belt if it is contaminated with hydraulic fluid.

Installation:

Check drive belt for coolant and oil residue and replace if necessary.

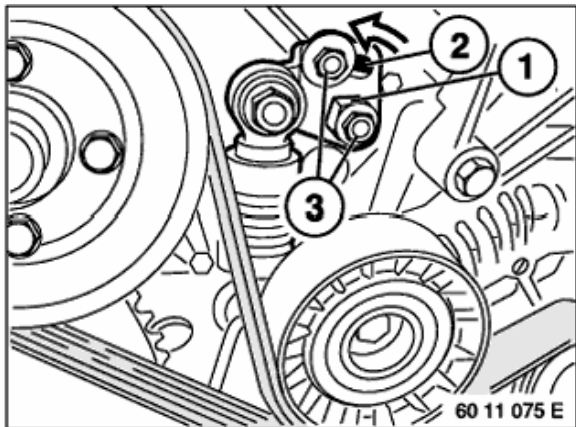

Installation:

Mount drive belt and check that it is correctly positioned on belt pulleys.

Pretension adjustable plate at hexagon head (1) up to end of elongated hole (2) and tighten down screws (3).

Caution!

Screws (3) up to 9/98

M8 strength class 8.8 tightening torque 22 Nm.

Screws (3) from 9/98 with liquid-cooled alternator

M8 strength class 10.9 tightening torque 30 Nm.