

8 Series

meeknet.co.uk



Owner's Handbook



840Ci
850Ci
850CSi

840C1
850C1
850C21

Congratulations on your choice of a BMW.

The better you are acquainted with your car, the easier you will discover driving to be. We would therefore like to offer you the following advice.

This Owner's Handbook contains important information on operating and maintaining your BMW. It contains important hints on correct operation of the controls, so that you benefit fully from your BMW's many advanced technical features. There are also full details of maintenance and general care, with the aim of keeping your car fully operational and safe at all times and maintaining its value.

Wishing you many enjoyable and safe journeys.

BMW AG

Before you read this Owner's Handbook, here are some important items of information:

When you purchased the vehicle, you chose a specific model and a range of equipment to suit your preferences. This handbook describes all the models and equipment developed by BMW within its 8 Series.

Right-hand-drive cars may have controls and equipment located in different places from those described here.

Refer to the keyword index as a rapid means of finding the topic you need.

Descriptions of items of equipment not found in this handbook are given in the installation or operating instructions accompanying such items. Your BMW Service station will gladly advise you.

We have used the following symbols in the pages of this handbook:

 indicates information which you should definitely have read for your own safety and to protect your car against damage or defects. ◀

 is used to identify details of special features. ◀

* identifies optional extras, national-market equipment and accessories.

 refers to recycling procedures. ◀

If you have any further queries, your BMW Service station will gladly advise you.

 Important safety information: for your own safety, always use parts and accessories which have been approved by BMW.

Parts approved by BMW have been tested for safety, function and suitability for use on BMW vehicles. BMW accepts product liability for parts it has approved.

BMW is unable to accept any form of liability for parts, accessories or other products which it has not approved.

BMW clearly cannot assess every product of outside origin in order to ensure that it represents no risk of injury to the user if installed or operated with a BMW automobile. Nor can approval by an official technical inspection authority or the issue of a general operating permit by a government body provide absolute assurance that a product is entirely suitable, since the tests performed by such bodies tend to be of a more general nature only.

Original BMW Parts and Accessoires and other products approved by BMW are available from BMW Service, which will gladly provide competent advice on all related matters.

The functional efficiency and road safety of your BMW and its resale value may be adversely affected if changes not in accordance with its general operating permit or the manufacturer's specification are made to its equipment.

All dimensions, weights and performance data stated in this Owner's Handbook are in accordance with the relevant German Industrial Standards (DIN) and the tolerances laid down for them. National-market versions may differ from those described here.

Fuel consumption figures are as determined at the time of closing for press.

The high safety and quality standards of BMW vehicles are upheld by ongoing development in the design, equipment and accessories areas. This may give rise to discrepancies between the contents of this Owner's Handbook and your own vehicle. Nor can errors and omissions be entirely ruled out. You are therefore asked to appreciate that no legal claims can be entertained in respect of the data, illustrations or descriptions quoted here.

Table of Contents

Important facts in brief

Cockpit 12
Instrument cluster 14
Telltale and warning lights 16
Distance recorder 18
Revolution counter 18
Fuel gauge 19
Coolant temperature gauge 19
Ignition/starter switch and steering lock 20
Starting the engine 21
Stopping the engine 21
Running in 22
Refuelling 23
Tyre pressures 24

Controls

Electronic immobilizer 26
Keys 26
Doors 27
Luggage compartment 29
Key with radio remote control 30
Radio remote control 30
Alarm system 34
Seats 36
Steering column adjustment 38
Electric steering wheel adjustment 39
Mirrors 41
Position memory for seats, mirrors and steering wheel 42
Seat belts 42
Airbag restraint system 44
Main light switch 45
Fog light switch 46
Turn indicators/low beams 46
Hazard warning flashers 47
Interior light/footwell lights 47
Headlight beam throw adjustment 48
Wipe/wash system 48
Electric windows 50
Sunroof 51
Multi-Information Display (MID) 52
Service Interval indicator 53
Digital clock 54
On-board computer 56
Check Control 64
Handbrake 66

EML 67
Manual gearbox 67
Automatic transmission 68
Automatic transmission with STEPTRONIC 70
Cruise control 73
EDC 74
ASC+T 74
DSC 76
Automatic air conditioning 78
Heated rear window 83
Independent heating 84
Independent ventilation 84
Roller sunblind 85
Glove boxes 85
Ashtray 86
Rear seat back 87
Ski bag 87

Operating hints

Driving hints 90
Car radio operation 91
Car telephone 91
Engine compartment lid 92
Vehicle identification number 93
Type plate 93
Engine compartment - BMW 840Ci 94
Engine compartment - BMW 850Ci/850CSi 96
Engine oil 98
Hydraulics 100
Hydraulics and AHK 100
Brake fluid 101
Coolant 102
Washer fluid for the cleaning systems 103
Washer jets 104
Power steering 105
Brakes 105
Batteries 106
Fuses 108
Toolkit 109
Warning triangle 109
Fire extinguisher 109
First aid box 110
Tow-starting, towing away 110
Tow-starting 111
Towing away 111
Starting with a flat battery 112
Changing a wheel 113
Thiefproof wheel studs 116

Fuel filler flap 116
Luggage compartment 117
Sliding/tilt roof 117
Headlights 117
Renewing wiper blades 118
Bulb-changing 119
Winter operation 124
Towing a trailer 125
Roof rack 128
Right/left rule of the road 128
Licensing car for use abroad 129
ABS 129
Active Rear Axle Kinematics (AHK) 131
Disc brakes 132
Tyre pressure 133
Tread depth 133
New tyres 134
Interchanging wheels and tyres 134
The correct choice 135
Winter tyres 136
Approved wheels and tyres 137
Technical modifications 138

Care and maintenance

The BMW maintenance system 140
Care of the care 141
Laying the car up out of use 146

- Engine data 148
- Fuel consumption, carbon dioxide/CO₂ emissions 149
- Dimensions 150
- Weights 151
- Performance 152
- Filling capacities 153
- Electrical system 154
- V-belts 154

From A to Z 156

- Cockpit 12
- Instrument cluster 14
- Telltale and warning lights 16
- Distance recorder 18
- Revolution counter 18
- Fuel gauge 19
- Coolant temperature gauge 19
- Ignition/starter switch and steering lock 20
- Starting the engine 21
- Stopping the engine 21
- Running in 22
- Refuelling 23
- Tyre pressures 24

Important facts in brief

Controls

Operating hints

Care and maintenance

Technical data

Index

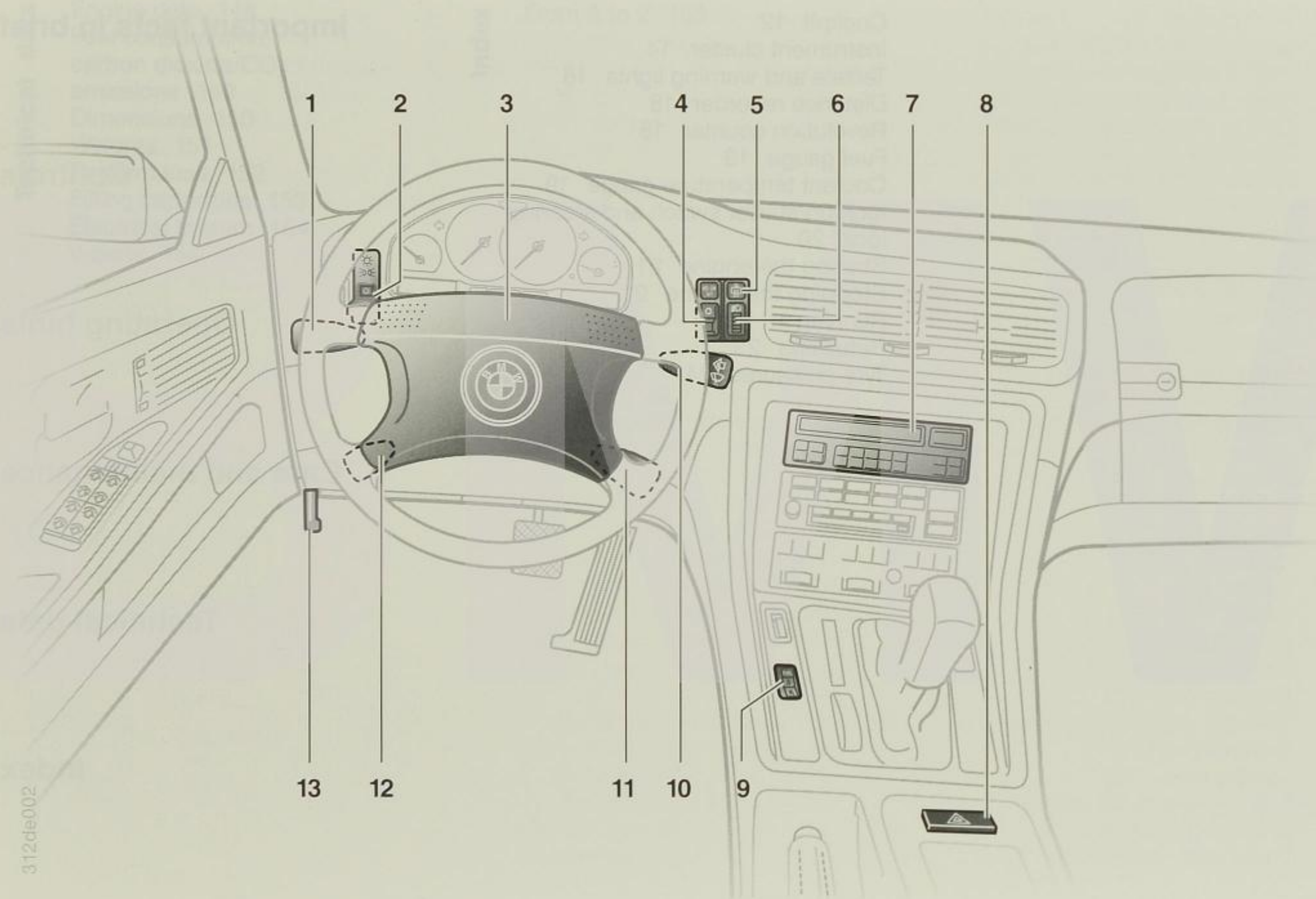

312de002

- 1 Lever for flashing turn indicators, parking lights, dipped headlights and headlight flasher 46
- 2 Main light switch 45
- 3 Horn
- 4 Fog light switch 46
- 5 Switch for heated rear window 83
- 6 Knurled wheel for headlight beam throw adjustment 48
- 7 Multi-Information Display (MID) 52
- 8 Switch for hazard warning flashers 47
- 9 Switch for programmable electronic output control (EML), (BMW 850CSi only) 67
- 10 Wipe/wash control lever 48
- 11 Cruise control lever 73
- 12 Lever for electric steering-wheel adjustment 39
- 13 Engine compartment release lever 92

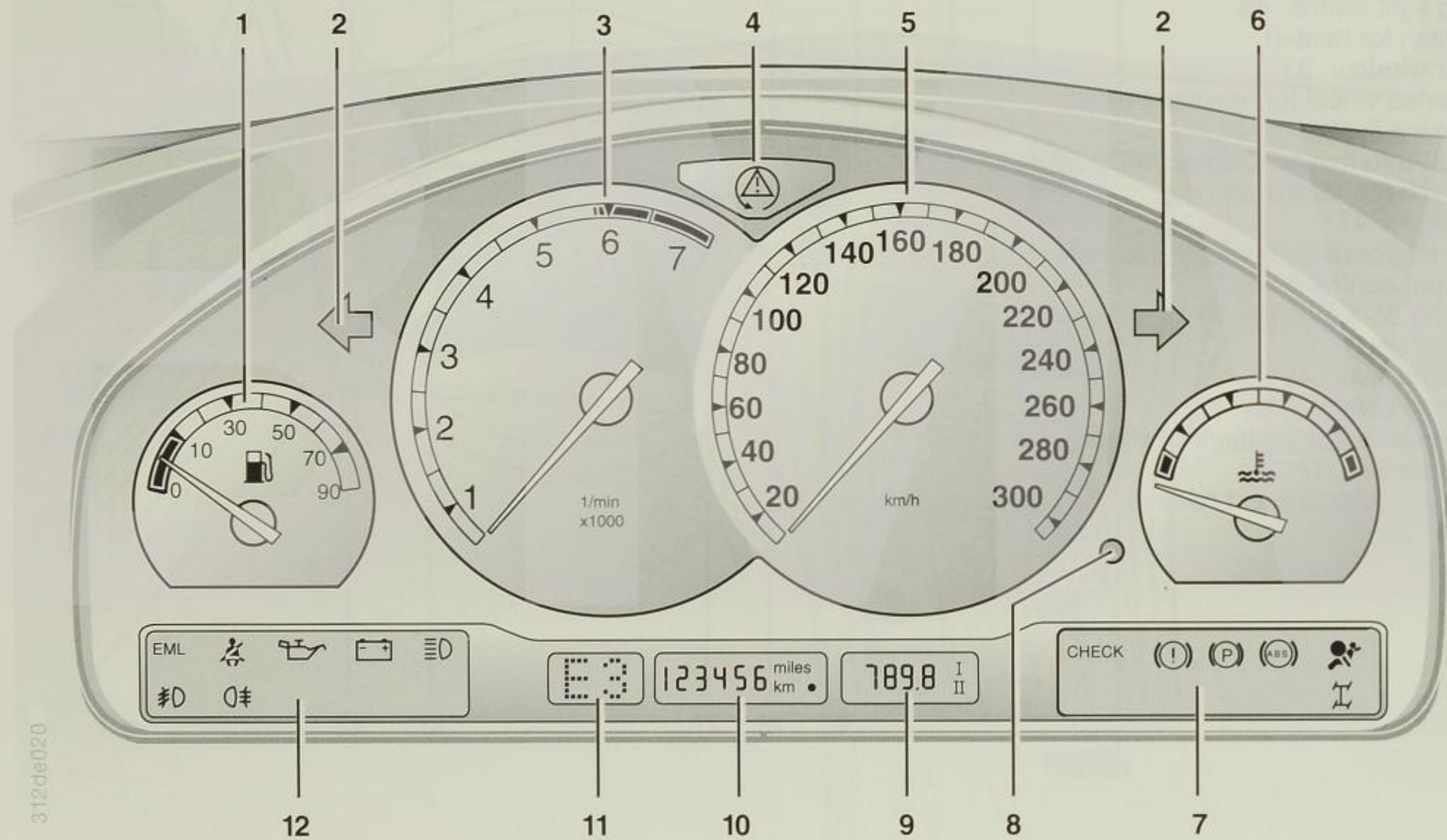

312de020

- 1 Fuel gauge with warning light for reserve supply 19
- 2 Turn indicator repeaters 16
- 3 Revolution counter 18
- 4 Telltale light for ASC+T/DSC 16
- 5 Speedometer
- 6 Coolant temperature gauge 19
- 7 Check control indicator light and telltale and warning lights for break system and steering hydraulics, handbrake, ABS, AIRBAG, AHK and trailer flashing turn indicators 64, 17
- 8 Trip distance reset knob and changeover knob for distance display 18
- 9 Trip distance recorder 18
- 10 Distance recorder 18
- 11 Driving program and selector lever position indicator for automatic transmission (on BMW 850CSi, with S display for electronic output control Sport program). 67, 68
- 12 Telltale and warning lights for electronic power control (EML), engine oil pressure, battery charge, high-beam headlights and front and rear fog lights 16

Indicator for ASC+T and DSC (Automatic Stability Control plus Traction/Dynamic Stability Control)

 Goes out when engine is started if system is in working order.

Further details: pages 74, 76.

Left/right flashing turn indicator

 Comes on rhythmically when the flashing turn indicators are in use.

Electronic engine output control

 Comes on briefly when the ignition is switched and goes out again if system is in working order.

If the light remains on or comes on again during a journey, the system is defective. However, the car can still be driven and should be taken to the nearest BMW service station.

Fasten seat belt*

 Possibly together with an acoustic signal* and/or warning on * Multi-Information Display (MID).

Comes on briefly when the ignition is switched on then goes out (depending on version, signal may go out only after the seat belt has been fastened).

Engine oil pressure

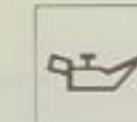
 Goes out when the engine is started. This light may come on at idle speed if the engine is hot but must go out again at higher engine speeds.

If the light comes on during a journey and the "ENGINE OIL PRESS LOW" display appears in the Multi-Information-Display (MID): stop the car and switch off the engine at once. Check engine oil level and top up if necessary. If the oil level is correct: consult a BMW Service station.

Battery charge

 Goes out when the engine is started

If it comes on during a journey, The batteries are no longer being charged. The alternator drive V-belt has failed or there is a fault in the alternator charge circuit.

 If the V-belt is defective, increased steering and braking effort will be needed. ◀

Cars with a second alternator*: A second bulb in the telltale monitors the charge current for the second alternator. If the main alternator should fail, the car can still be driven for approx. 2 hours with the telltale light on, provided that no additional electrical consumers are switched on.

High-beam headlights

 Comes on when the high-beam headlights are in use or the headlight flasher is operated.

Fog lights

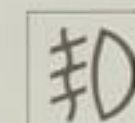
 Comes on when the fog lights are switched on.

Rear fog light

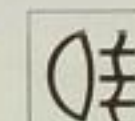
 Comes on when the rear fog lights are switched on.

Brake and steering hydraulics

 Goes out when the engine is started.

If it comes on during a journey accompanied by the "LOW BRAKE FLUID" display in the Multi-Information Display (MID): brake fluid level is too low.

If it flashes during a journey and the "BRAKE ASSIST INACT." display appears in the MID:

loss of pressure in the brake system or power steering circuit.

 In both cases, increased steering and braking effort will be needed. ◀

Further details: pages 100, 105.

Handbrake

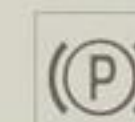
 Goes out when the engine is started.

Comes on when the handbrake is applied.

Antilock brake system (ABS)

 Goes out when the engine is started.

If it comes on during a journey, the ABS has ceased to operate because of a malfunction. The car can still be braked in the usual way without any loss of efficiency.

Further details: page 129.

Telltale for airbag restraint system

 Telltale comes on for approx. 6 seconds and then goes out.

Further details: page 44.

AHK (Active Rear Axle Kinematics)

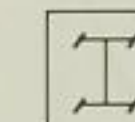
 Goes out when the engine is started if system is in working order.

If it comes on during a journey and the "R/AXLE FAILSAFE PROG" display appears in the Multi-Information Display (MID):

The AHK has cut out as a result of a fault. The car can still be driven. If the steering wheel is slightly off-centre when driving in a straight line, the car will veer slightly from the chosen line of travel.

Further details: page 131.

Trailer flashing turn indicators

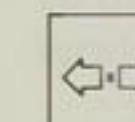
 Flashes together with the main turn indicator repeater if a turn is signalled while a trailer is being towed.

Further details: page 125.

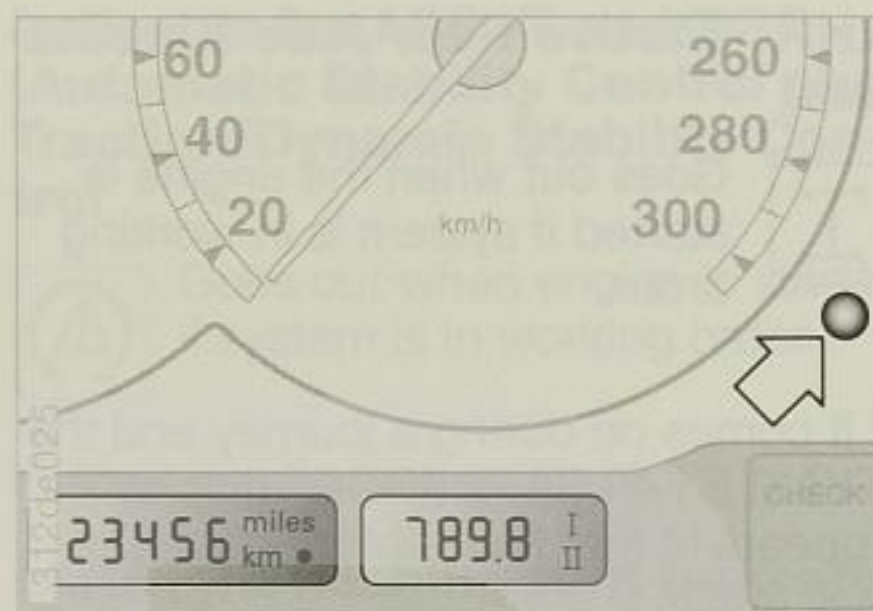

The distance recorder shows the total distance which the car has covered in miles or kilometres.

Trip distance displays I and II

You can choose between two trip distance displays (e.g. one for the whole journey and one for a specific period of driving only) and reset either of them to zero independently. Both displays show distances up to 999.9 miles/km.

Changeover(I-II-I etc.):

- ▷ Turn the reset knob (arrow) clockwise.

Resetting to zero:

- ▷ Select the desired display first, then press the reset knob. Up to two minutes after the ignition has been switched off, the display remains visible and adjustments are possible. When the distance display is not visible, it can be recalled for a short period of time by pressing the reset knob.



Never allow the engine to run in the red zone of the revolution counter.

In this zone the fuel supply is interrupted to protect the engine. This becomes evident by intermittent ignition cut-out.

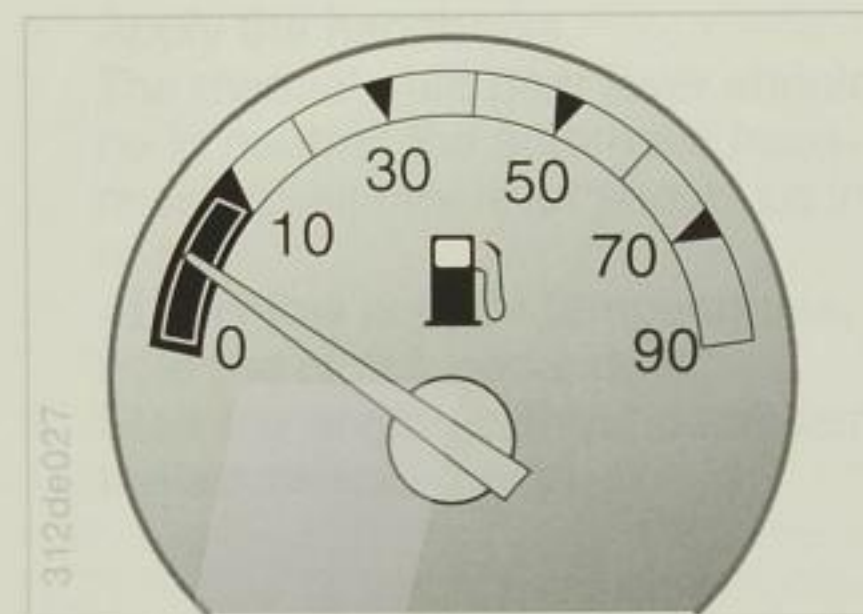

The warning light comes on briefly as an operating check when the ignition is switched on.

When the warning light comes on, there are about 10 litres of fuel left in the tank.

Please refuel in good time, as running the tank too low could cause damage to the engine or the catalytic converters.

You can display the probable range on the fuel remaining in the tank on the on-board computer. See page 57.



If the car's body is at an unusual angle, e.g. during a lengthy uphill run, the display readings may fluctuate slightly.

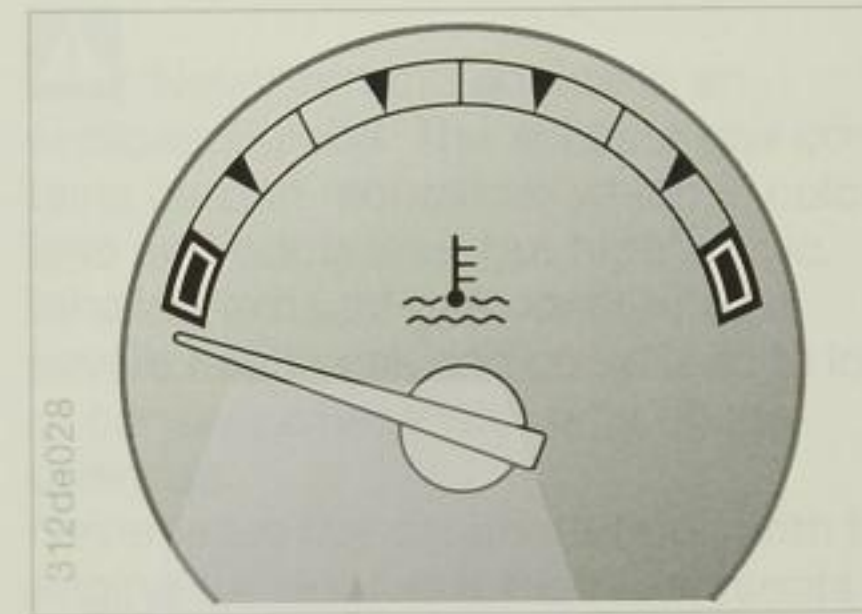

Blue:

the engine is cold. Drive at moderate engine and road speeds.

Red:

with "COOLANT TEMPERATURE" display in MID: the engine is too hot. Switch it off at once and allow to cool down.

Pointer between the two coloured zones:

normal operating temperature. At high outside temperatures or when loads on the car are severe, the pointer may move up as far as the beginning of the red zone.

Checking coolant level: page 102.

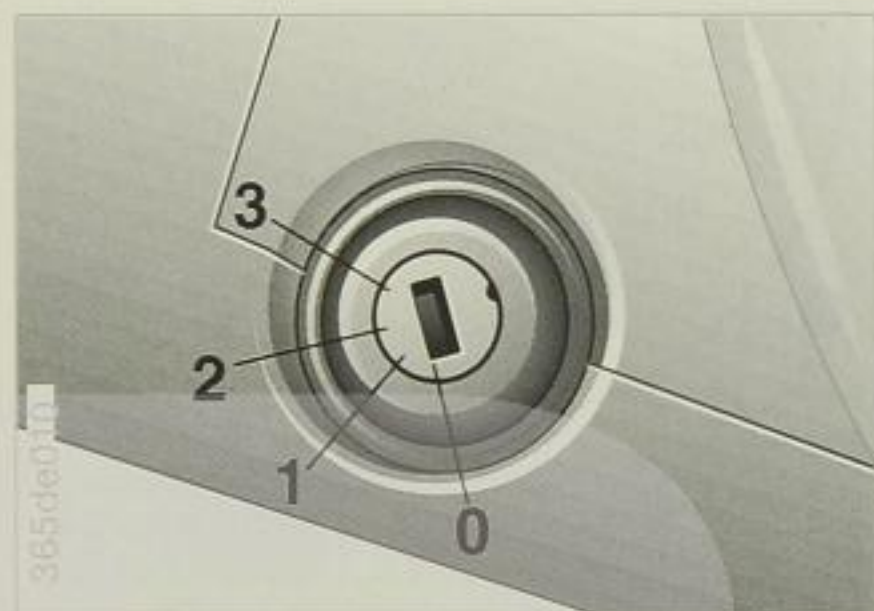

0 Steering locked.

The key can only be inserted and removed in this position.

After removing the key, turn the steering wheel slightly if necessary until the steering lock engages.

1 Steering released

Move the steering wheel slightly if necessary to facilitate turning the key from 0 to 1.

2 Ignition switched on

All electrical consumers are ready to operate.

3 Starter motor operated

Starting the engine

- ▷ Apply the handbrake.
- ▷ The manual-shift gear lever should be in neutral; the automatic transmission selector lever should be in P or N.
- ▷ At very low outside temperatures, hold the clutch pedal down.
- ▷ Start the engine without depressing the accelerator pedal.

▶ Allow the starter motor to run for a reasonable time, but not for more than about 20 seconds. As soon as the engine fires, release the ignition key. Do not allow the engine to warm up at a standstill, but drive off as soon as possible, using moderate engine speeds. ◀

If the engine does not start first time, for instance if it is very cold or very hot:

- ▷ Observe a slight pause before operating the starter motor again, to prevent the spark plugs from becoming wet with excess fuel.
- ▷ Depress the accelerator pedal halfway while starting the engine.

⚠ Never run the engine in an enclosed space. The exhaust gas contains carbon monoxide, which is colourless and odourless, but highly toxic. Inhaling exhaust gas constitutes a severe health risk and could lead to loss of consciousness with fatal consequences. Never leave the car unattended with the engine running, as it then represents a serious potential hazard. ◀

Stopping the engine

Turn the ignition key back to 1 or 0.

⚠ Never take the ignition key out when the car is still in motion, or the steering lock will engage. Whenever the driver leaves the car, he or she should remove the ignition key and lock the steering. Manual-gearbox cars: when parking the car on a slope, apply the handbrake, as merely selecting 1st gear or reverse may not be sufficient to prevent the car from rolling away. Automatic-transmission cars: select position P. ◀

Please comply with the following instructions, which are intended to ensure that your car achieves its optimum operating life and economy.

Engine and final drive BMW 840Ci, 850Ci
Up to a speedometer reading of 2000 km (approx. 1250 miles):

Drive the car at varying engine and road speeds, but do not exceed an engine speed of 4500/min or a road speed of 170 km/h (106 mile/h).

Avoid the full-throttle position of the accelerator and do not use the automatic transmission kick-down.

After 2000 km (approx. 1250 miles) have been covered, engine and road speeds can be gradually increased.

If the engine or final drive is exchanged later in the car's life, repeat the running-in procedure.

BMW 850CSi
Up to a speedometer reading of 2000 km (approx. 1250 miles):

Do not exceed a max. engine speed of 5500/min.

Max. road speed 160 km/h (100 mile/h).

Do not use the full throttle position of the accelerator.

Up to a speedometer reading of 5000 km (approx. 3100 miles):

Max. continuous road speed 200 km/h (124 mile/h).

Use top speeds for short periods only.

If the engine or final drive is exchanged later in the car's life, repeat the running-in procedure.

Tyres

For production reasons, new tyres do not achieve their full road grip immediately. You should therefore drive in a restrained manner for the first 300 km (approx. 200 miles).

Brakes

Brake pads and discs do not achieve a favourable wear and contact pattern until the car has covered about 500 km (300 miles).

To eliminate brake corrosion, apply the handbrake lightly as the car coasts to a halt, for instance at a traffic signal, provided that this does not endanger other road users.

 The brake lights do not come on when the handbrake is applied. ◀

Refuelling

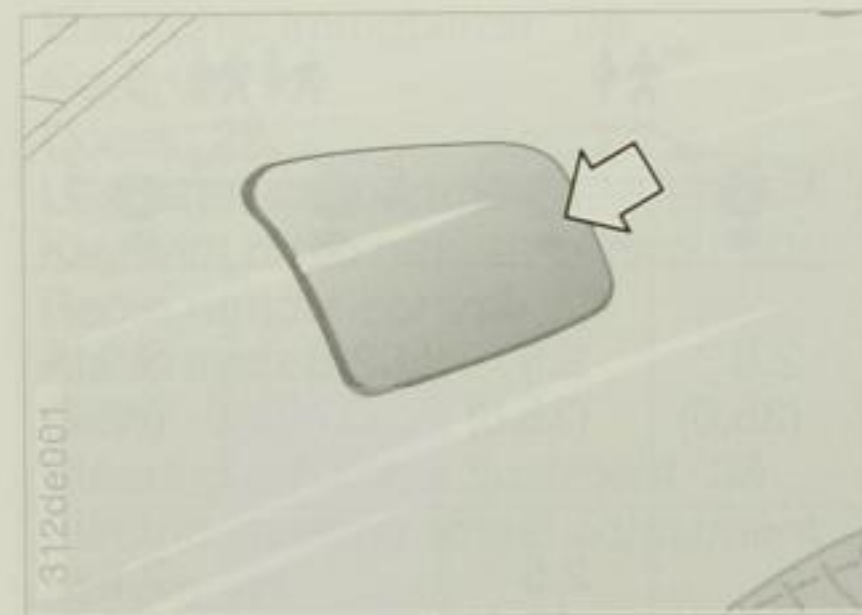

To open the fuel filler flap, press the front end in so that the flap can be lifted.

 When refuelling, insert the filler nozzle in the mouth of the fuel tank. If the filler nozzle is raised during refuelling,

- ▷ the supply of fuel will be cut off prematurely
- ▷ On filler nozzles with fuel vapour recovery, the recirculating function will be less effective.

To release the fuel filler flap if the central locking system fails, see page 116.

 Comply with the relevant safety regulations when handling fuel. ◀

Fuel grade required

Cars with catalytic converter:

Premium-grade unleaded fuel to DIN EN 288 standard or equivalent, octane number 95 (Research Method). This fuel is also known as "Euro-Super."

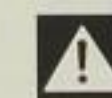
 Never use fuel containing lead, or the oxygen sensor and catalytic converter will be permanently damaged. ◀

Cars without catalytic converter
 (catalytic converter can be retrofitted):

Premium-grade unleaded fuel to DIN EN 288 standard or equivalent, octane number 95 (Research Method) (Euro-Super)

or premium-grade fuel to DIN 51 600 standard or equivalent, octane number 98 or premium-grade fuel with octane number 95 (Research Method).

Since the engines have a knock control function, they can run on different grades of fuel – Minimum grade: regular fuel (octane number 91 (Research Method)).

The rated performance and fuel consumption values are achieved with premium-grade fuel (octane number 95, Research Method). If a higher quality is used – for example Super Plus (98 RON) – power output increases and fuel consumption improves: if the fuel quality is poorer, the reverse applies.

Check regularly for your personal safety:

Incorrect tyre pressures can render the car unstable and lead to tyre damage or even cause an accident. ◀

Tyre pressures in bar – gauge pressure – (psi) with tyres cold (cold = ambient temperature).

These tyre pressures apply to makes of tyre approved by BMW and known to the BMW Service Organization.



If other makes of tyre are fitted to the car, higher tyre pressures may be needed.

The information relevant to your car is shown on a label attached to the driver's door post.

When towing a trailer, always use the values for the higher load.

Tyre Chart Explanations

- *) Only permissible as mixed set with 235/45 R 17 93 W at front.
- ***) Only permissible as mixed set with 235/45 ZR 17 at front.
- ***) Only permissible as mixed set with 245/40 ZR 18 at front.

BMW model	Tyre sizes				
		Front	Rear	Front	Rear
840Ci 850Ci	235/50 R 16 95 W 225/55 R 16 95 Q, T, H M+S 235/50 R 16 95 Q, T, H M+S	2.5 (35.6)	2.5 (35.6)	2.6 (37.0)	3.0 (42.7)
	265/40 R 17 96 W* 265/40 ZR 17**	–	2.5 (35.6)	–	2.8 (39.8)
850CSi	235/45 R 17 93 W 235/45 ZR 17 235/45 R 17 93 Q, T, H M+S	2.7 (38.4)	2.7 (38.4)	2.8 (39.8)	3.2 (45.5)
	235/45 ZR 17 265/40 ZR 17**	2.9 (41.3)	2.9 (41.3)	3.2 (45.5)	3.2 (45.5)
850CSi	235/45 R 17 93 Q, T, H M+S	2.5 (35.6)	2.7 (38.4)	2.7 (38.4)	3.0 (42.7)
	245/40 ZR 18 285/35 ZR 18***	2.9 (41.3)	–	3.2 (45.5)	–

Electronic immobilizer 26
Keys 26
Doors 27
Luggage compartment 29
Key with radio remote control 30
Radio remote control 30
Alarm system 34
Seats 36
Steering column adjustment 38
Electric steering wheel adjustment 39
Mirrors 41
Position memory for seats, mirrors and steering wheel 42
Seat belts 42
Airbag restraint system 44
Main light switch 45
Fog light switch 46
Turn indicators/low beams 46
Hazard warning flashers 47
Interior light/footwell lights 47
Headlight beam throw adjustment 48
Wipe/wash system 48
Electric windows 50
Sunroof 51
Multi-Information Display (MID) 52
Service Interval indicator 53
Digital clock 54
On-board computer 56
Check Control 64
Handbrake 66
EML 67
Manual gearbox 67

Automatic transmission 68
Automatic transmission with STEPTRONIC 70
Cruise control 73
EDC 74
ASC+T 74
DSC 76
Automatic air conditioning 78
Heated rear window 83
Independent heating 84
Independent ventilation 84
Roller sunblind 85
Glove boxes 85
Ashtray 86
Rear seat back 87
Ski bag 87

Important facts in brief

Controls

Operating hints

Care and maintenance

Technical data

Index

The electronic immobilizer reduces the likelihood of your BMW being stolen. It prevents the engine from being started except with the car's correct keys.

In addition to the mechanical matching of lock and keys, this is achieved by a special electronic component integrated into the key.

The vehicle's electronics exchange constantly-updated signals, which are individualized for every vehicle, via the ignition switch with the electronic components in the key. The ignition, fuel supply and starter motor cannot operate until the key has been identified as valid.



The electronic components in the key could become damaged if treated violently. This could prevent you from starting the engine. ◀

Obtaining a new key:

Spare keys are only available from a BMW Service station, which is obliged to check that you are entitled to order them.

BMW Service can also invalidate individual keys (e.g. if they are lost) or reinstate them. The engine cannot be started with an invalidated key.

Keys

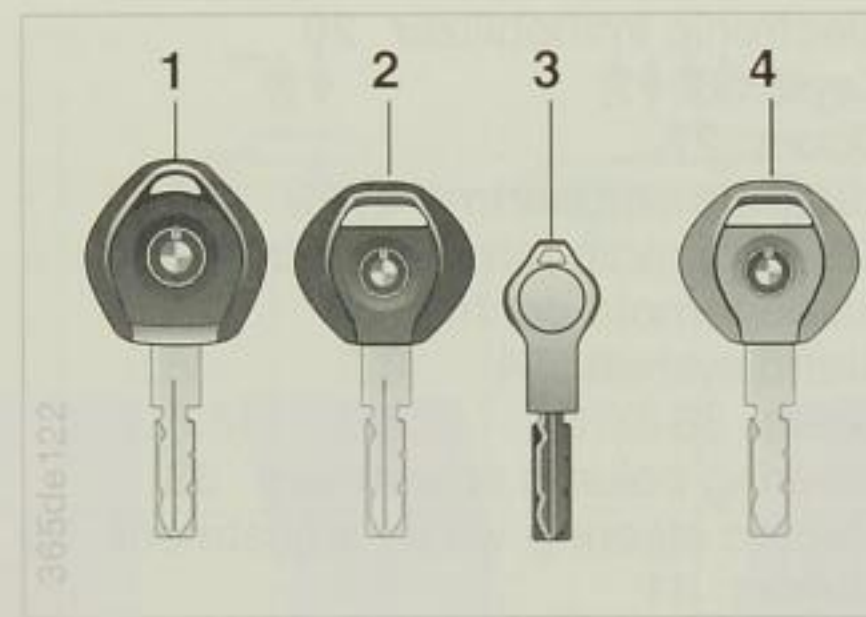

- 1 Master key with battery light (switched on by pressing the BMW badge)
- 2 Master key without light
- 3 Spare key to keep in a safe place, e.g. in a purse or wallet. This is a master key, but is not intended for regular use.
- 4 Key for doors and ignition This key does not operate the luggage compartment or glove box lock. It is useful at a hotel, for example.

Doors

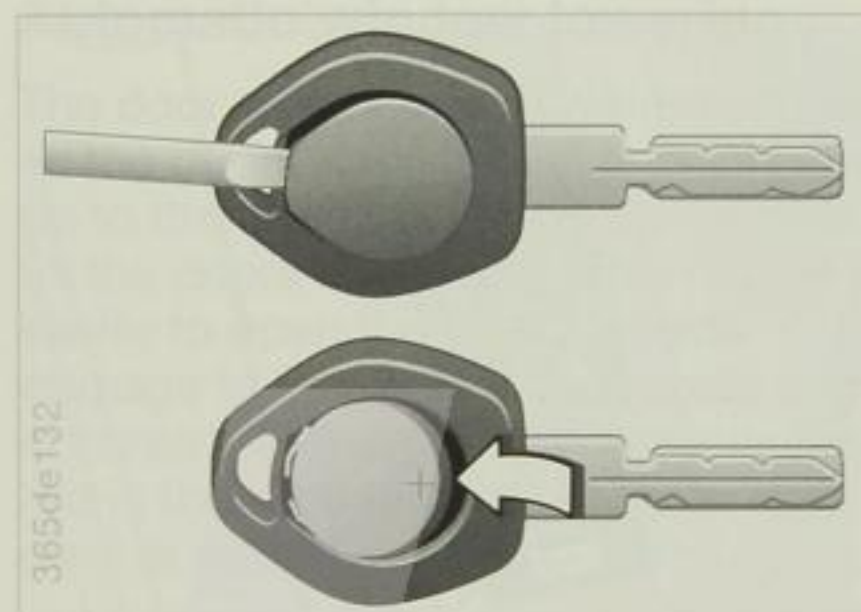

Master key with battery light

Renew the battery if the light becomes dim, or else battery acid may begin to leak.

To renew the battery, take off the cover on the back of the key with the aid of a screwdriver.

Insert a new battery of the same type (CR 2025) as illustrated, so that it touches the contacts correctly.

Place the cover back in position and press it down.



Return discarded batteries to a collecting point for used batteries or to your BMW Service station. ◀

Doors

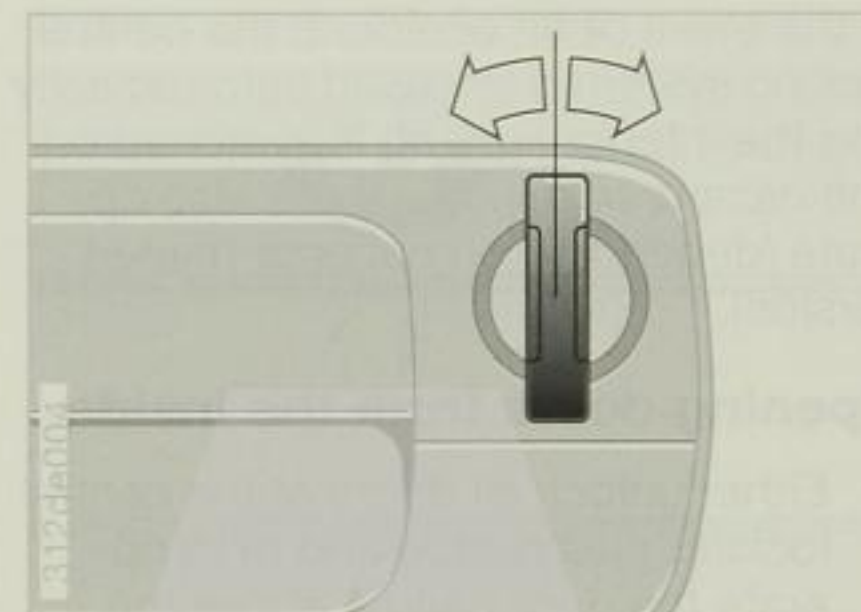

Central locking from the outside

When the doors, luggage compartment and fuel filler flap are closed they can be locked and unlocked with a key at a door lock.

The deadlocks are engaged at the same time. This prevents the doors from being unlocked by means of the safety lock buttons or door handles.

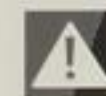

Do not lock the car with a key or with the remote control* if anyone is to remain inside it, since the car cannot then be unlocked from the inside. ◀

If your car has an alarm system*, this is also activated and de-activated when the key is turned in the door lock.

For further details on the alarm system, see page 34.

Convenient opening/closure of electric windows and sunroof at door lock

To open: when the door is closed, turn the key in the door lock to the "release" position and hold it there.

To close: when the door is closed, turn the key to the "locking" position and hold it there.

Release the key to halt the movement.

Emergency operation

(in the event of an electrical malfunction)

When the key is turned to the limit of its travel in the door lock, the door can be locked or unlocked.

Operating the central locking system from the inside

If the safety button on a door is operated, the doors and luggage compartment only are locked or unlocked, but the deadlocks are not operated.



If the car is locked from the inside at one of the safety buttons, the fuel filler flap remains unlocked, so that the car can be refuelled. ◀

Unlocking from the inside is also possible if one of the door handles is pulled.

To avoid being accidentally locked out of the car

- ▷ the car cannot be locked with the lock button if the driver's door is open.
- ▷ the lock button on the passenger's door only operates the central locking system if both doors are closed.



Note that children could lock the doors from the inside if they are alone in the car. Always take the key with you so that the car can be unlocked from the outside. ◀

In the event of an accident, the central locking system is released automatically and the interior lighting is switched on. The hazard warning flashers also operate (depending on national-market version).

Opening doors from the inside

- ▷ Either unlock all doors at the central locking pushbutton and then operate the door handle above the armrest or
- ▷ Pull the door handle twice (the first time to unlock the door, the second time to open it).

Opening doors from the outside

Raise the flap handle.

**Central locking system pushbutton**

This pushbutton also operates the central locking system when the driver's door is closed.

Automatic window lowering

The door windows are lowered slightly as the doors are opened, and run back up to the fully closed position as soon as the doors are closed. This makes it easier to open the doors, avoids damage to the rubber door seals and ensures that the glass is correctly located in the rubber door seal when the door is closed.

Driver's door lock heating

Raise the driver's door handle: the heating is switched on. The heating time is regulated automatically to reduce electric power consumption.

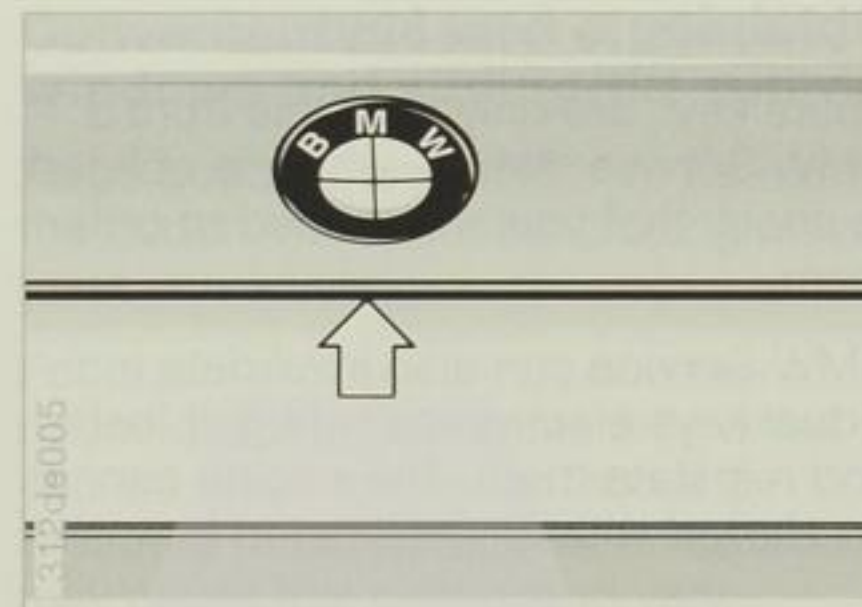
**Opening**

- ▷ Release by the way of the central locking system at a door lock or the lock on the glove box.
- ▷ Press the button under the BMW badge.

Manual operation in the event of a fault: see page 117.

Closing

- ▷ Shut the luggage compartment lid.
- ▷ Lock by the way of the central locking system at a door lock or the lock on the glove box.

Nobody can gain access to the contents of the luggage compartment if the glove box is locked, even if the door and ignition key is handed over to another per-

son.— This is important at a hotel, for instance.

Luggage compartment light

This light comes on when the lid is opened.

There are lashing points on the floor and rear wall of the luggage compartment for fitting luggage nets or tensioning straps to secure items of luggage*.



The luggage compartment lid should always be kept closed while the car is moving to prevent exhaust fumes from entering the car. If, in exceptional circumstances, it is necessary to travel with the luggage compartment lid opened, close all windows and the sliding/tilt roof and select a high airflow setting at the airflow volume selector of the automatic air conditioning system. ◀

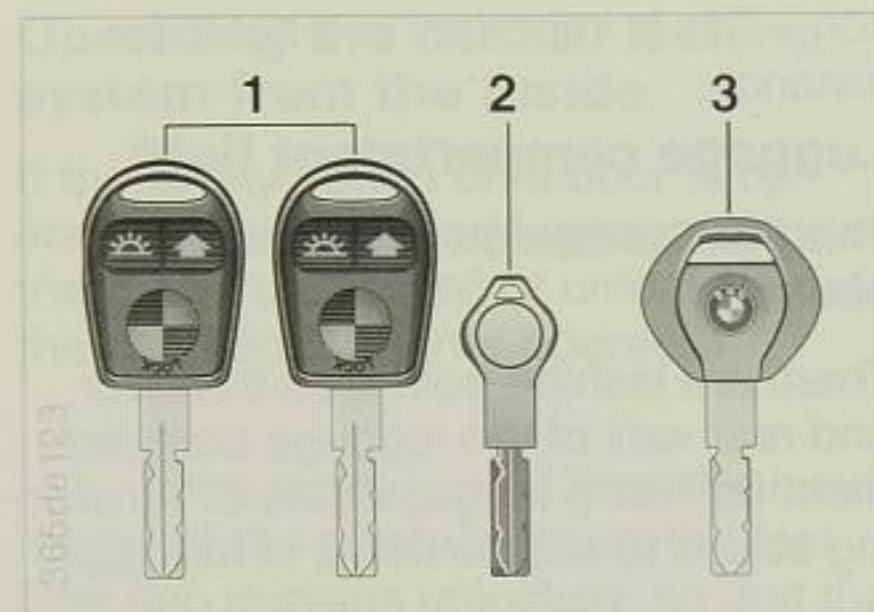

- 1 Master key with remote control transmitter
- 2 Spare key to keep in a safe place, e.g. in a purse or wallet. This is a master key, but is not intended for regular use.
- 3 Key for doors and ignition
This key does not operate the luggage compartment or glove box lock. This can be useful at a hotel, for example.

The passenger's door has no outside lock, as an additional precaution against theft. The safety button on the passenger's door does not operate the central locking system.

Obtaining a new key:

Spare keys are only available from a BMW Service station, which is obliged to check that you are entitled to order them.

BMW Service can also invalidate individual keys electronically (e.g. if lost) and reinstate them. The engine cannot be started with an invalidated key.



Unlocking

Press button 1.

The deadlocks are released at the same time, the alarm system* de-activated and the interior light switched on.



On certain national-market versions of the car, only the driver's door is unlocked the first time the button is pressed; remaining locks controlled by central locking system are released the second time the button is pressed. ◀

Convenient opening of electric windows and sliding/tilt sunroof

Press button 1 and hold it in. Releasing the button interrupts the opening movement immediately.

Locking and deadlocking

Press button 2.

The deadlocks are engaged and the alarm system activated at the same time.



Do not lock the car in this way if anyone is to remain inside, as the doors cannot then be opened from the inside. ◀

Convenient closure of electric windows and sliding/tilt sunroof

Press button 2 and hold it in. Releasing the button interrupts the closing movement immediately.

For reasons of security, convenient opening/closure operates only when you are close to the car (about 2 metres/6 ft away). External influences may cause this distance to vary.



During the closing process, check that there is no danger of fingers etc. being trapped. Releasing the button interrupts the closing movement immediately. ◀



Cars with alarm system: If the convenient closing movement is interrupted, the car must be unlocked again by pressing button 1 before the convenient closure process can be continued. Failing this, the tilt sensor and radio interior protection facilities will be out of action. ◀

Switching on the interior light

If the car is locked, press button 2. This function enables you – provided that the car is within the radio remote control's reception range – to locate your car by switching on the interior light, for instance on a parking lot.

Switching off tilt sensor

After locking the car, press button 2 again briefly. This also switches off the radio interior protection system of the alarm system (see page 34).

Master keys

The keys with remote-control transmitter are master keys.

Apart from the "Switching on interior light" function, the conventional keys perform the same functions as the remote control when inserted and turned in the lock.



On certain national-market versions, the alarm system* can only be operated with the remote control. If such cars are unlocked manually with the master key, the alarm will be triggered.

Pressing button 1 (unlocking) or starting the engine will switch off the alarm. If you have any queries, your BMW Service station will be glad to advise you. ◀

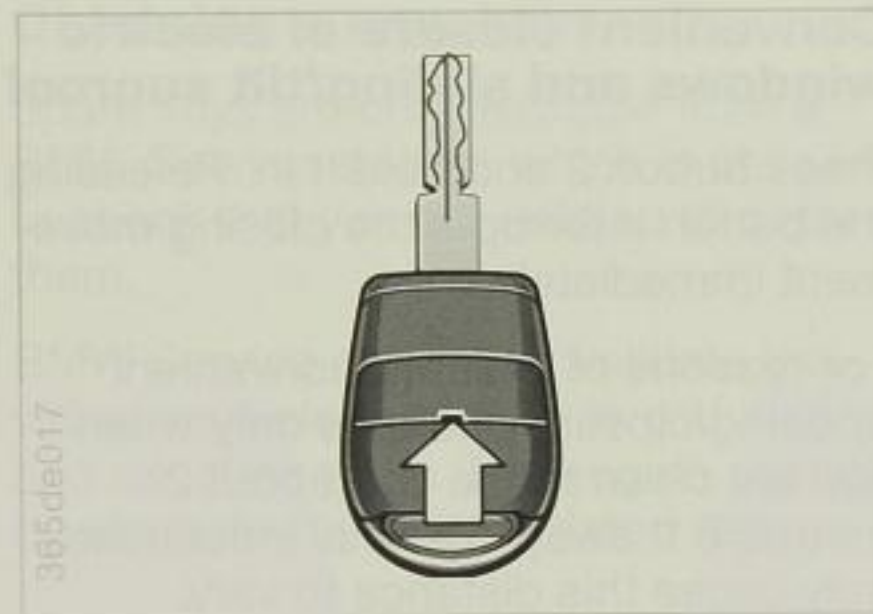

Note that children could lock the doors from the inside if they are alone in the car. Always take the key with you so that the car can be unlocked from the outside. ◀

**Batteries**

Renew the batteries when locking is no longer possible with the aid of the remote control:

- 1 Open the car with the remote control.
- 2 Lever off the cover by inserting a screwdriver blade at the cutout (arrow).



If the battery change takes less than one minute and none of the buttons is pressed, the transmitter does not need to be initialized. ◀

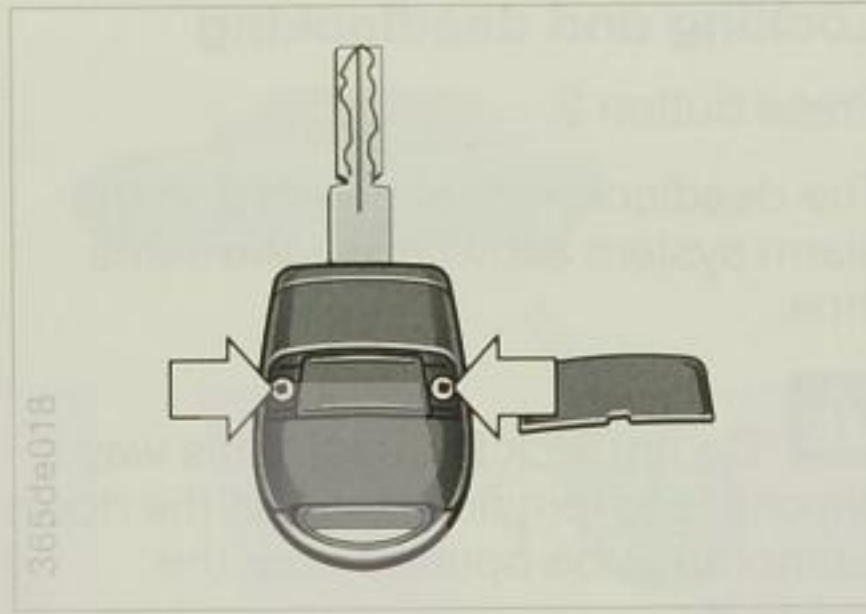

- 3 Loosen the two screws (arrows) and take off the cover. The battery type and the correct installed position are marked on the base of the battery compartment.

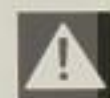

Use only batteries of the stated type (CR 1220). Make sure that the batteries are inserted correctly. ◀

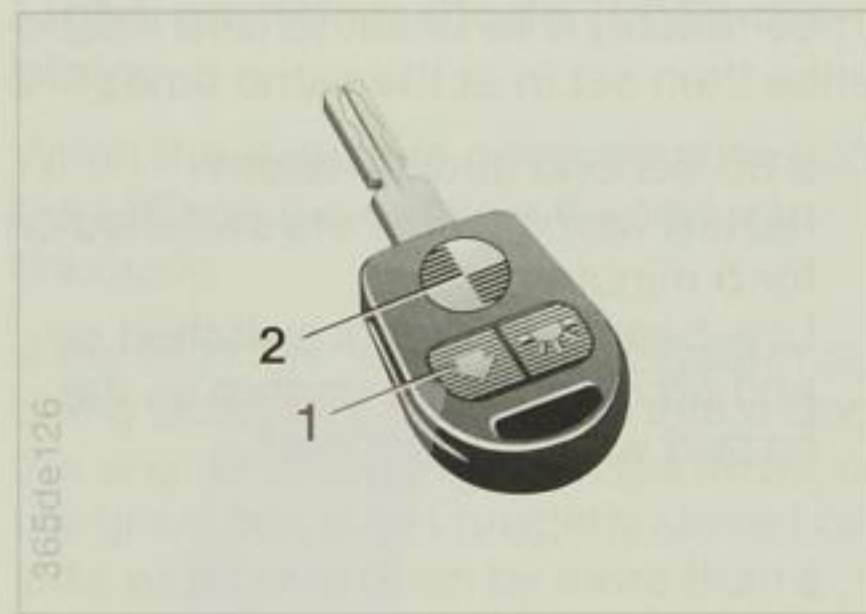

Return discarded batteries to a collecting point for used batteries or to your BMW Service station. ◀

**Initializing the remote control**

Whenever a battery is changed, the remote-control transmitter must be initialized again (unless the battery change took less than one minute and none of the buttons was pressed). The same procedure must be followed if a new transmitter is brought into use (for example, to replace a lost or defective one):

- 1 The driver's door must have been opened with the remote control.



If the car was not opened with the remote control, an interlock takes effect and initialization is not possible for 15 minutes.

- 2 Enter the car and close the driver's door.
- 3 Turn the ignition key briefly (for not more than 5 seconds) to position 1, then back to position 0.
- 4 Press button 1 on the remote control (see illustration) and hold it down. Press button 2 briefly three times in succession within 10 seconds, while button 1 is held down.
- 5 Release button 1.
- 6 The central locking system indicates that initialization has been performed successfully by closing and releasing the locks in rapid succession.

If the central locking system does not respond as described, repeat the initialization routine.

If you use additional remote-control transmitters (up to four) for the same car, the next initialization must begin within the next 30 seconds (repeat steps 4 to 6), otherwise they will be deactivated.

In the event of faults, contact your BMW Service station, which can also supply replacements.



Prevent unauthorised use of the radio remote control transmitter, for instance by handing only door and ignition key 3 or the spare key to hotel staff. ◀

Identical frequencies

The radio remote control may be susceptible to local interference from other systems or equipment operating on the same frequency.

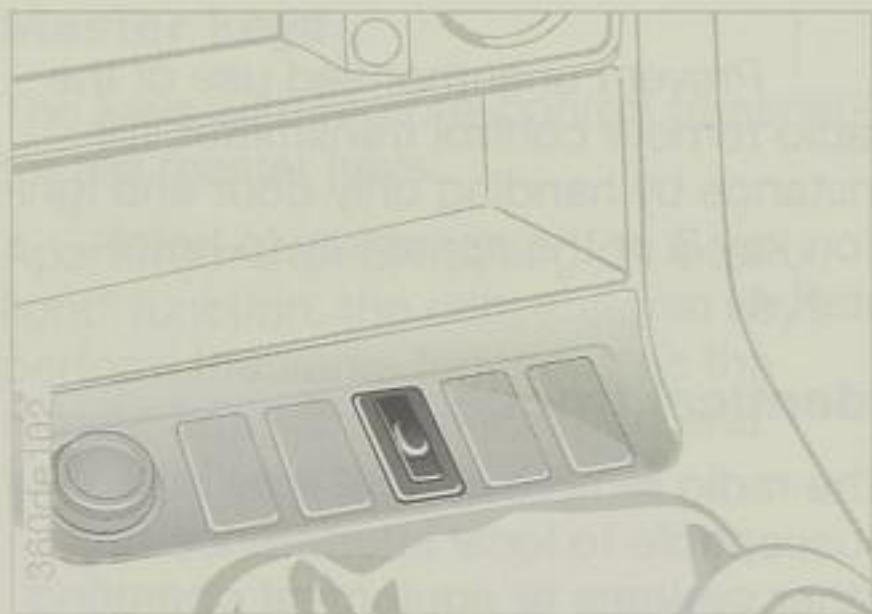

Cars with remote control

On some national-market versions, the alarm system can only be operated from the remote control.

If such cars are unlocked manually with the master key, the alarm will be triggered.

Pressing button 1 (unlocking) or starting the engine will switch off the alarm.

If you have any queries, your BMW Service station will be glad to advise you.

Activating and de-activating

The system is activated and de-activated only when the door lock is operated or, on cars with remote control, only when this is operated.

Activation is confirmed by the hazard warning flashers lighting up once only.

The alarm system reacts if:

- ▷ a door, the engine compartment or the luggage compartment is opened
- ▷ there is any movement inside the car (radio interior protection)
- ▷ the tilt angle of the car is changed, for instance if it is towed away or jacked up in order to remove the wheels
- ▷ the power supply from the battery is interrupted.

Three reactions to unauthorised interference then set in at the same time:

- ▷ a 30-second audible alarm
- ▷ hazard warning flashers switched on for 5 minutes*
- ▷ Low beam headlights switched on and off in the same rhythm as the hazard warning flashers*.

Alarm system*

Light-emitting diode (LED) displays

When the system is correctly activated, the LED on the console flashes continuously.

If the LED flashes when the system is being activated, this means that a door, the engine or luggage compartment or the glove box is not properly closed or a side window is open by more than a very small amount (approx. 10mm). Even if this situation remains uncorrected, the remaining (closed) items will be protected after 10 seconds and the LED will cease to flash and remain on.

When the system is de-activated, the LED goes out.

After the alarm has been triggered, the LED remains on. During de-activation, the LED flashes for 10 seconds as a sign that an attempt was made to tamper with the car.

The luggage compartment is also accessible when the system has been activated – except on cars with remote control. If the LED flashes fairly rapidly (10-second intervals), this indicates that the luggage compartment lid was closed but not locked (key turned to

right and removed).

To prevent an unwanted alarm signal being set off by the tilt detector, for example when the car is carried on a train or parked in elevating garages, this part of the system can be put out of action temporarily:

Immediately after activating the alarm system, repeat the activating procedure (in other words, turn the key to the locking position or press the remote control button a second time).

The LED will come on for a short time, then flash continuously. The tilt alarm sensor is then out of action until the entire system has been de-activated.



The convenient closure facility for windows and sliding/tilt roof, operated by means of the alarm function should, if possible, be operated without interruption: if the procedure is broken off and restarted within the first 10 seconds, this will shut down the tilt alarm sensor and the radio interior protection unintentionally. If this happens, de-activate and re-activate the system; the tilt alarm sensor and interior movement monitor will then operate correctly. ◀

If normal de-activation is not possible, adopt the following procedure:

- ▷ Open the door with a key (the alarm will sound for 30 seconds).
- ▷ Get into the car, close the door and turn the ignition key to position 1 (the alarm will again sound for 30 seconds).
- ▷ Wait until the LED goes out (after approx. 15 minutes). During this time, do not open any door and leave the ignition key in position 1.

The system is then de-activated and should be examined if necessary by a BMW Service station.

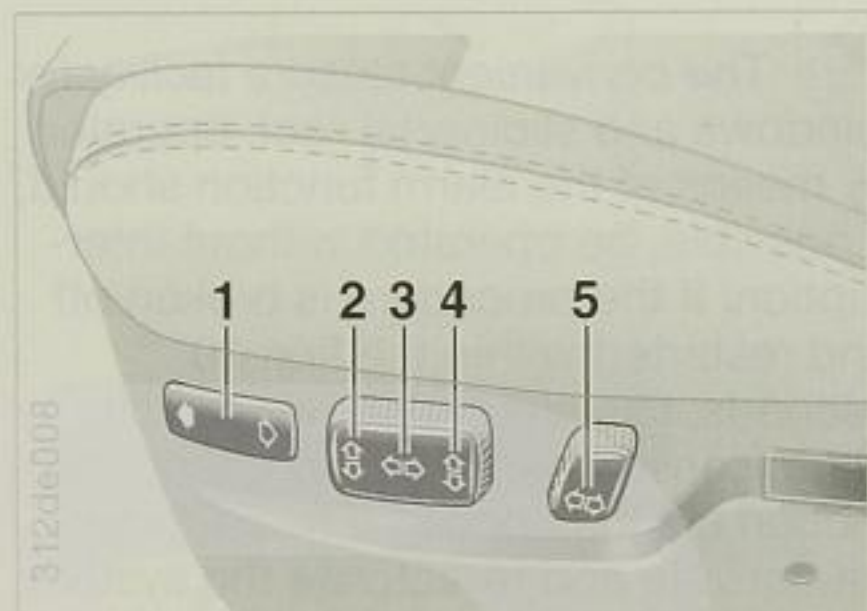

Electric seat adjustment

- 1 Rocker switch for thigh support adjustment (BMW sport seat only)

To adjust, move switch in direction of arrow:

- 2 Seat angle adjustment*
- 3 Forward/back movement
- 4 Seat height adjustment
- 5 Seat back angle adjustment

Head restraints

These are automatically adjusted in height whenever the seat height or backrest is repositioned.

Their angle can be adjusted manually.



The spine obtains most relief when you sit fully back in the seat and rest against the seat back. The ideal position is when the head is a straight-line extension of the spinal column.

On a long journey, the seat back can be inclined slightly more, to reduce muscular strain. You should still be able to reach the highest point on the steering wheel with the arms slightly bent. ◀



Do not reposition the driver's seat while the car is in motion. A sudden seat movement could cause you to lose control of the car and result in an accident.

During a journey, neither the driver's nor the front passenger's seat back should be reclined to an excessive angle.

Otherwise, in the event of an accident there is a risk that the seat occupant could "submarine" under the seat belt, which would then fail to exert its full protective action (see also safety instructions concerning "Seat belts"). Do not push the front seats rearwards if the car is standing on a slope (e.g. a garage entrance ramp or similar), or the automatic seat belt height adjusters could become disconnected. ◀

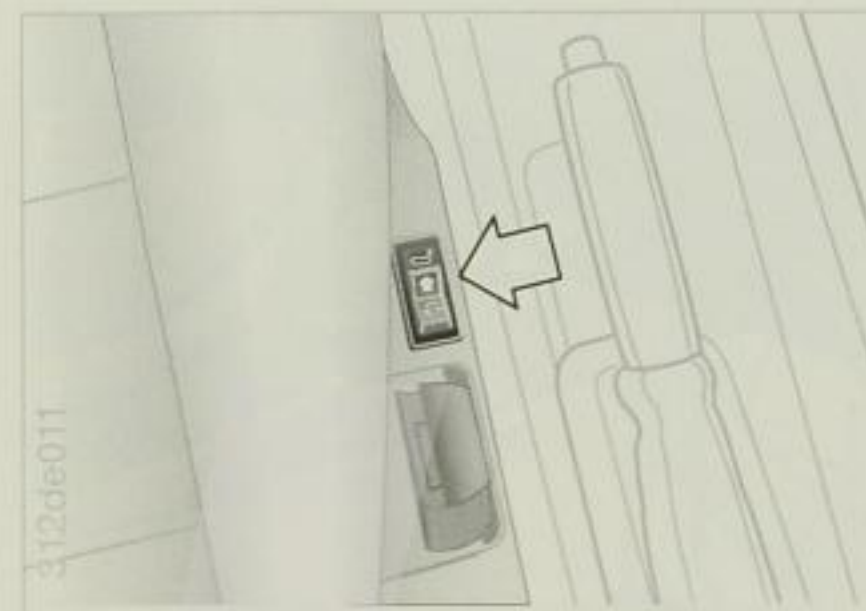

Lumbar support*

The seat back contour can be altered to provide more support to the curved (lumbar) section of the spine.

The upper edge of the pelvis and the spinal column are supported to encourage an upright but relaxed seated position.

Press the switch forwards to increase the curvature of the support.

Press the switch backwards to reduce the curvature of the support.

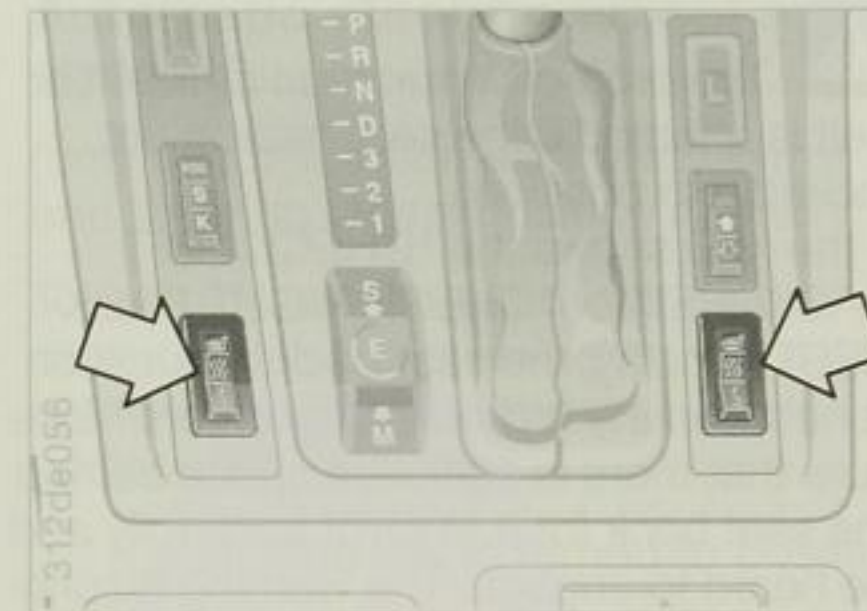

Seat heating

The seat base cushion and the seat back can be heated. The heating only operates when the engine is running.

Press the switches with the heating symbols:

⋈ Rapid heating while the symbol is illuminated. Automatic changeover to regular heating.

⋈ Regular heating. Cuts out automatically when the switch is no longer illuminated.

To switch over while heating: press the non-illuminated section of the switch.

To switch off prematurely: press the illuminated section of the switch.

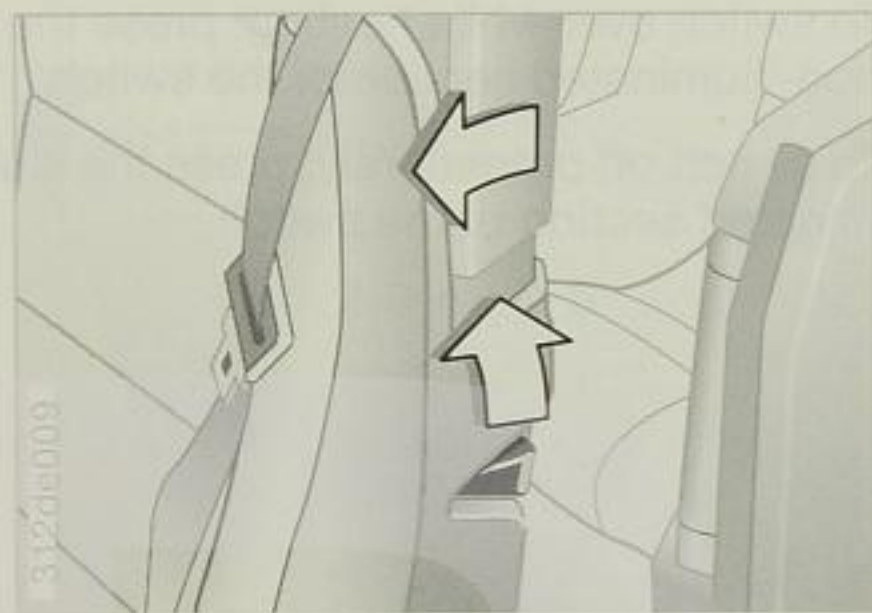
**Seat back release**

Press the lever up and pivot the seat back forwards.

! The protective function of the seat belt is affected if the seat back is not locked into position. If the MID shows the "CHECK LEFT BACKREST" or "CHECK RIGHT BACKREST" display, the seat back in question is not properly locked into position. Make sure that there is sufficient space behind the seat back for it to pivot back fully and be heard to engage. The warning display goes out as soon as the seat lock has engaged.

If the warning display does not go out, even though the seat back has engaged correctly, consult a BMW Service station. The car must not be driven with a seat occupied and the seat back not locked in position. ◀

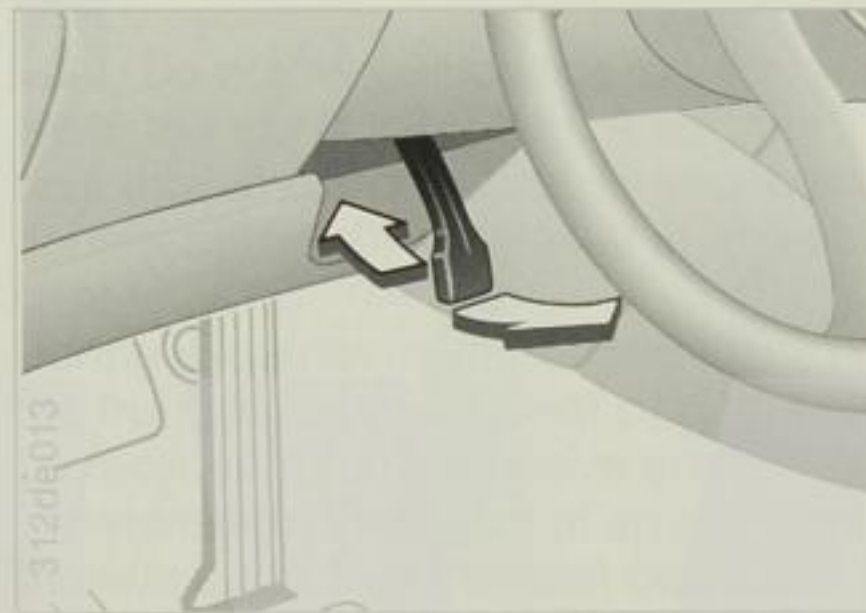
Steering col. adjustment

- ▷ Fold out the adjusting lever.
- ▷ Push or pull the steering wheel until the desired reach position is obtained.
- ▷ Fold the lever back in to clamp the steering column in the new position.

! Adjusting the position of the steering column while the car is being driven represents an accident risk. ◀

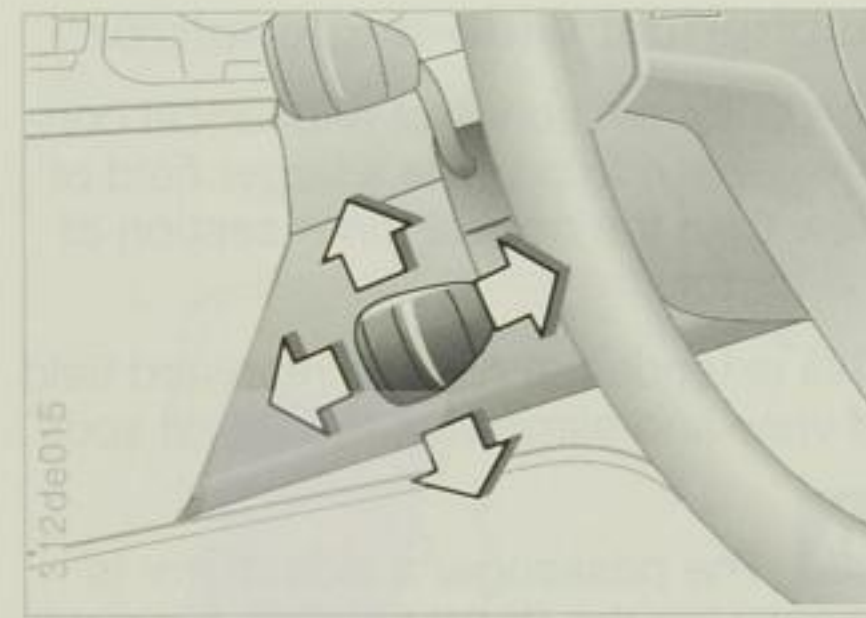
Electric steering column adjustment*

The steering wheel can be adjusted in four directions, which are simulated by the adjusting lever movements.

! Adjusting the position of the steering column while the car is being driven represents an accident risk. ◀

For memorizing the steering wheel position, see "Seat, mirror and steering wheel position memory," page 42.

Automatic steering wheel adjustment*

(only in conjunction with seat, mirror and steering wheel position memory)

To simplify entering and leaving the driver's seat, the steering moves automatically to its uppermost position when:

- ▷ the ignition key is turned to position 0
- ▷ the ignition key is in position 1 and the driver's door is opened
- ▷ the ignition key is in position 2, the handbrake is applied and the driver's door is opened.

The steering wheel returns to the driving (memorized) position when:

- ▷ the ignition key is in position 2 and the handbrake is released with the driver's door open
- ▷ the ignition key is in position 2, the handbrake is applied and the driver's door is closed.

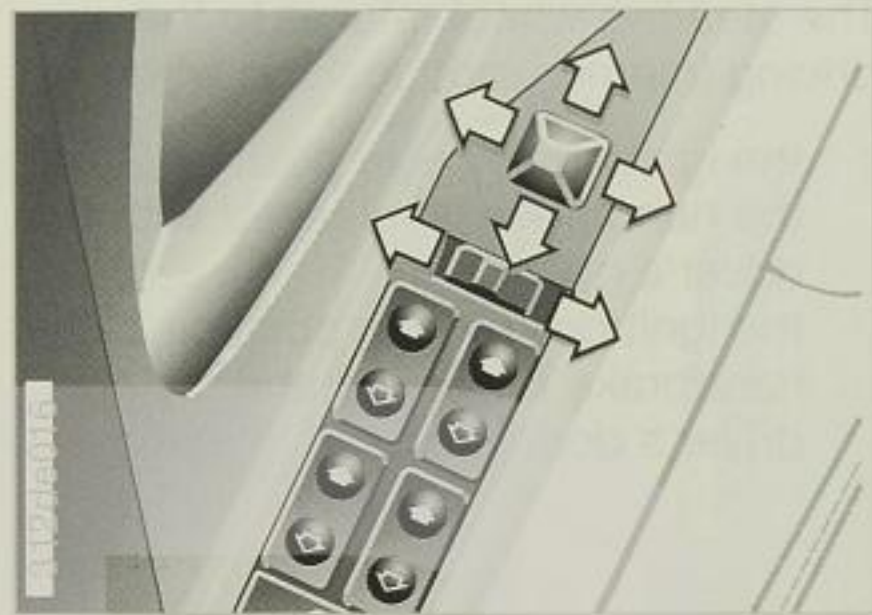

Electric exterior mirrors

These can be adjusted in four directions with the mirror control switch.

Changeover switch for the other mirror:

Move switch to left—for driver's mirror.

Move switch to right—for passenger's mirror.

The mirrors can also be adjusted manually by pressing the edge of the glass.

For memorizing mirror positions, see "Seat, mirror and steering wheel position memory," page 42.

Passenger's side mirror tilt-down (parking) position

(only with seat, mirror and steering wheel position memory)

Move the mirror changeover switch to the "Driver's side" position.

When reverse gear (or automatic transmission selector lever position R) is selected, the mirror on the passenger's side will tilt down slightly to display the ground along the side of the car (for instance the edge of the kerb).

This automatic function can be switched off if not required: move the mirror changeover switch to the "Passenger's side" position.

Aspherical wide-angle mirror*

The outer section is of aspherical convex pattern to provide a larger field of view than the normal inner section of the mirror.

This extends the driver's rearward field of view and eliminates the "blind spot".

 The passenger's side mirror is convex (on the BMW 850CSi, both exterior mirrors are convex), so that reflected objects are closer than they appear. It can be difficult to estimate the precise distance at which another vehicle is following your car. The same applies to the convex section of partly-convex aspherical wide-angle mirrors. ◀

Electric mirror heating

Both exterior mirrors are automatically heated (controlled heat output) in ignition key position 2.

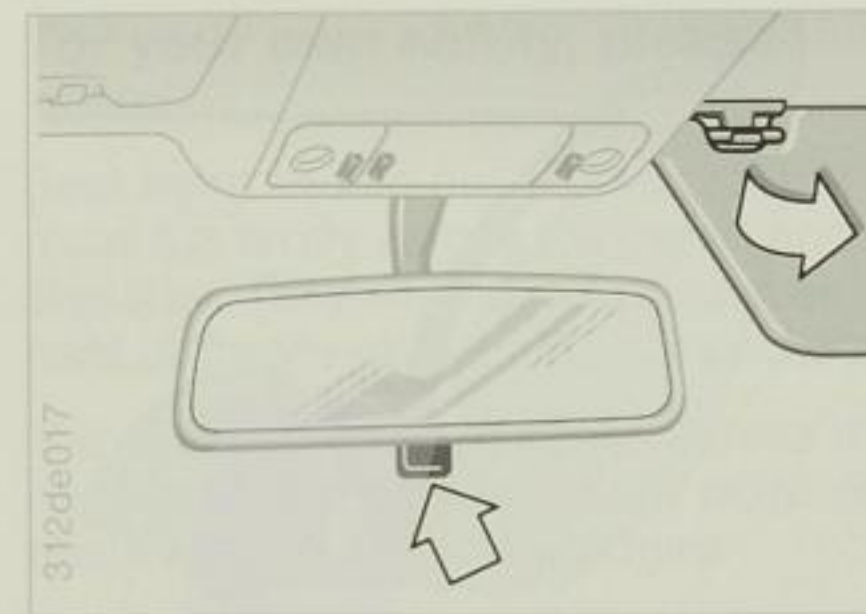

Interior mirror

To reduce glare from the headlights of following vehicles after dark, move the small lever to tilt the mirror.

Make-up mirrors

Fold the sun visor down and slide the mirror cover sideways.

The mirrors are illuminated when the exterior lights of the car are switched on.

Sun visors

The sun visors can also be pivoted to the side, against the door windows.

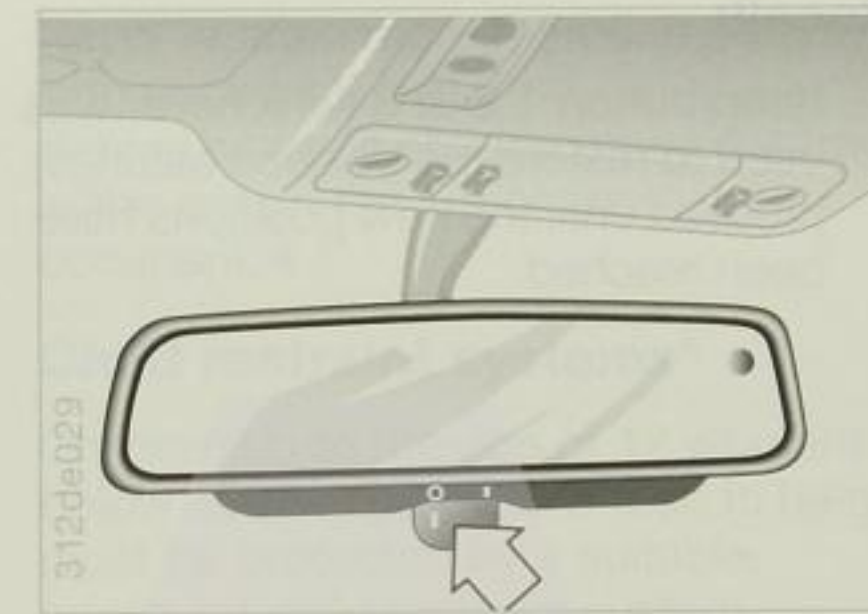

Automatic anti-glare interior mirror (electrochromic)*

Knob in position 0: automatic anti-glare function out of action.

Knob in position 1: the mirror dims automatically and continuously when light strikes it (from the surrounding area as well as headlights of other vehicles).

When reverse gear is selected, the mirror reverts from either position to the clear-glass (non-dimmed) setting.

 The mirror will not operate reliably unless the photo-electric cells are kept clean and are not obstructed. ◀

Non-automatic anti-glare interior mirror

(only in conjunction with infrared remote control)

Knob in position 0: normal mirror position.

Knob in position 1: anti-glare mirror position.

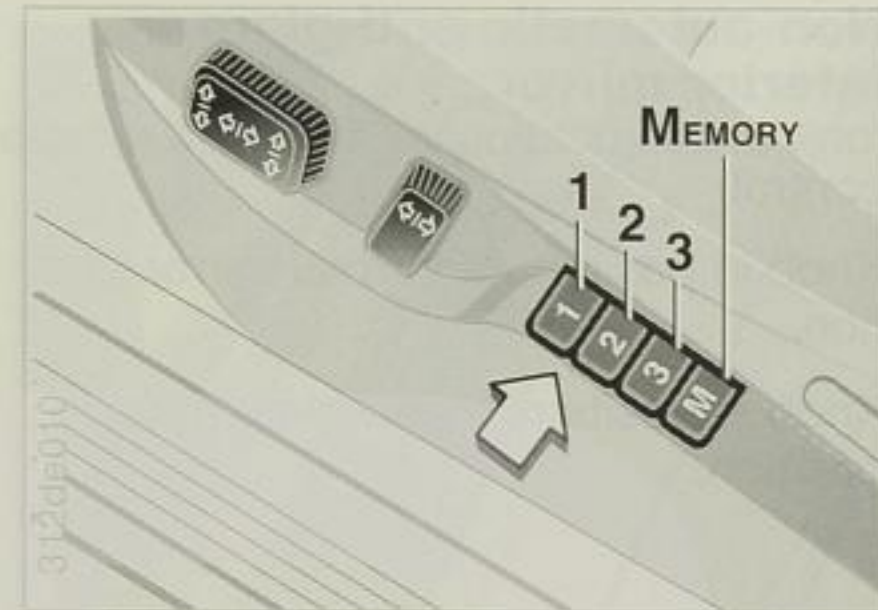

Three different seat, exterior mirror and (only with electric steering wheel adjustment) steering wheel positions can be memorized.

Memorizing:

- Ignition key must be in position 1 or 2.
- Select the desired seat, exterior mirror or steering wheel position.
- Press the MEMORY button: the tell-tale light in the button comes on.
- Press button 1, 2 or 3 as required in the direction of the arrow: the telltale light goes out.

Recall:

- Keep button 1, 2 or 3 (whichever was used to restore the position settings) pressed until the new positions have been reached.

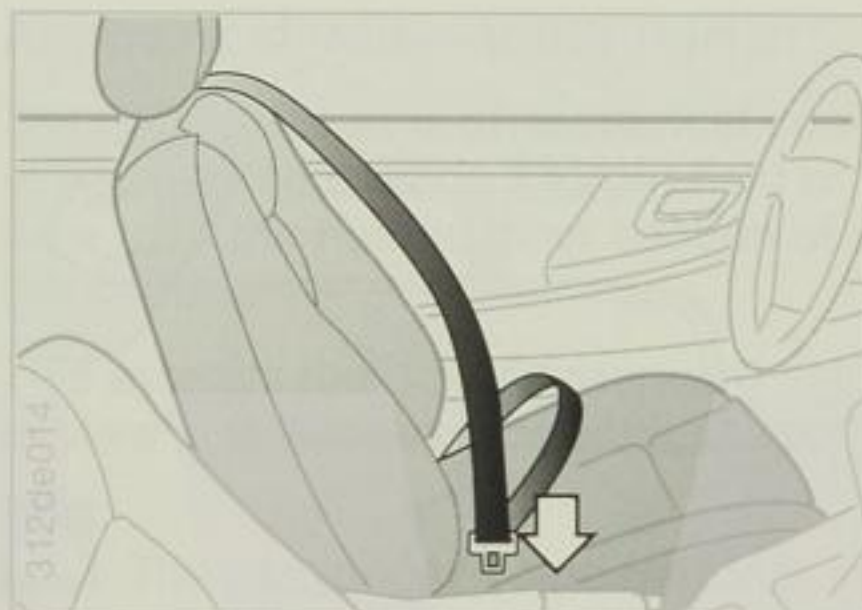

Wear the seat belts whenever the car is driven.

You do not have to adjust the front seat belt manually. The seat-integrated belt system resets itself automatically to accommodate wearers of different sizes.

Fastening the belt:

The seat belt catch must be heard to snap closed.

Releasing the belt:

Press the red release button on the belt catch and guide the belt back if necessary to reinforce the action of the automatic reel.

Seat belts

For your own safety, please note:

Seat belts should not be twisted and must run firmly across the pelvis and shoulder. They should not pass over hard or fragile objects in your pockets.

The seat belt must not pass across the neck, become trapped at any point or chafe against any sharp edges.

The belt should be as close to the body as possible; therefore avoid wearing thick and heavy clothing.

Take up slack regularly by pulling up the belt at the shoulder.



For the following reasons, it is essential for the belt not to be worn under no tension: in the event of a head-on collision, the lap belt could otherwise slide over the hips and injure the lower part of the body. Furthermore, excessive belt slack delays the restraining action. Pregnant women are also advised to wear the seat belt at all times, making sure that the lap belt is low down over the hips and does not press against the abdomen.

Never restrain more than one person with each seat belt. Babies or small children must not travel in the car on the lap of another occupant. ◀

Child restraint systems*

Children up to the age of 12 who are below 150 cm (approx. 5 feet) in height must be protected by a suitable, approved child restraint system.

Babies up to 18 months can travel on the rear seat in a suitable cot or shell facing rearwards and retained by the standard seat belts.

BMW Service can supply suitable child restraint systems for the various age groups.



Child restraint systems are not to be attached to the front passenger seat. ◀

So that child restraint systems can be restrained safely by the seat belt, your BMW has an automatic-reel mechanism which can be locked in the required position.

Pull out the belt fully. Allow it to retract until the child restraint system is held securely.

After the belt has been released and allowed to retract fully, its normal automatic function will be restored.

Under no circumstances are seat-belt or child restraint systems to be modified.

The seat belt reel will lock:

- ▷ if pulled out rapidly,
- ▷ during sudden braking or accelerating,
- ▷ when the car is cornered sharply,
- ▷ when the car is tilted at a considerable angle.



Drivers should ensure that their passengers also comply with the relevant requirements and instructions concerning seat belts. ◀

For care of belts, see page 143.

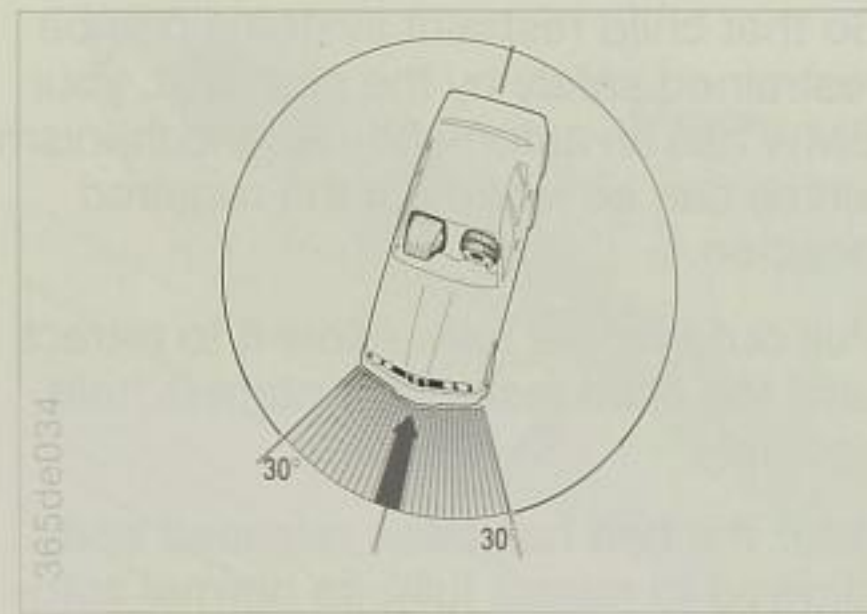

- ▷ Driver's airbag*
- ▷ Front passenger's airbag*

The airbag restraint systems protect the driver/front passenger in a severe head-on collision. The inflated airbag restrains forward movement of the seat occupant and protects his or her head and upper body against injury.

The picture shows the area within which the airbag restraint system is triggered.

In less severe accidents and if the car rolls over, is sideswiped or struck from the rear, protection is provided by the seat belt alone.

 The airbag is an additional safety device. It must not be regarded as an alternative to wearing the seat belt. ◀

Telltale light in instrument cluster:

This telltale confirms that the system is in working order when the ignition key is turned to position 1 or beyond.

System operational:

- ▷ The telltale comes on for about 6 seconds or 2 seconds* and then goes out.

System defective:

- ▷ The telltale does not come on.
- ▷ The telltale comes on for about 6 seconds or 2 seconds* , goes out briefly and then comes on again.
- ▷ The telltale flashes for 5 minutes during a journey, then remains on permanently.
- ▷ The telltale remains on permanently* or flickers*.

In these cases there is a risk that the system will not be triggered even if a sufficiently severe accident occurs.

Please have it checked by a BMW Service station without delay.

 The airbag telltale light also comes on if the belt catch tensioner is triggered. ◀

What happens when the system is triggered?

The airbags, which are concealed under the flaps in the steering wheel or in the instrument panel, are inflated rapidly and burst out of the preformed aperture in the padded covers.

The entire process takes place with great force, within only a twentieth of a second.

In view of the very brief response time of the system, the noise of propellant ignition, inflation and subsequent deflation is lost in the general accident situation.

Propellant gas and small quantities of gaseous fumes are released when the airbag is triggered. They do not represent a health hazard or imply that the car has caught fire.

The sudden increase in pressure inside the car when airbags are inflated may temporarily impair the hearing of the occupants.

 Your seated position should be as far as convenient from the steering wheel or instrument panel. Always hold the steering wheel by its rim. Failure to drive in this manner could result in hand or arm injuries if the airbag operates. No objects should be held or allowed to rest between the airbag and the seat body of the occupant. Even if all the appropriate precautions are taken, the risk of instrument panel injuries when airbags are triggered cannot be entirely ruled out in all accident situations. ◀

Airbag safety instructions

The gas generator of the airbag restraint system gas must not be removed from the car. Any testing and assembly work on it must only be carried out by specially trained personnel. If the airbag restraint system develops a fault, is deactivated or is triggered as intended in an accident, the necessary repair or dismantling work must be entrusted to a BMW Service station.

No modifications to individual components or to the wiring should be attempted. This includes the padded cover in the centre of the steering wheel and the cover on the instrument panel, which must never be covered with adhesive or any other material or otherwise modified or reworked in any way. The steering wheel itself must not be taken off.

In order to comply with the relevant safety regulations, the airbag generator must only be scrapped by a BMW Service station.

Any careless or unskilled interference with the system could lead to its failure or to accidental triggering with the risk of injury.

Child restraint systems mounted on the front passenger's seat are not permitted on cars with a front-passenger airbag. In certain countries it is in any case required by law that children under the age of 12 should only travel on the rear seats.

 Drivers of cars fitted with airbags should ensure that their passengers also comply with the relevant requirements and instructions. ◀

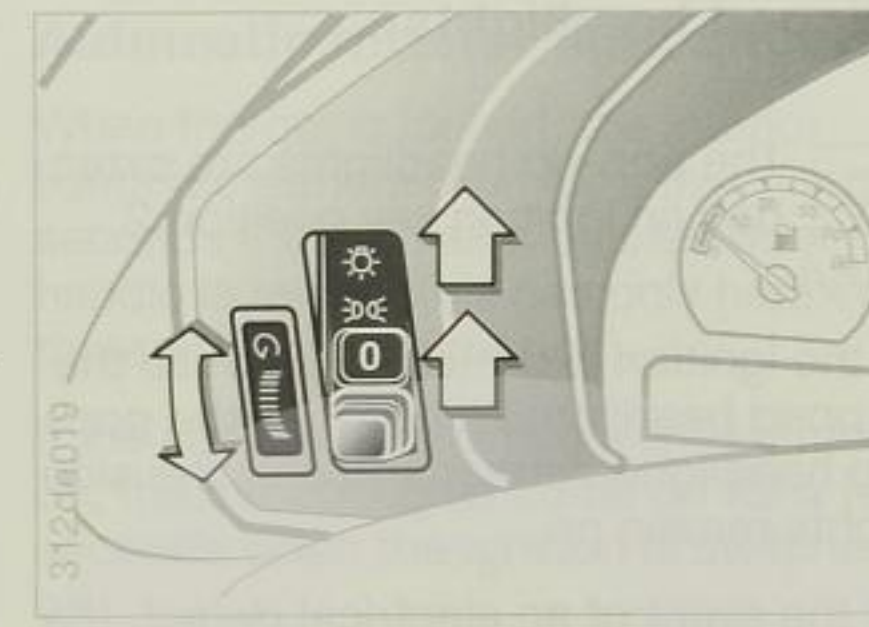

Daytime lights setting*

 If desired, the light switch can remain in this position: when the ignition is turned off, the car lights go out.

On vehicles fitted with the daytime lights setting*, the daytime lights come on automatically in ignition key position 2 even if this switch setting is not used, and if the light switch is at 0.

Side lights



Dipped headlights

 The pop-up headlights are extended (in ignition key position 2 only).

If the ignition is switched off while the dipped headlights are in use, the pop-up headlights retract and only the side lights remain on.

In the event of an electrical defect, the pop-up headlights can be extended or retracted manually. See page 117.

Instrument lighting

The intensity can be varied at the knurled wheel.

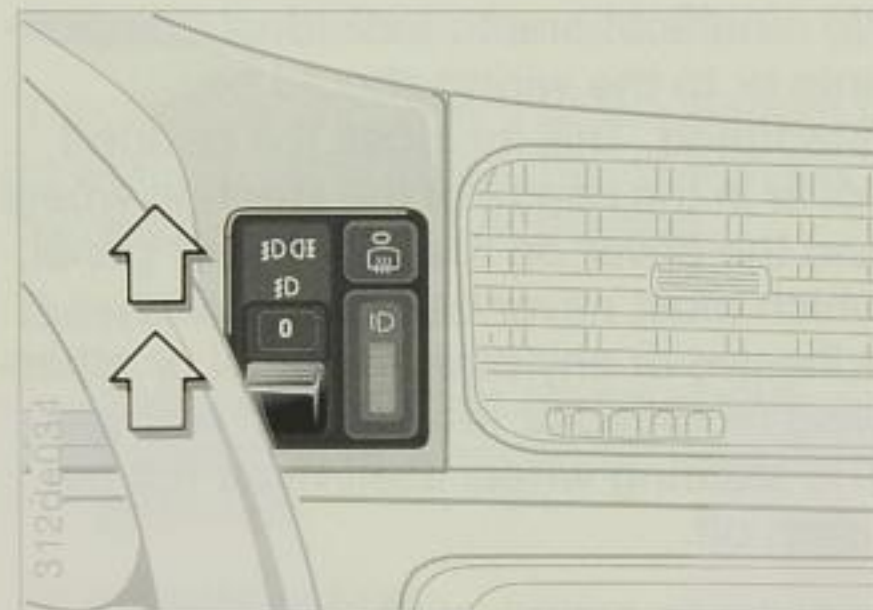
**Fog lights**

 The green telltale light on the instrument panel comes on when the fog lights are in use.

Front and rear fog lights

 The yellow telltale light on the instrument panel comes on additionally when the rear fog lights are in use.

Please comply with local legislation concerning the use of front and rear fog lights.

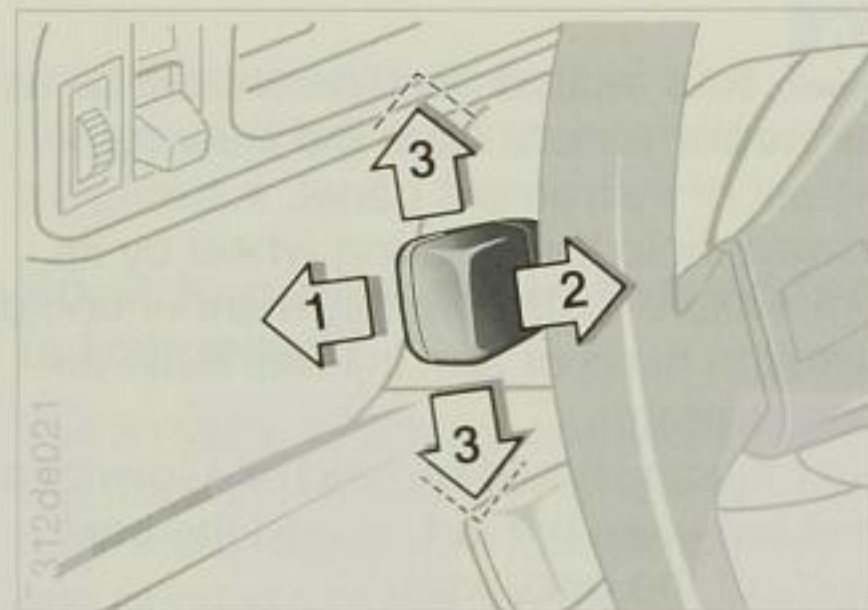

- 1 High beam headlights (blue telltale light)
- 2 Headlight flasher
- 3 Turn indicator repeater (green telltale light, flasher relay ticks rhythmically).

Repeater flashes and relay ticks more rapidly than usual: a turn indicator bulb has blown.

To indicate a turn briefly

Move the lever lightly, only as far as the first pressure point.

Right or left parking lights

When the steering lock is engaged, press the lever beyond the normal turn indicating position until it reaches a pressure point.

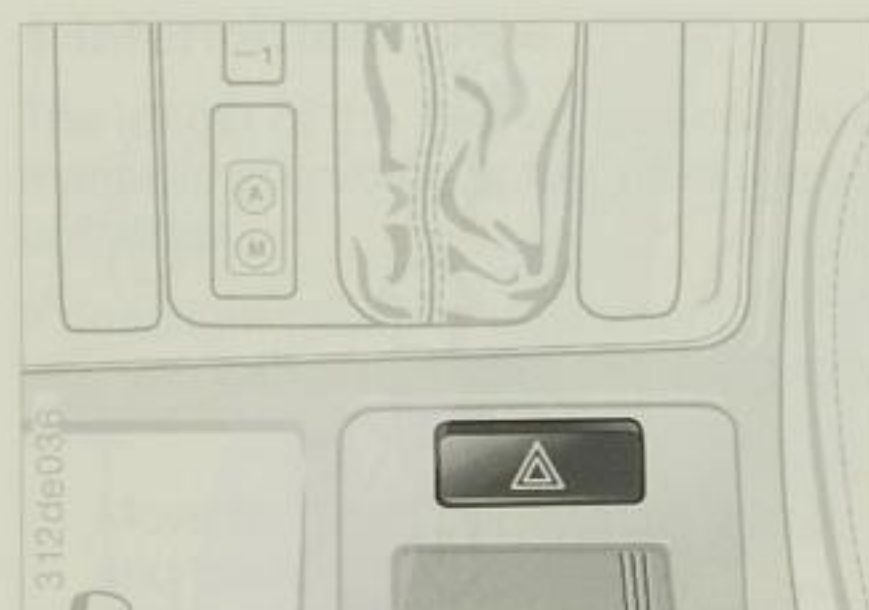

The pushbutton lights up in a regular rhythm when the hazard warning flashers are operating.

The pushbutton is illuminated when the exterior lights of the car are on.

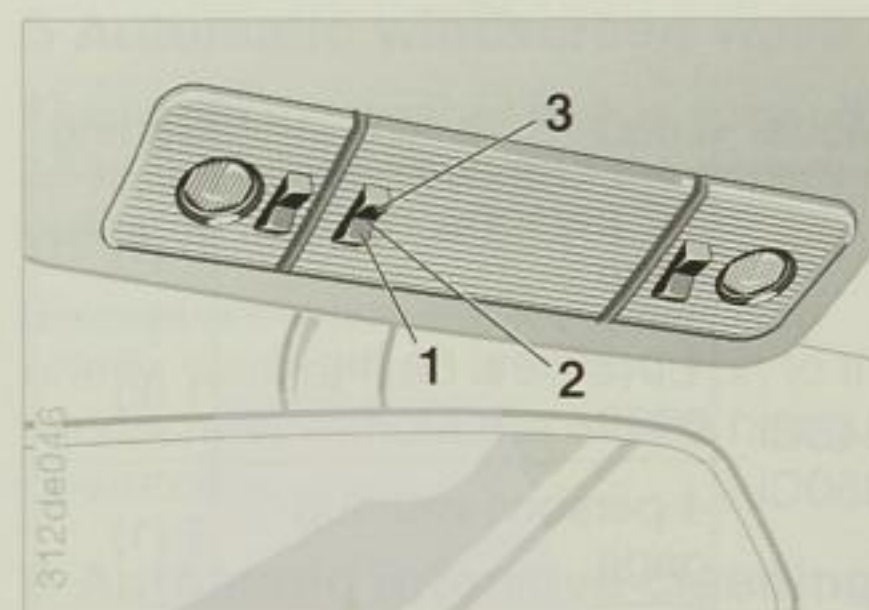

- 1 The lights come on
 - 2 Lights permanently off
 - 3 Light permanently on
- The reading lights next to the front interior light are wired similarly.

Automatic interior light circuit

When the car is locked, the interior lights are switched on for a few seconds if the driver's outside door handle is raised (this can only happen three times in succession).

If the car's outside lights were switched on, the interior lights come on for a few seconds when the ignition is switched off.

A safety circuit ensures that any lights still burning inside the car are extinguished about 15 minutes after the car has been locked and left parked.

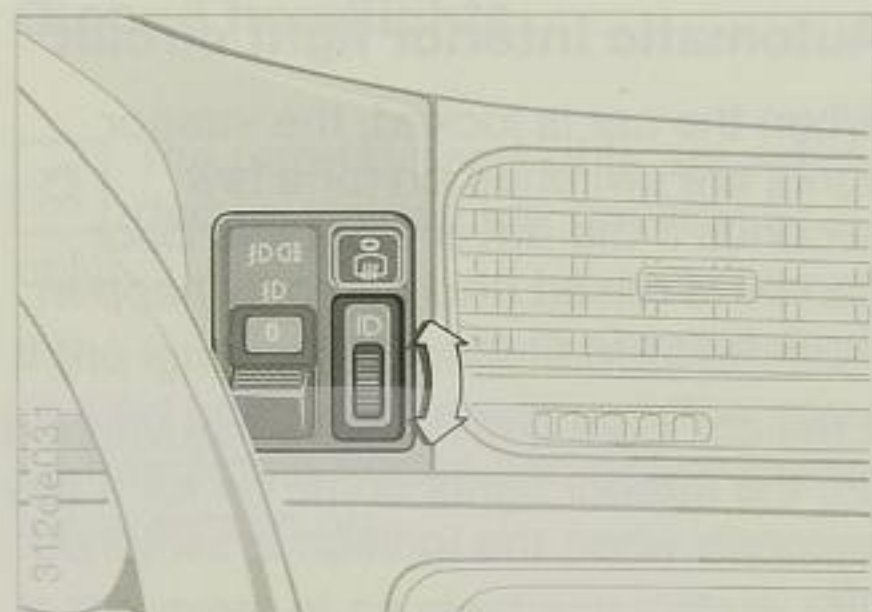

To avoid dazzling the drivers of oncoming vehicles, you must adjust the headlight beam throw to suit the load carried in the car. Position 0 is for passengers without luggage, and when not towing a trailer (with a trailer = position 1).

For further settings, see the table in the next column.

Model	Load	Setting
840Ci 850Ci	1-2 persons, no luggage	0 (1)
	4 persons, no luggage	1 (2)
	4 persons with luggage	1 (1)
	1 person, luggage compartment full	2 (2)
850CSi	1-2 persons, no luggage, or 4 persons, no luggage	0
	4 persons, no luggage or 1 person, luggage compartment full	1

Figures in brackets () apply when towing a trailer.

Note the permitted rear-axle load limit.

Wipe/wash equipment

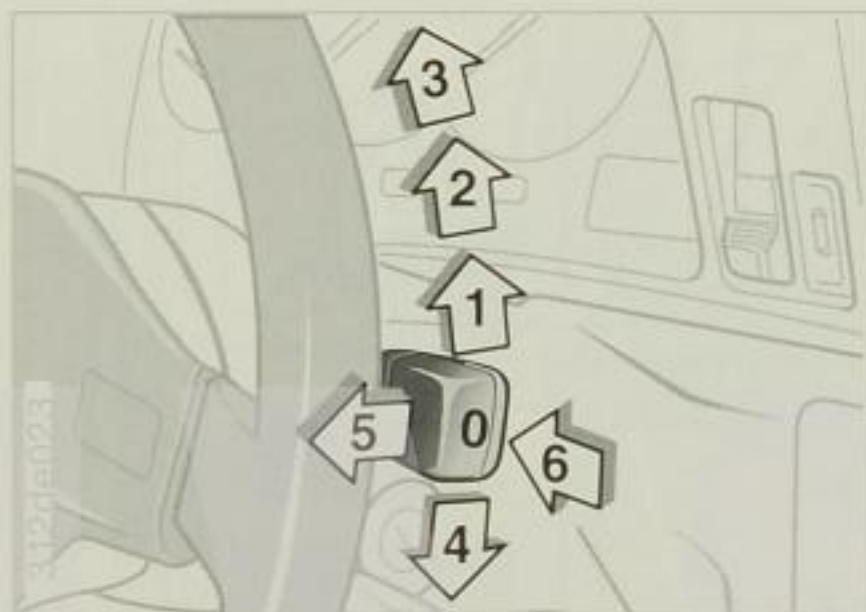

- 0 Parked position of wipers
- 1 Intermittent wipe
- 2 Normal wiper speed
- 3 Fast wiper speed
- 4 Flick wipe
- 5 Automatic windscreen wash
- 6 Automatic intensive cleaning

0 Parked wiper position

The wipers are partly concealed behind the rear edge of the engine compartment lid. In order to swing the wipers up vertically, for instance to renew the blades or at sub-zero temperatures, lever position 1 should be selected and the ignition switched off as soon as the wipers reach the new position.

Wipe/wash equipment

1 Intermittent wipe

The length of the interval is varied automatically according to actual road speed of the car.

If headlight cleaning equipment* is fitted, you can also influence the interval time:

- ▷ Move the lever briefly from 0 to 1 and back.
- ▷ The time which you allow to elapse before switching on again (from 0 to 1) is the subsequent intermittent-wipe interval (maximum 25 seconds).

This interval setting is cancelled if you return the lever to 0 or when the ignition is switched off.

2 Normal wiper speed

If the car comes to a standstill, the wipers automatically switch to intermittent operation.

3 Fast wiper speed

If the car comes to a standstill, the wipers switch to normal speed.

5 Automatic windscreen wash

Fluid from the washer tank is sprayed on to the windscreen and the wipers operated briefly.

(Exception: when the lever is pulled briefly, washer fluid is sprayed on to the windscreen without the wipers being operated.)

6 Automatic intensive cleaning

Same as 5, but intensive cleaning fluid is first sprayed on to the windscreen.

Headlight cleaning system*

When the headlights are switched on, they are automatically cleaned as well on each fifth occasion that the windscreen wiper or intensive cleaning system is operated.



Do not use the washer if there is any risk of the liquid freezing to the windscreen. This could interfere with the driver's view of the road. Do not run the washer if the fluid reservoir is empty, or else the washer pump will be damaged. ◀

Heating the windscreen washer jets

This takes place automatically in ignition key position 2.



These can be operated in ignition key position 2.

- ▷ Press in the rocker switch in until the pressure point is felt: The window will continue moving until the rocker switch is released.
- ▷ Press the rocker switch in briefly beyond the pressure point (one-touch function*): The window opens or shuts automatically. In this case, window movement is halted by touching the switch again briefly. The one-touch function applies to opening and closing the door windows, but only to opening the rear side windows.

There is a separate rocker switch on the passenger's side.

After the ignition has been switched off, the electric windows can still be operated

- ▷ in ignition key position 0 or
- ▷ with the key removed and also
- ▷ the first time the doors are opened.

Protective function

If a door window encounters an obstruction while closing at a point above approximately half the total vertical movement, the glass will come to a halt and then re-open slightly.

This protective function can be put out of action (for instance if the window moves stiffly in frosty weather) by holding down the one-touch function.

The system is also protected against overloads and malfunctions by an automatic electronic circuit breaker.

▶ If a door window is open when the car reaches a speed of approx. 150km/h, it will close automatically to keep the noise level low. However, if the window is then re-opened, this function is put out of action for this particular window until the engine is re-started .

After any power supply interruption, for

instance if the batteries are disconnected, the electric window functions must be re-activated: either close the windows completely or, if already closed, press the corresponding switch once briefly. ◀

Convenient operation of windows at door lock

To open: with the door closed, turn the key to the "open" position and hold it there.

To close: with the door closed, turn the key to the "close" position and hold it there.

Release the key to halt the movement.

For convenient operation of windows by means of the remote control, see page 30.

⚠ Careless and unsupervised closure of the windows could cause injury. Make quite sure that children cannot operate the switches accidentally. Always remove the ignition key and take it with you when leaving the car. ◀

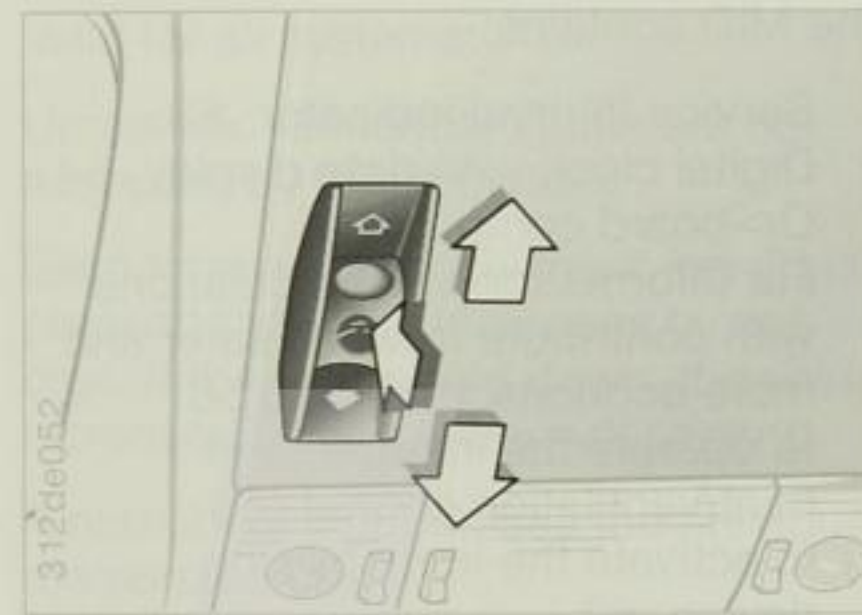

⚠ Can be operated in ignition key position 2.

To raise: press the switch.

To open: slide switch to the rear.

To close: slide switch forwards.

▶ When raised, the roof lining moves back only a short distance. ◀

One-touch function*

Sunroof opens or closes automatically if the switch is moved once in the desired direction. Movement is stopped by touching the switch again. The one-touch function cannot close the roof from the raised position.

After the ignition has been switched off, the electric windows can still be operated

- ▷ in ignition key positions 1 and 0 or
- ▷ with the key removed and also
- ▷ if the doors are opened once only.

Protective function

If the sunroof panel, when operated by the one-touch function or from a door lock, encounters an obstruction after it has closed about halfway, it will come to a halt and re-open slightly.

After an interruption to the power supply (for example if the batteries are disconnected), the protective function must be re-activated by pressing the switch or sliding it forward and holding it in position until the sunroof panel is fully raised.

If an electrical defect occurs, the sunroof can be operated manually. See page 117.

An electronic automatic circuit breaker protects the system against overloads and malfunctions.

Convenient operation of the sunroof from the doorlock

To open: with the door closed, turn the

key to the "deadlock" position and hold it there.

To close: with the door closed, turn the key to the "Engage central locking system" or "Engage deadlock" position and hold it there.

Release the key to halt the movement.

For convenient closure/opening of the sunroof by means of the remote control, see page 30)

⚠ Careless or unsupervised closure of the sunroof could cause injury. Make quite sure that children cannot operate the switches accidentally. Always remove the ignition key and take it with you when leaving the car. ◀

▶ To prevent low air pressure or draughts inside the car when the sliding/tilt roof is slid back and in particular when it is tilted up, keep the air outlets of the ventilation system open and boost the airflow through them if necessary. ◀

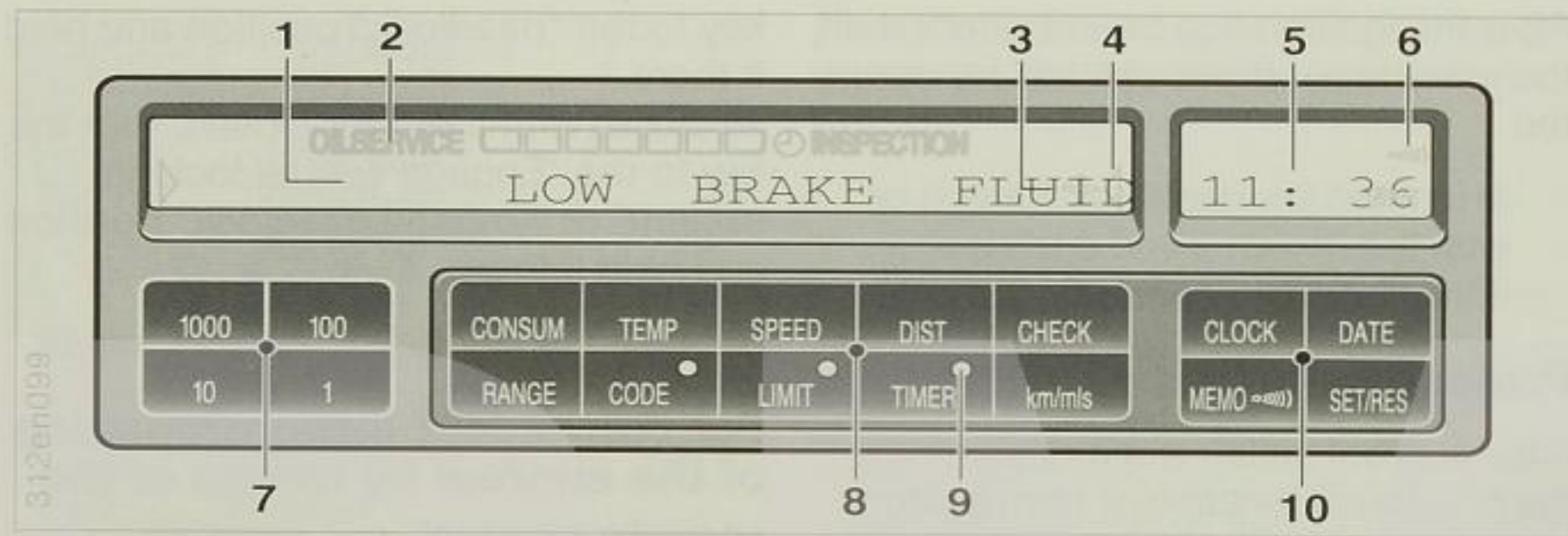

- | | |
|---|---|
| 1 Display | 6 Sound-wave symbol for reminder function |
| 2 Service Interval indicator | 7 Numerical input keys |
| 3 Plus signs indicate that further displays are present | 8 Information keys |
| 4 Fault display symbol | 9 Light-emitting diodes (LED) |
| 5 Digital clock | 10 Function keys |

The MID contains:

- ▷ Service Interval indicator 53
- ▷ Digital clock with date display 54
- ▷ On-board computer
For information and calculations with contribute towards safer and more economical driving 56
- ▷ to operate the independent heat/ventilation control 60
- ▷ to activate the immobilizing device 62
- ▷ Check Control 64

Explanations and operating instructions for the various functions and displays are given on the following pages.

Service Interval indicator

Valid for all systems:

Unrealistic numerical inputs are not accepted by the computer.

Each time a numerical input key (7) is pressed the value increases by one digit. If the key is held down, the value increases by one every half second.

A numerical input erases the previously memorized one.

Figures can be altered and input in any convenient order.

The value is input to the memory by pressing the SET/RES key.

To clear the display, press the CHECK button.

If the power supply is interrupted, for instance when a battery is charged, all the memorized data are erased. After restoring the power supply the time, date and any previously stored switch-in times, distance and speed limit values must be input again.

If the "PPPP" fault display appears, consult BMW Service.

Green light-emitting diodes (LEDs):

the fewer are on, the sooner the next service will be due.

Yellow LED in conjunction with OIL SERVICE or INSPECTION:

comes on when service work is due.

Red LED:

maintenance work is overdue.

Clock symbol with INSPECTION:

shows that a brake fluid change is due.

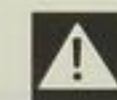

Periods during which the battery has been disconnected are ignored by the display. Take any such periods into account with regard to the specified brake fluid renewal intervals (two years) and do not wait until the brake fluid renewal reminder is displayed. ◀

All displays go out after the engine has been started.

The BMW Service station resets the service interval indicator to the original display after the maintenance work has been carried out.

For further details, please see page 140 and refer to the car's Service Booklet.

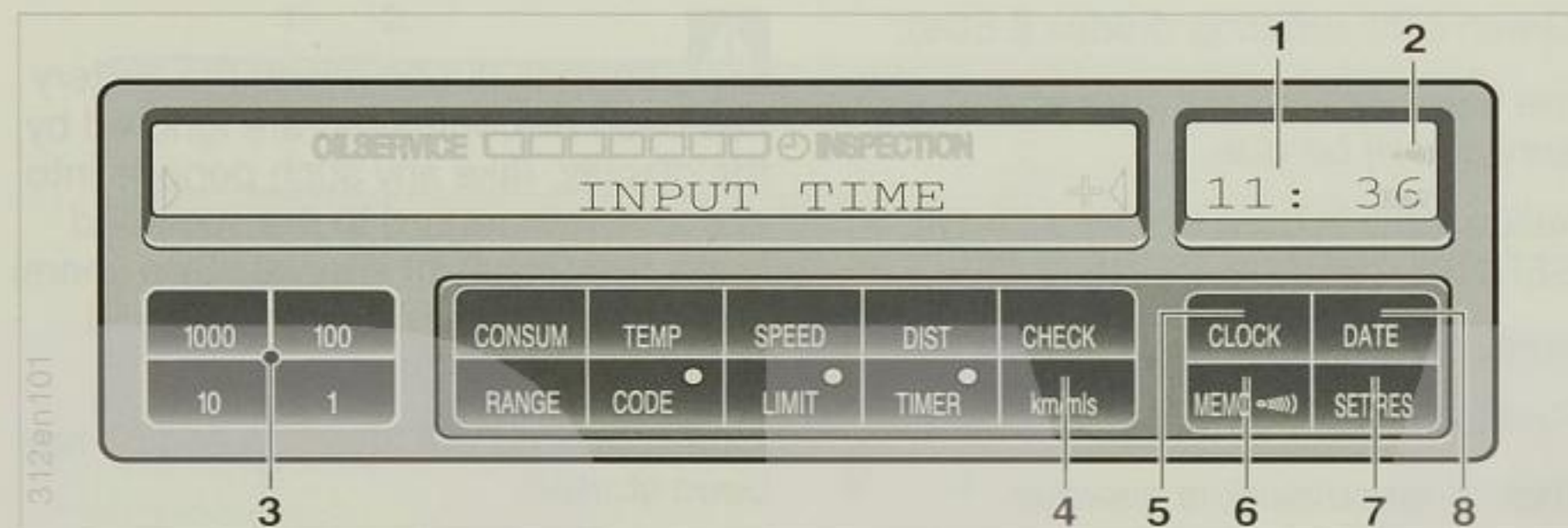

- 1 Digital clock display
- 2 Sound wave symbol for memo function
- 3 Numerical input keys
- 4 Display unit changeover key

- 5 Clock function key
- 6 Memo function key
- 7 Start/Stop key
- 8 Date function key

The digital clock can be used to

- ▷ call up the time and date
- ▷ program a reminder signal (Memo) every hour, for instance so that radio news bulletins are not missed.

Call up the time and date

Press the appropriate function key (5/8).

In ignition key position 0 or with the ignition key removed, the display appears only for a few seconds; in ignition key position 1 and beyond, the value remains on display

You can have the time displayed as a 12- or 24-hour clock and the date in European or American order. Change-over:

Press the function key (either TIME OR DATE) and the display units changeover key (km/mis) at the same time.

When the 12-hour clock is in use, the letters AM or PM appear at the right of the display.

Memo function

Press the MEMO key to switch this function on and off.

The signal is heard 15 seconds before every full hour. A sound-wave symbol appears in the clock display to indicate that the MEMO function has been selected.

Digital clock

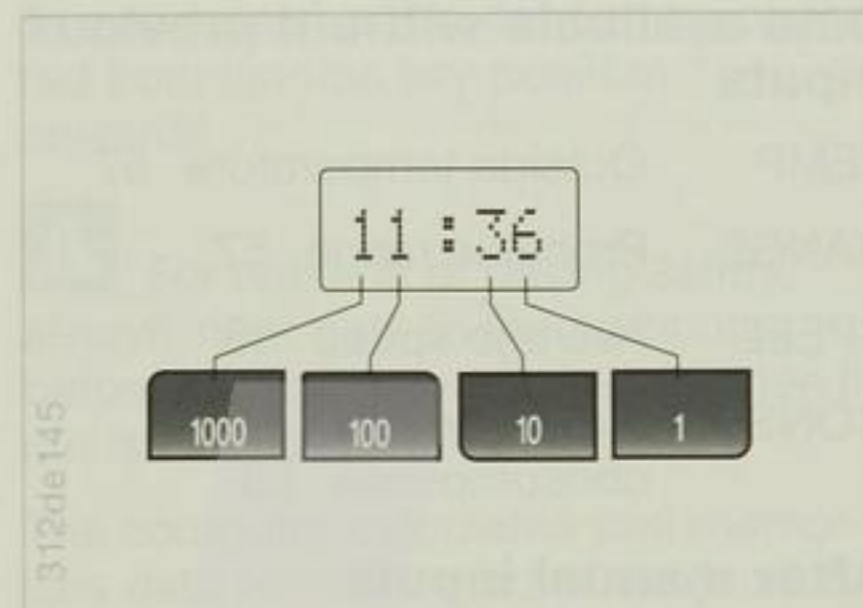

Inputs

All time and date settings are made by way of the numerical input keys according to the following principle:

The digits can be input in any order. Each time a key is pressed, or if it is held down for half a second, the value increases by one.

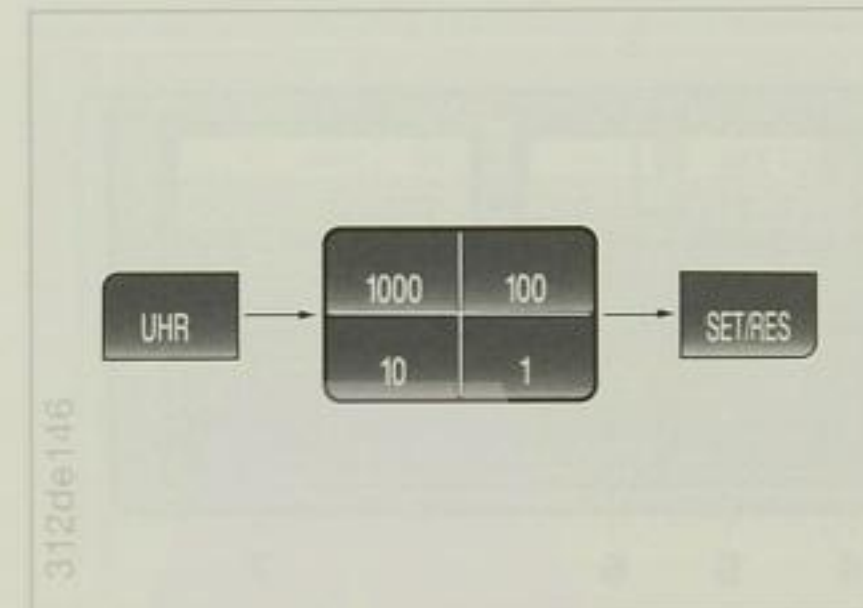

Altering the time display

(Press the TIME key until the MID displays "INPUT TIME" and the time display flashes.)

Altering the date display:

(Press the date key until the MID displays "INPUT DATE" and the date display flashes.)

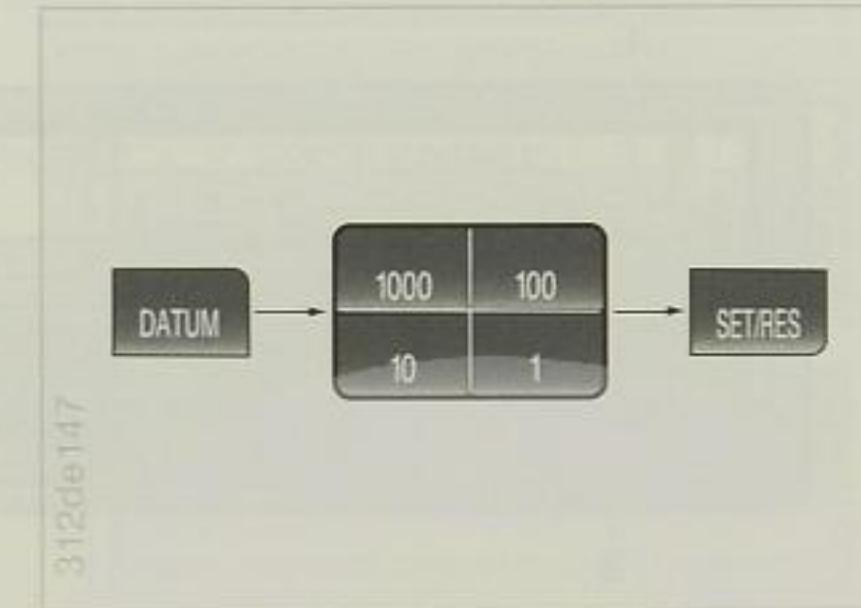

If necessary, input the year before pressing SET/RES if the display calls for this input (INPUT YEAR). (The device takes leap-years into account, so that no special manual adjustment is necessary.)

After a power supply interruption

The time display flashes and the MID displays "INPUT TIME."

- ▷ Input the time at the numerical input keys.
- ▷ Press SET/RES. The clock will start to run.

The MID displays "INPUT DATE."

- ▷ Input the correct date at the numerical input keys.
- ▷ Press SET/RES.

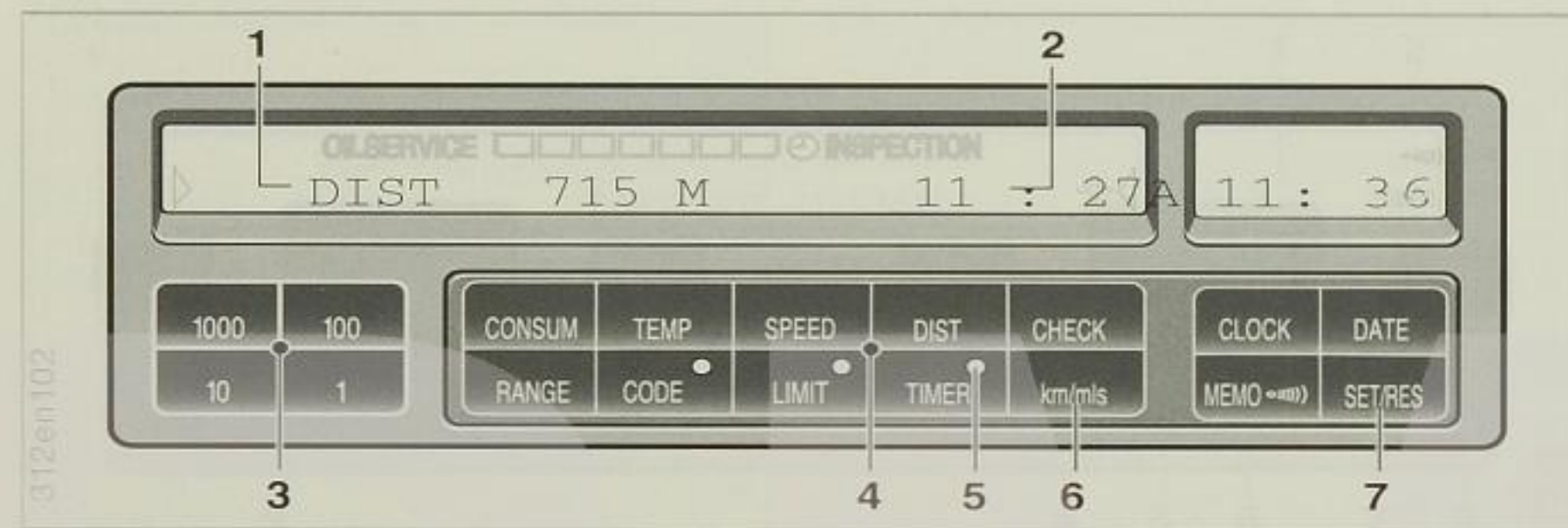

- 1 Display
- 2 Time of arrival
- 3 Numerical input keys
- 4 Information keys

- 5 Light-emitting diodes (LED)
- 6 Display unit changeover key
- 7 SET/RES key (start/stop)

The on-board computer can be used to call up and display information which contributes to safe, economical driving.

Data available without previous inputs

TEMP	Outside temperature	57
RANGE	Probable range	57
SPEED	Average speed	58
CONSUM	2 average fuel consumptions	58

After manual inputs

DIST	Distance before destination is reached, with time of arrival	58
LIMIT	Speed limit	59

Control functions

The following systems are controlled by the on-board computer:

TIMER	2 switch-on times for independent heater/ventilation control	60
	Direct operation of heater/ventilation control	61
	Stopwatch	60
CODE	Immobilizing device	62

The on-board computer can be operated from ignition key position 1 onwards.

! For reasons of driving safety, always input data to the computer before starting your journey or when the car is at a standstill. ◀

The computer calculates and memorizes data from the start of the journey onwards.

Information can also be displayed by operating a remote control; see page 63.

The changeover key (6) enables information to be displayed either in metric or Imperial units of measurement.

▶ Check Control warnings displace the computer displays. ◀

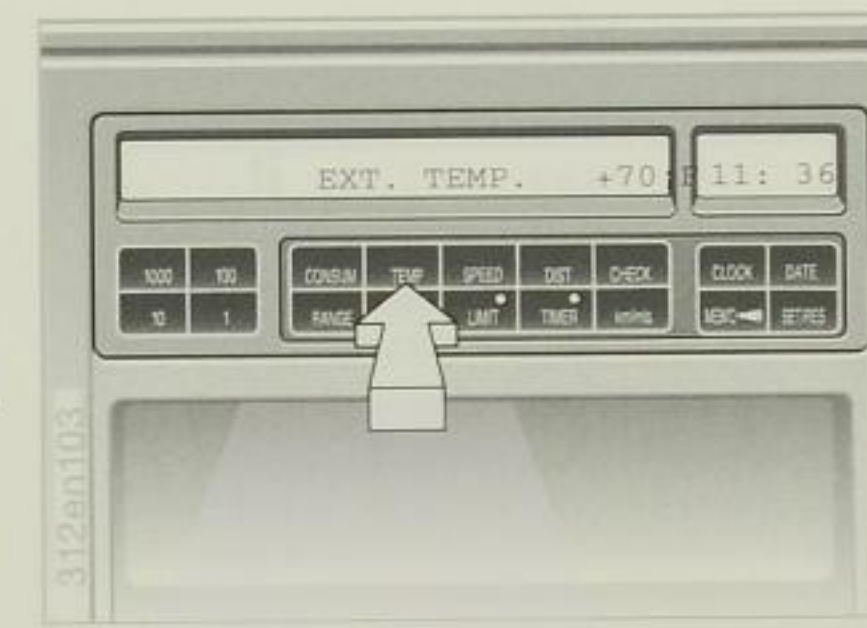

Outside temperature

To display: Press the TEMP button.

If the outside temperature falls below +3°C, a gong signal is heard as a warning; the outside temperature is displayed and flashes for 8 seconds.

The warning is repeated if the temperature rises to at least +6°C and then drops again to +3°C.

! Whether or not a temperature warning is given, remember that ice can still form on the road at above +3°C in certain circumstances, for instance on bridges and in shadows. ◀

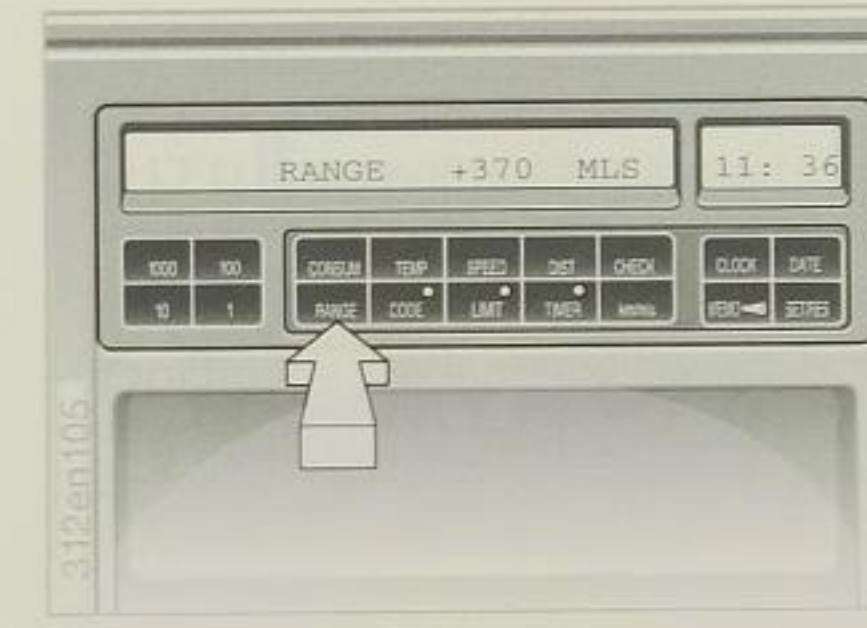

Probable range

This display indicates how far the car can probably be driven on the fuel remaining in the tank. The value takes into account the way in which the car has been driven so far.

To display: press the RANGE button. A plus sign (+) in front of the displayed value means that it is still undergoing a correction process (measuring tolerance).

If three display segments flash, the range is below 15km and the car should be refuelled as soon as possible.

The on-board computer registers fuel added to the tank only

- ▶ if the quantity exceeds 4 litres and
- ▶ when the engine has been stopped.

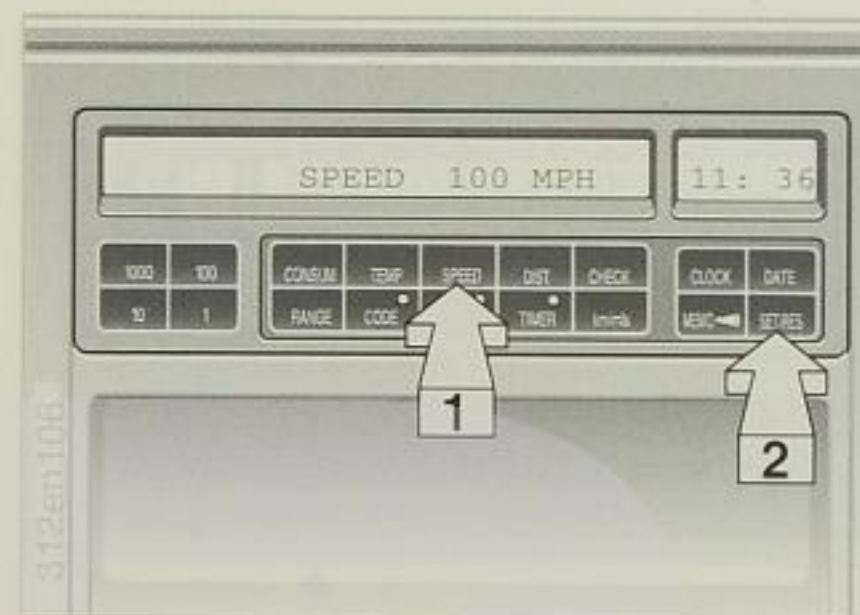

Average speed

To start computing:

Press the keys in the order illustrated.

To display: press the SPEED key.

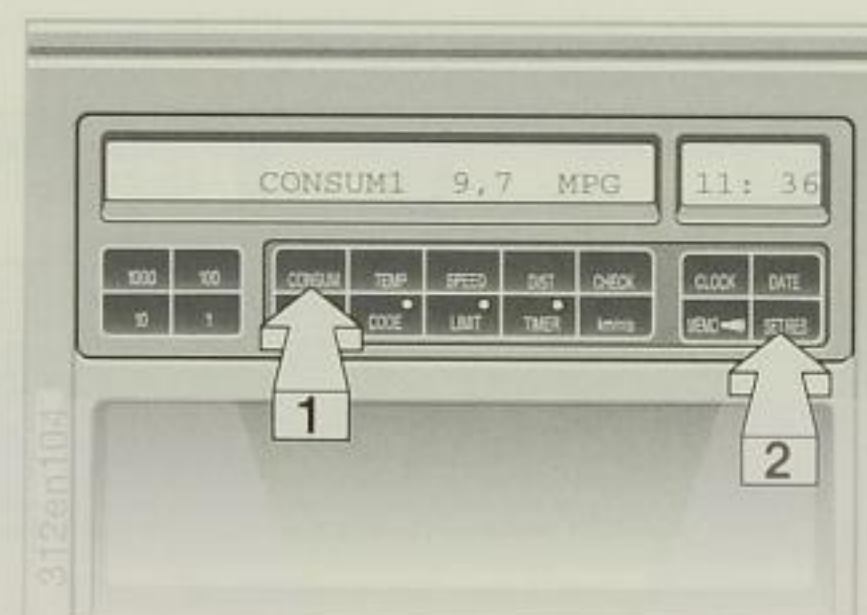

Average fuel consumption

Average fuel consumption can be computed for two distances in parallel, for instance a complete journey and one section of the journey.

To start computing for distance 1: press the keys in the order illustrated.

To start computing for distance 2: press the buttons again in the order illustrated.

To display: press the CONSUM button. Each time this button is pressed, the display alternates between the average consumptions for distances 1 and 2. There is also an indication of whether distance 1 or 2 is being displayed.

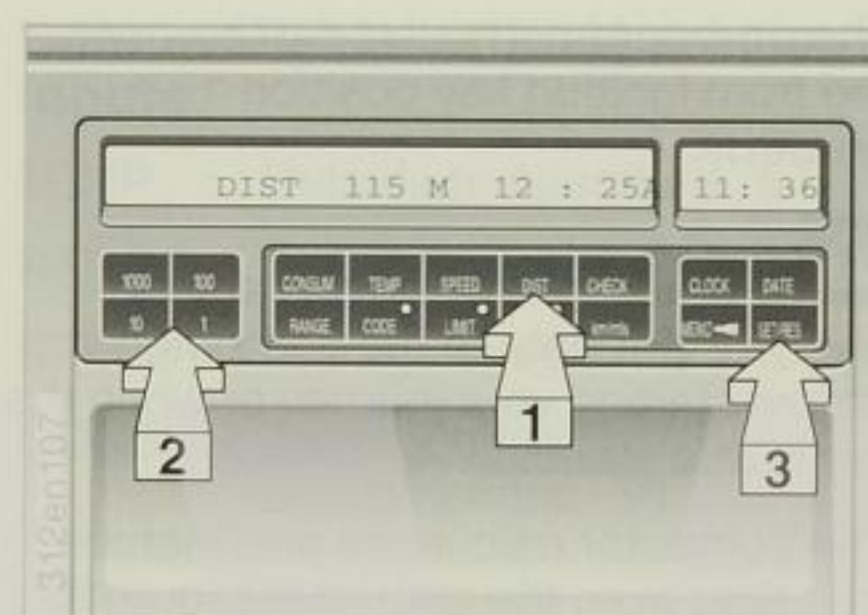

Distance from destination

Shows how far the car is from your destination, provided that the total distance was input before the journey started.

Distance input: press the keys in the order illustrated.

To display: press the DIST button.

The probable time of arrival, which is recalculated continually as driving conditions change, is also displayed.

If the car has already completed the full distance which was input at the start of the journey, the distance value is preceded by a minus sign.

On-board computer

Display units changeover:
Press km/mls changeover key once

▷ to alter the distance display

or twice

▷ to alter the arrival time display.

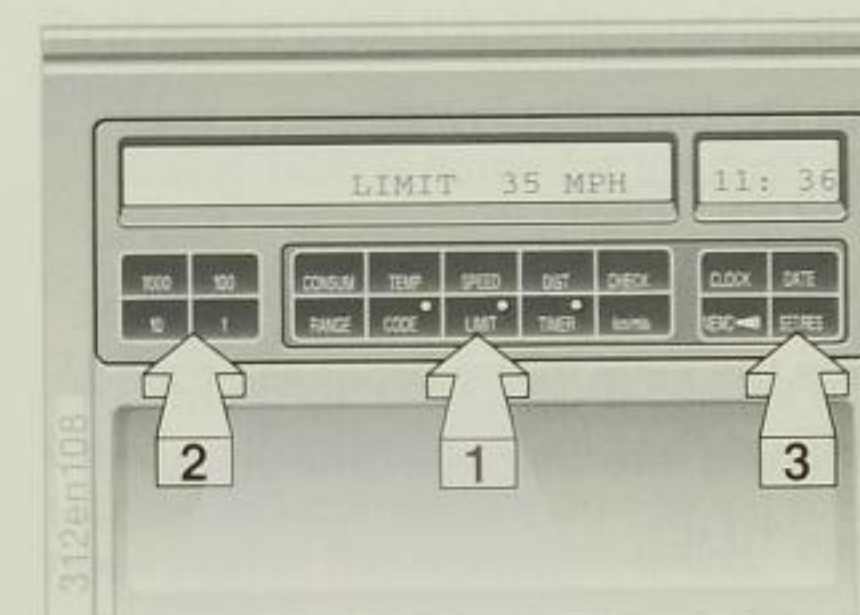

Speed limit

If you exceed a speed limit which you have previously input (for instance in order not to exceed the legal speed limit), a warning will be given. The corresponding LED flashes and the display briefly shows the stored limit.

The warning is only repeated if the speed of the car drops by at least 5km/h and the speed limit is subsequently exceeded again.

Speed limit input:

Press the keys in the order illustrated. The LED will come on.

Cancelling the speed limit input:
Press the LIMIT button again.

The LED goes out but the stored value is not lost and can be re-activated with the LIMIT button.

Adopting the car's actual speed as the limit value:
Press the LIMIT and SET/RES button.

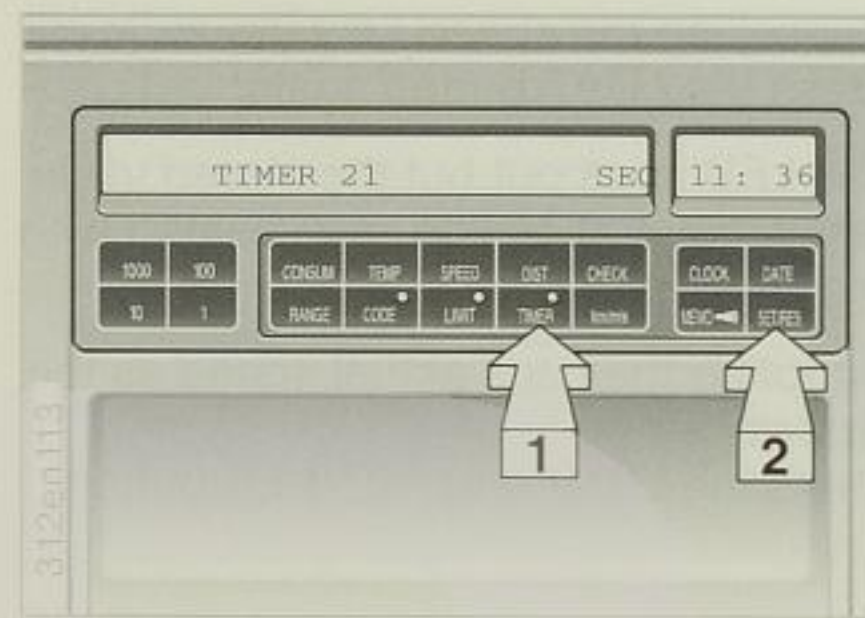

Stopwatch*

The stopwatch function is only available on cars without independent heater and ventilation control. It runs for 99 hours, 59 minutes. The time appears in the display: at first in seconds and tenths of a second, after one minute in minutes and seconds, and after one hour in hours and minutes.

Start:

Press the keys in the order illustrated. The LED comes on and the cumulative time is shown in the display.

Stop:

With the time displayed:
press SET/RES.

If any other information is displayed:
press the keys in the order illustrated.

Obtaining intermediate time value:
press TIMER.

The LED flashes and the intermediate time is displayed. The stopwatch continues to run.

Obtaining main stopwatch time display again:

press TIMER again.

▶ The stopwatch ceases to run in ignition key position 0, but runs again in ignition key position 1. ◀

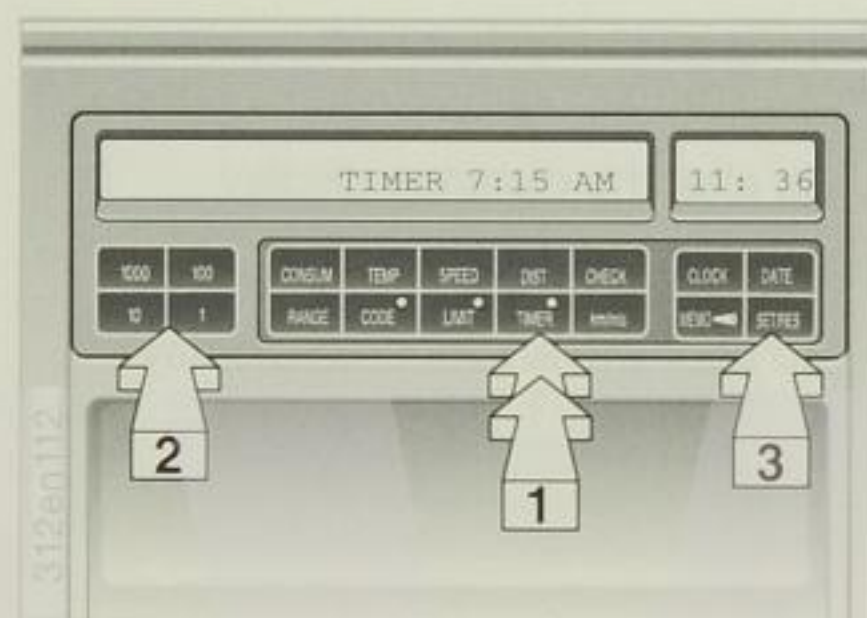

Independent heater/Programming independent ventilation

Input of switching times:

You can preselect two switch-on times for the heater or ventilation control. The function depends on outside temperatures: the heater can be operated below 16°C, the ventilation above 16°C. The heater or ventilation is switched off again automatically after 30 minutes.

For important information on operating the independent heater/ventilation control, see page 84.

When the TIMER button is pressed, the display shows the current operating condition of the independent heater/ventilation control.

Input of first switch-on time:
input is possible only if the digital clock is running and the ignition key is in position 1.
Press the keys in the order illustrated (press TIMER twice).

Input of second switch-on time:
press the keys again as illustrated, but press TIMER only once.

Correcting the time input:

Press the keys in the order illustrated, including the different time input. After the input the display shows * and the LED comes on as a sign that a switch-on time has been preselected. The LED flashes while the heating or ventilation is actually in operation, and goes out when they are switched off.

To check a previous switch-on time input:

- ▶ Press TIMER twice for the first time input.
- ▶ Press TIMER three times for the second time input.

The switch-on time inputs can be activated as follows (heating and ventilation starts-LED comes on) and stops (LED goes out) at the specified times:

press SET/RES after selecting the desired switch-on time.

The switch-on times remain stored until cancelled by a new input.

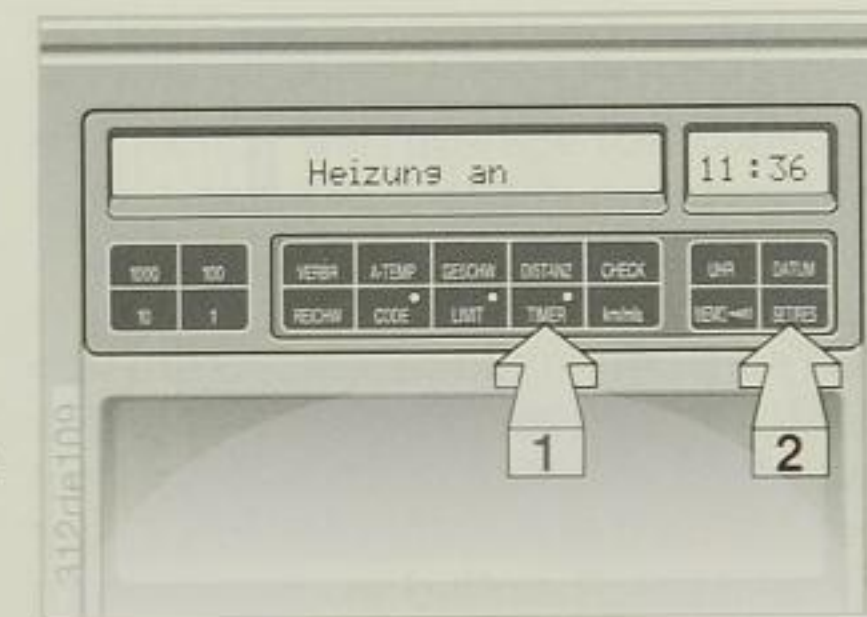

Direct switch-on of independent heating/ventilation control

This is only possible in ignition key position 1. Press the keys in the order illustrated.

Direct switch-off of independent heating/ventilation control

In ignition key position 1- press the keys in the order illustrated.

In ignition key position 0 or 1, press SET/RES only.

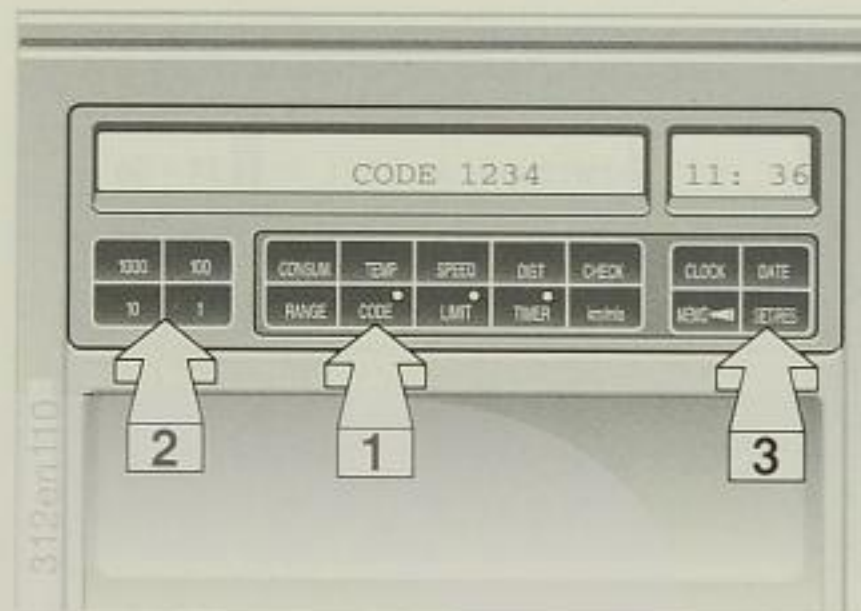

Immobilizer

The engine compartment lid, radio and any attempts to start the engine are monitored.

The device is activated with a code number. Starting the engine, removing the radio or opening the engine compartment are then impossible unless the code number is input correctly. For this reason: always remember the code number you have chosen!

Activating in ignition key position 1:

Press keys in the order illustrated, then turn ignition key to position 0 and remove.

Any code number from 0000 to 9999 can be input. (The code number must be input each time the device is activated.)

In ignition key position 0 or with the key removed, the LED will remain on for up to 36 hours. If the LED flashes for about 10 seconds, the engine compartment is not properly closed or the radio removed.

De-activating in ignition key positions 1 or 2:

the gong signal and the "----CODE" display call for the driver to input the chosen code number.

- 1 Input the code number at the numerical input keys.
- 2 Press the SET/RES key.

If attempts are made to start the engine without a code input or if the incorrect code is entered, the gong will sound and the engine will not start.

If the code number has been forgotten, proceed as follows:

- 1 Disconnect the battery, then reconnect it. The alarm will sound.
- 2 Turn the ignition key to position 1. A time display will appear and run down for 15 minutes.
- 3 After 15 minutes, the engine can be started.

If the code number becomes available again during this 15-minute waiting period: press the keys in the order illustrated.

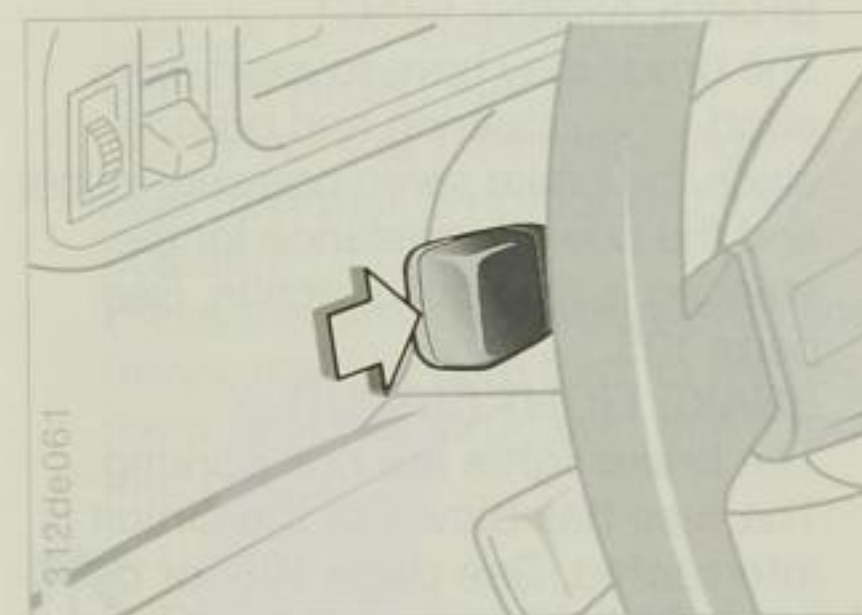

Remote control

The flashing turn indicator lever can also be used to display on-board computer information.

You must first program the items of information you wish to have displayed.

Input:

- 1 Press in the turn indicator lever until the display shows "PROG 1."
- 2 Press the computer information buttons for the displays you need. The program number appears in the display for each input.
- 3 Press the SET/RES button.

If you wish all the information to be accessible:

- 1 Press the turn indicator lever until "PROG 1" appears.
- 2 Press SET/RES.



The following should be noted in connection with average fuel consumptions 1 and 2 and switch-on times 1 and 2 for the independent heater/ventilation control: to show both consumption figures, the CONSUM button must be pressed twice. To obtain only CONSUM 2, for example, but not CONSUM 1, press the CONSUM button and then the km/mls changeover button. (Each time the changeover button is pressed, the display will alternate between average fuel consumptions 1 and 2.) Adopt the same procedure for independent heater/ventilation control switch-on times 1 and 2 if required. ◀

To display:

Press the turn indicator lever in briefly as often as necessary.

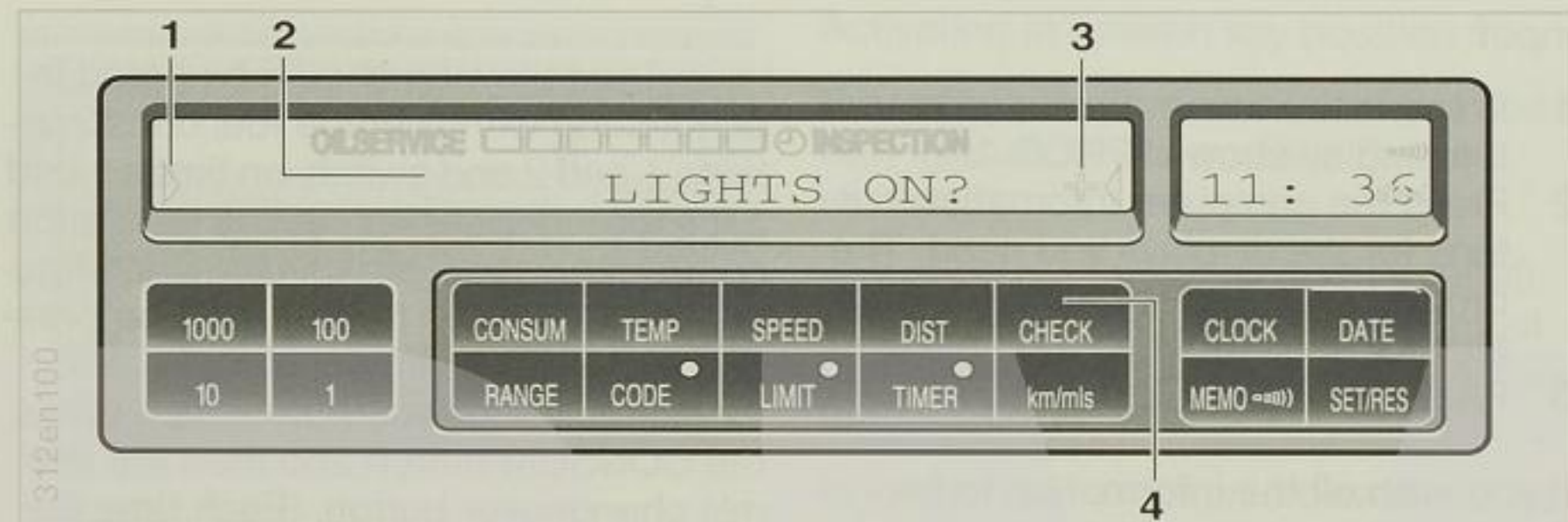

System malfunctions are shown in plain text, and a gong warning is sounded. There is also a general warning light on the instrument panel which comes on during the journey if a fault signal is present.

- 1 Fault display symbol
- 2 Display
- 3 Plus sign for further fault displays
- 4 CHECK button

A system of 3 priority categories has been adopted for the fault signals:

Priority 1

These faults are shown immediately with a gong signal and flashing indication in the display (1). If several faults develop simultaneously, they are displayed in succession. These displays remain active until the fault is rectified and cannot be cleared with the CHECK button (4).

▷ HANDBRAKE ON

This signal appears shortly after the car has begun to move.

- ▷ BRAKE ASSIST INACT.
The driver may have to exert extra effort when steering and braking, since the brake servo pressure is lost and the power assistance for the steering is also out of action. See page 105.
- ▷ BRAKE LIGHT CIRCUIT
The brake lights are not working. The fuse has blown or the circuit is interrupted. See page 108, or consult a BMW Service station.
- ▷ BRAKE LIGHTS FAILURE
The brake lights themselves have failed – bulbs blown. Renew defective bulbs. See page 121.
- ▷ LOW BRAKE FLUID
Brake fluid level is close to the minimum mark. Top up at the earliest opportunity. See page 101. Have the cause of the brake fluid loss rectified by a BMW Service station.
- ▷ ENGINE OIL PRESS LOW
Engine oil pressure has dropped too low. Stop the car immediately and switch off the engine. See page 16.
- ▷ COOLANT TEMPERATURE
The temperature is too high. Stop the car immediately and switch off the engine. See pages 19, 102.

Check Control

- ▷ CHECK LEFT BACKREST
CHECK RIGHT BACKREST
The driver's or front passenger's seat backrest is not locked into position. Press the seat back rearwards and down, making sure that its movement is not obstructed, until it locks into position.



The seat belt cannot provide full protection unless the seat back is correctly locked into position. ◀

- ▷ CATALYST OVERHEAT
Stop the car and allow it to cool down until the display goes out. If necessary, consult a BMW Service station.
- ▷ SPEED LIMIT
Displayed if the car is driven faster than the maximum national speed limit. Comply with all applicable regulations.

Priority 2

These malfunctions are displayed in ignition key position 2 (but priority 1 signals are automatically superimposed). After the text displays have gone out, symbols remain visible to indicate that there are further fault messages in the memory. If the plus sign (3) appears, further signals are present – and can be displayed by pressing the CHECK button.

- ▷ CHECK BACKREST LOCK
The seat back lock sensor is defective. Consult a BMW Service station.
- ▷ CHECK P.A.S. FLUID
Level in fluid reservoir too low. See page 100.
- ▷ R/AXLE FAILSAFE PROG
The Active Rear Axle Kinematics (AHK) have cut out as a result of a fault. The car can still be driven. If the steering wheel is slightly off-centre when driving in a straight line, the car will veer slightly from the chosen line of travel. See page 131.
- ▷ BOOTLID OPEN
Appears only when the car is driven away for the first time.
- ▷ 1 BRAKE LIGHT FAIL
One brake light bulb has blown. See page 121.
- ▷ LOW BEAM FAILURE
SIDE LIGHT FAILURE
TAIL LIGHT FAILURE
F/FOG LIGHT FAILURE
R/FOG LIGHT FAILURE
NUM PLATE LIGHT FAIL
In each case the bulb or the fuse has blown, or the circuit is defective. See pages 108, 119, or take the car to a BMW Service station.
- ▷ TRANS.FAILSAFE PROG
Defective electronic control unit on automatic transmission cars. See page 71.
- ▷ BRAKE LININGS
The brake pads are worn. See page 105.
- ▷ WASHER FLUID LOW
Top up at the next opportunity. See page 103.

Priority 3

Displayed primarily at the end of the journey in ignition key position 0 (if several signals are present, they are displayed in succession, but priority 1 and 2 signals take precedence over priority 3).

Even with the ignition key removed and the display blank, you can recall fault signals with the CHECK button for up to 2 minutes, provided that the cars doors remain closed.

You can also call up fault signals in ignition key position 2 before a journey is started. The displays go out after a short time or when the car is driven away, and no indicator symbols remain visible.

The signals are repeated only in ignition key position 0.

If a plus sign is visible: call up further fault signals by pressing the CHECK button.

- ▷ **CHECK ENGINE OIL LEV**
Engine oil level has dropped to near the permissible minimum. Add oil at the next opportunity (for instance when refuelling). See page 98.

- ▷ **LIGHTS ON**
Displayed at the end of the journey (when the driver's door is opened).
- ▷ **KEY IN IGNITION LOCK**
A gong signal is also heard.
- ▷ **FASTEN SEAT BELTS****
The warning light with seat belt symbol also comes on.

To test the Check Control display (only when no signals are shown):

In ignition key position 2, press the CHECK button: the display should show "CHECK CONTROL O.K."

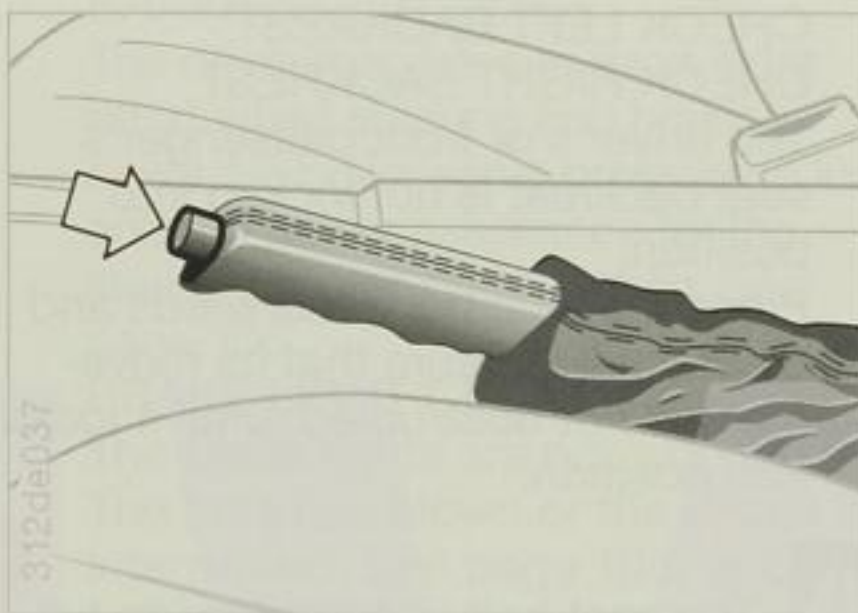
Handbrake**Applying**

The lever has a ratchet which holds it on automatically. The "P" telltale light on the instrument panel comes on.

Releasing

Pull up the lever slightly, press the knob on the end and lower the lever.

The handbrake acts on the rear wheels. If it has to be applied while the car is moving, do not pull the lever up too hard, or else the rear wheels could be over-braked and the tail of the car could slide.

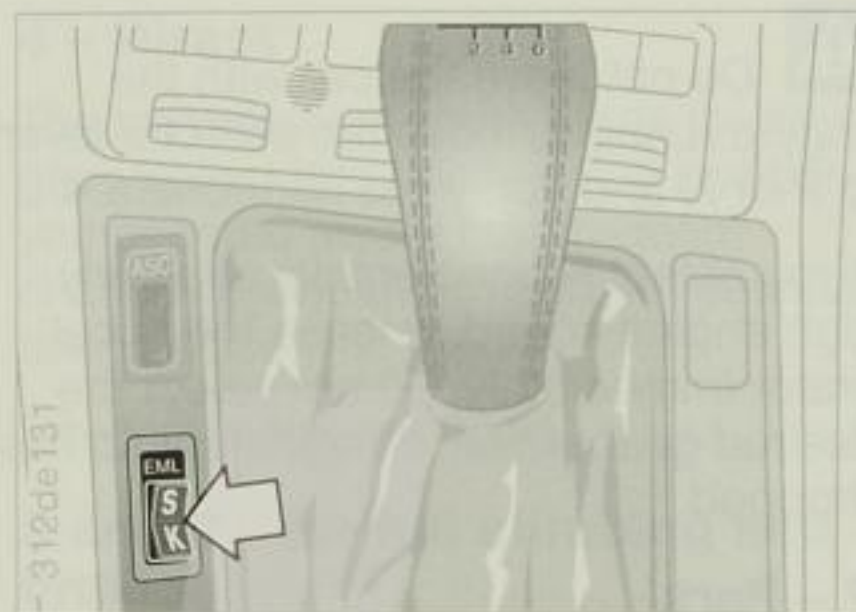

The brake lights do not come on when the handbrake is applied. ◀

EML

Electronic engine output control (EML) has two programs for operation of the accelerator pedal: "comfort" and "sport".

Switch positions

K – Comfort setting, for driving at a moderate engine power or on a wet or slippery road

S – Sport setting

The switch is illuminated in ignition key position 2. Only the S setting is shown on the instrument panel.

If the EML warning light on the instrument panel indicates a malfunction, take the car to a BMW Service station.

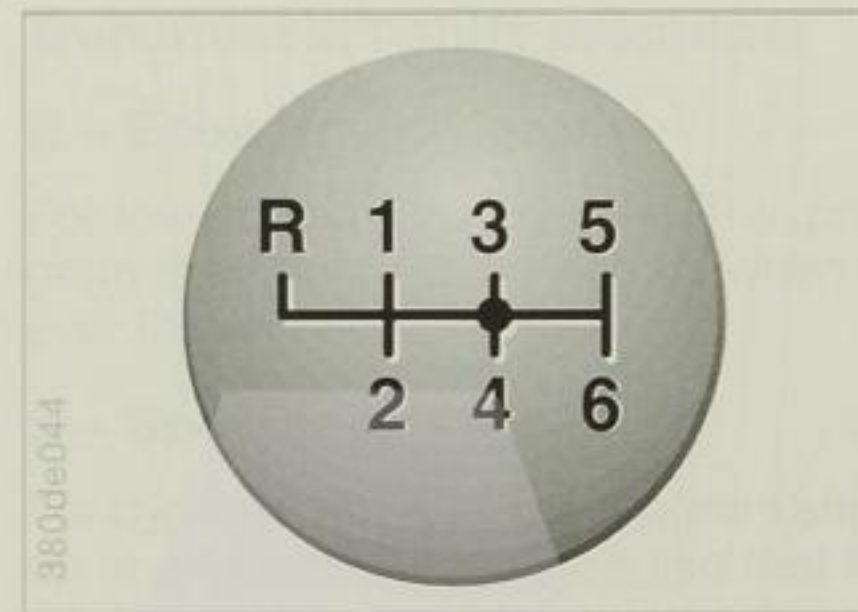
Manual gearbox

The normal rest position for the gear lever (marked by a dot) is in the 3rd/4th gear plane of the gate.

When neutral is selected from any gear, the lever moves back to this position.

All gears are synchromeshed.

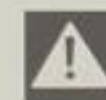

When selecting 5th or 6th gear, the lever must be pressed firmly to the right to ensure that 3rd or 4th gear is not selected accidentally. ◀

Reverse

Engage this gear only when the car is standing still. Press the gear lever to the left until slight resistance is overcome.

Reversing lights

These come on in ignition key position 2 when reverse gear is selected.



Never hold the car on an uphill gradient by slipping the clutch. Always apply the handbrake. A clutch that is allowed to slip will wear rapidly. ◀

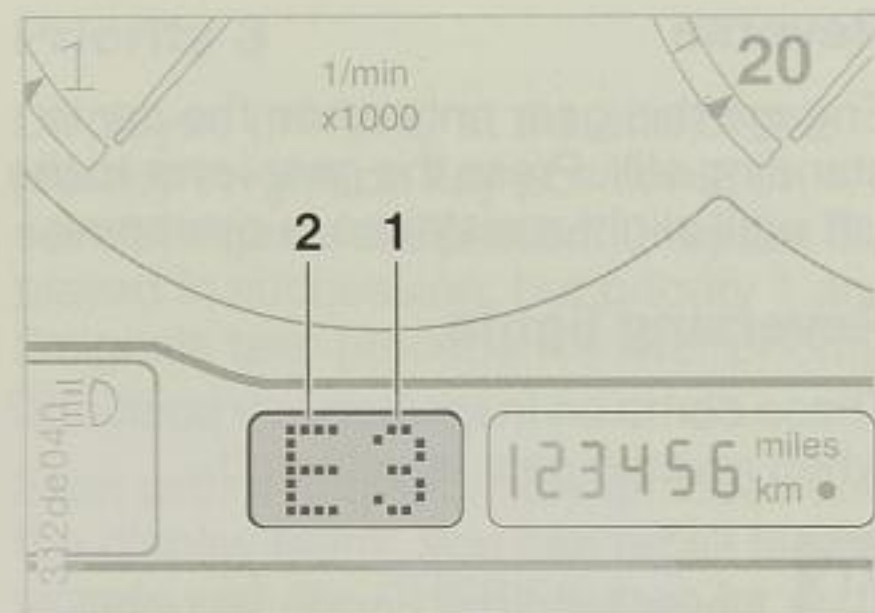

Automatic transmission (BMW 840Ci)

Selector lever positions (1) P R N D 4 3 2

There are also three driving programs (2), which are selected at a separate program switch:

E	(Economy)	Press the switch
S	(Sport)	Slide the switch
*	(Winter)	in the desired direction

For details of the programs, see page 69.

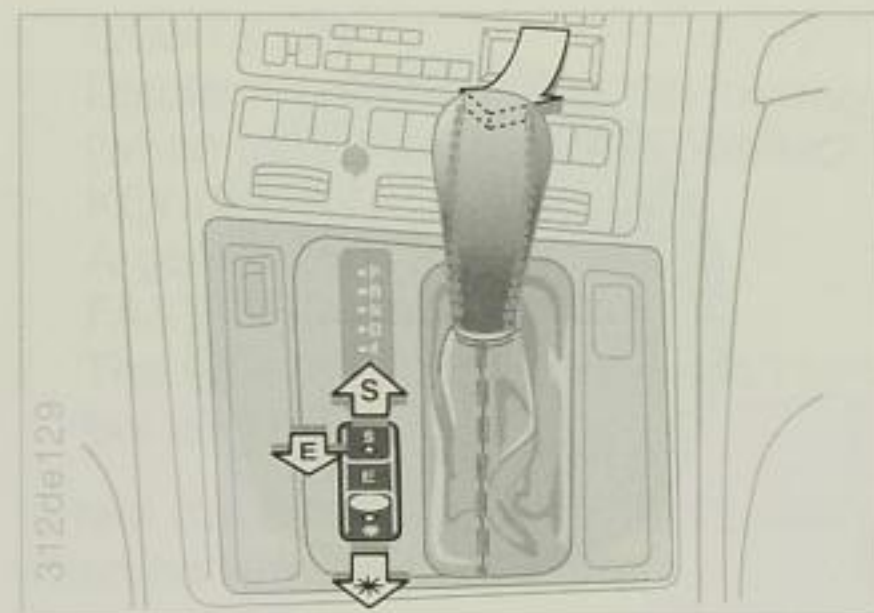

There is a locking catch on the front of the selector lever handle, which prevents it from being moved accidentally to various positions. Press this catch to release.

 The engine can only be started in the P or N position. If the engine is running, even if you do not touch the accelerator, the car will move if a gear is selected. After selecting a gear, wait for it to engage before depressing the accelerator. ◀

 Do not leave the car with the engine running: move the selector lever to P or N and apply the handbrake. ◀

If you select N accidentally at a fairly high engine speed, release the accelerator immediately. Do not select the desired gear until the engine speed has dropped.

P – Park

Engage only when the car is standing still. The drive wheels are locked.

R – Reverse

Engage this gear only when the car is standing still.

N – Neutral

Select only if the journey is interrupted for a fairly long time. When the car is being driven at speed, only select neutral if a skid occurs.

D – Drive (all gears of automatic transmission available)

Use this position for all normal driving. All forward gears are selected by the transmission as necessary.

4 – Direct

The transmission shifts up as far as 4th gear. Select this position if in position D you become aware that frequent changes between 5th and 4th gears are taking place.

5th gear is not engaged.

3 and 2 – for hill climbing and braking

Select these positions to restrict the choice of gears on mountain roads and lengthy uphill or downhill gradients.

In position 2, 1st gear is selected automatically. The transmission settings which take effect in this position make it particularly suitable for towing a trailer.

The transmission shifts down at points which correspond approximately to the limits of the engine speed ranges in each gear.

"Kick-down"

To obtain maximum acceleration, the accelerator pedal can be depressed beyond the normal full-throttle position, at which a pressure point must be overcome.

Transmission shift programs

E – Economy program

For low-consumption driving. This program is automatically selected whenever the engine is started.

S – Sport program

For dynamic driving. This program shifts up at a higher engine speed so that full advantage is taken of the engine's power reserves.

* – Winter program

For wintry driving conditions. In position D, gears 2 to 5 are selected to allow more efficient progress in wintry conditions.

The gear selected is maintained in positions 4, 3 and 2. This means that the car also starts off in this gear and does not shift down when accelerating hard.

It is a good idea, e.g. on inclines or when towing a trailer, to drive in selector lever position 2, or in position 4 in winter, since this makes it possible to start off smoothly on slippery roads and avoids unwanted gear shifts.

"TRANS FAIL-SAFE PROG" signal on MID display:

An electronic control unit or an automatic transmission malfunction is indicated. All selector lever positions are available, but in the forward travel positions the car remains in 4th or 5th gear.

In this situation, avoid severe loads and take the car to the nearest BMW Service station without delay.

 Never work inside the engine compartment if a gear has been selected at the automatic transmission. Never leave children unattended in the car. ◀

For tow-starting, towing away and starting with a flat battery, see pages 110, 111, 112.

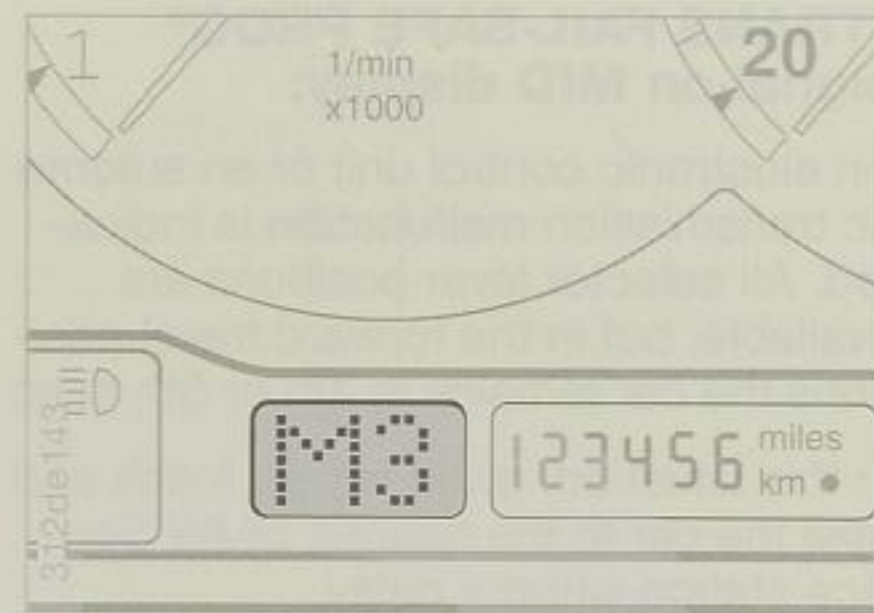

Automatic transmission with STEPTRONIC and Adaptive Transmission Control (AGS) BMW 850Ci

Selector lever positions: P R N D M

Adaptive program	D
Manual mode	M
- shifting up	+
- shifting down	-

The display (see illustration) shows selector lever positions P R N and D or, in manual operation, M1 to M5.

See page 71 for notes on the manual mode and page 72 for details of the adaptive program.

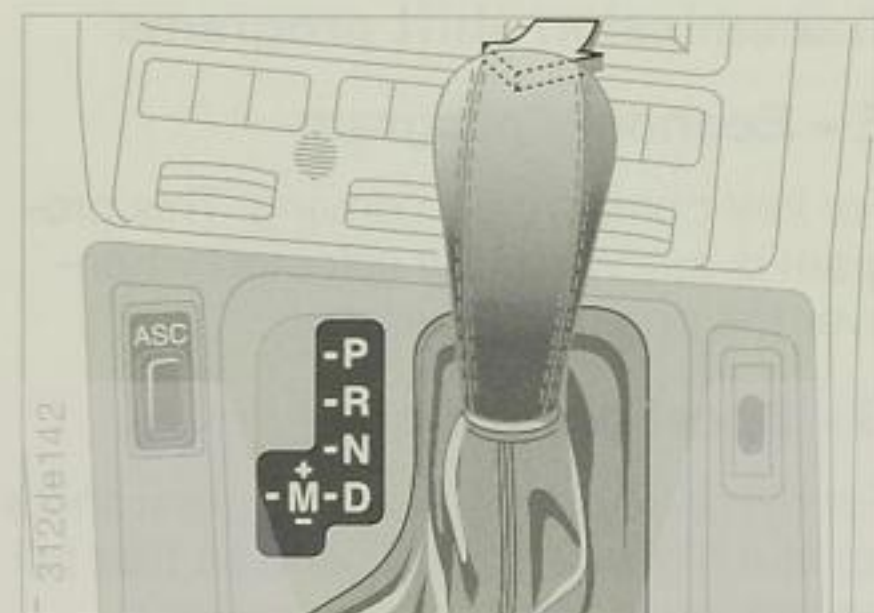

There is a locking catch on the front of the selector lever handle which prevents the lever from being moved accidentally to positions R and P. Press this catch to release.

 The engine can only be started in the P or N position. ◀

If the engine is running, even if you do not touch the accelerator, the car will move if a gear is selected.

After moving the lever, wait for the selected gear to engage before depressing the accelerator.

 Do not leave the car with the engine running: move the selector lever to P or N and apply the handbrake. If you select N accidentally at a fairly high engine speed, release the accelerator immediately. Do not select the desired gear until the engine speed has dropped. ◀

P - Park

Engage this gear only when the car is standing still. The drive wheels are locked.

R - Reverse

Engage this gear only when the car is standing still.

N - Neutral

Select only if the journey is interrupted for a fairly long time. When the car is being driven, only select neutral if a skid occurs.

D - Drive (all gears of automatic transmission available)

Use this position for all normal driving. All forward gears are selected by the transmission as necessary.

"Kick-down"

To obtain maximum acceleration, the accelerator pedal can be depressed beyond the normal full-throttle position, at which a pressure point must be overcome.

M - Manual mode

Manual-shift plane M at the lever can only be reached from automatic-shift position D.

When changing to the manual-shift mode, the gear currently selected in the automatic program remains in use.

To select a gear manually, move the lever a short distance in the correct direction:

- ▷ To shift up, push forwards in direction +.
- ▷ To shift down, push backwards in direction -.

If an up- or down-shift is not permissible in the circumstances (for instance, a down-shift at too high an engine speed), it is ignored. The selected gear is displayed briefly on the instrument panel. If several shifts are made in quick succession, the last rejected gear is displayed briefly. After this, the gear in actual use is displayed.

 When driving in the manual mode, to accelerate from a low speed when in 4th and 5th gear, e.g. for overtaking, it is necessary to shift down manually or operate the kick-down. ◀

The transmission can only shift from M to selector lever positions P, R and N via D.

Special functions

In the manual operating mode, the following special functions may influence the selection of individual gears:

- ▷ To prevent the engine from overspeeding, the next-highest gear is automatically selected in all gears shortly before the governed limit is reached.
- ▷ At low speeds, the system automatically shifts back as far as 3rd gear without driver intervention. Downshifts take place at the following speeds:
 - 5th - 4th gear, at approx. 50km/h (30 mile/h)
 - 4th - 3rd gear, at approx. 30km/h (20 mile/h).
- ▷ The kick-down selects the lowest gear which can be engaged without engine overspeeding.
- ▷ The car can be driven away from a

standstill in 2nd or 3rd gear in certain situations, for instance in winter.

"TRANS FAIL-SAFE PROG" signal on MID display

An electronic control unit or an automatic transmission malfunction is indicated. All selector lever positions are available, but in the forward travel positions the car remains in 4th or 5th gear.

In this situation, avoid severe loads and take the car to the nearest BMW Service station without delay.

 Never work inside the engine compartment if a gear has been selected at the automatic transmission. Never leave children unattended in the car. ◀

For tow-starting, towing away and starting with a flat battery, see pages 110, 111, 112.

Adaptive program (AGS)

In selector lever position D, the Adaptive Transmission Control system automatically chooses the most suitable shift program from those at its disposal. It continuously adapts to the manner in which the car is being driven (e.g. calm and relaxed or harder and more dynamically), to road influences (smooth surfaces, severe uphill gradients etc.) and to actual driving circumstances (e.g. twisty roads, descending steep gradients).

Special functions

In selector lever position D, the Adaptive Transmission Control system influences the shift points by means of various special functions.

This has the effect of suppressing certain shifts that would normally have occurred, and may cause others to take place in certain circumstances although the driver would not have expected them.

Selection of winter program

When driving on slippery surfaces (snow and ice), a winter shift program is selected automatically. The car moves away from a standstill in 2nd gear and shifts up to higher gears as early as practicable. This makes progress over slippery surfaces easier and enhances the car's traction and dynamic stability.

AGS switches out of the winter program as soon as a higher-grip road surface is identified or the ASC+T is switched off.

Cruise control

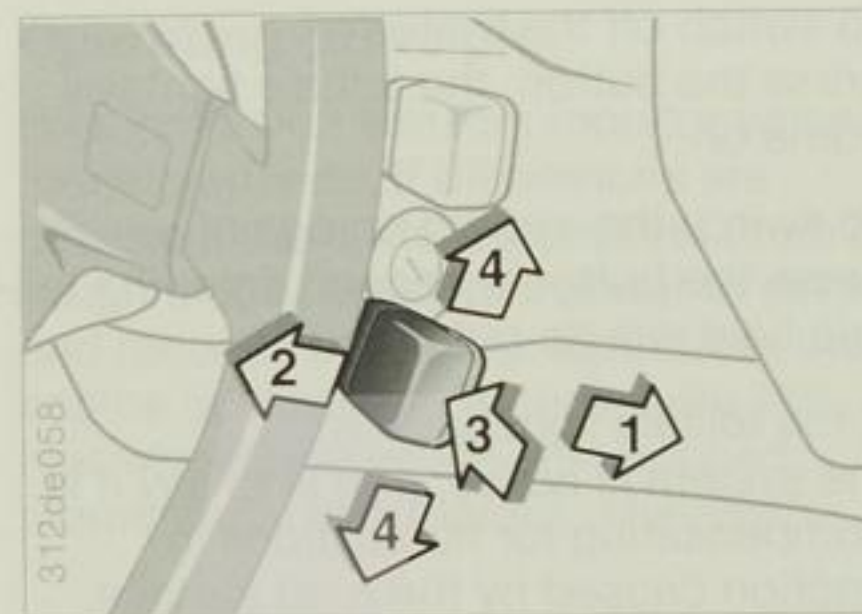

Any desired road speed above approx. 40km/h can be memorized and maintained automatically.

The memorized speed value is lost when the engine is switched off.

1 Acceleration

Moving the lever briefly:
The actual speed of the car is maintained and memorized. Each time the lever is moved briefly to this position again, road speed is increased by approx. 1 km/h.

Holding the lever in this position:
The car accelerates without the accelerator pedal being touched. When the switch is released, the speed then reached is maintained and memorized.

2 Deceleration

Holding the lever in this position:
The car decelerates by automatic restriction of the throttle, provided it was previously travelling at a controlled speed. When the switch is released, the speed then reached is maintained and memorized.

Moving the lever briefly:
Each time the lever is moved briefly, the road speed is reduced by approx. 1 km/h if it was previously travelling at a set speed.

3 Resume

Moving the lever briefly:
The speed last memorized is recalled and maintained once it has been reached again.

4 Off

Moving the lever briefly:
The cruise control facility is switched off immediately.

The cruise control is also switched off automatically:

- ▷ If the car exceeds the selected speed by approx. 16km/h
- ▷ If the car's road speed falls more than 8km/h below the selected speed
- ▷ If a high rate of deceleration occurs (above 1.5m/s²), for example on a steep hill, when braking and declutching or if the automatic transmission selector lever is moved from D to N.

! Do not use the cruise control on twisting roads, if traffic is heavy or in any other situation which makes it too difficult to maintain a constant speed, nor when the road could be slippery (snow, rain or ice) or on a loose surface (stone chippings or sand). ◀

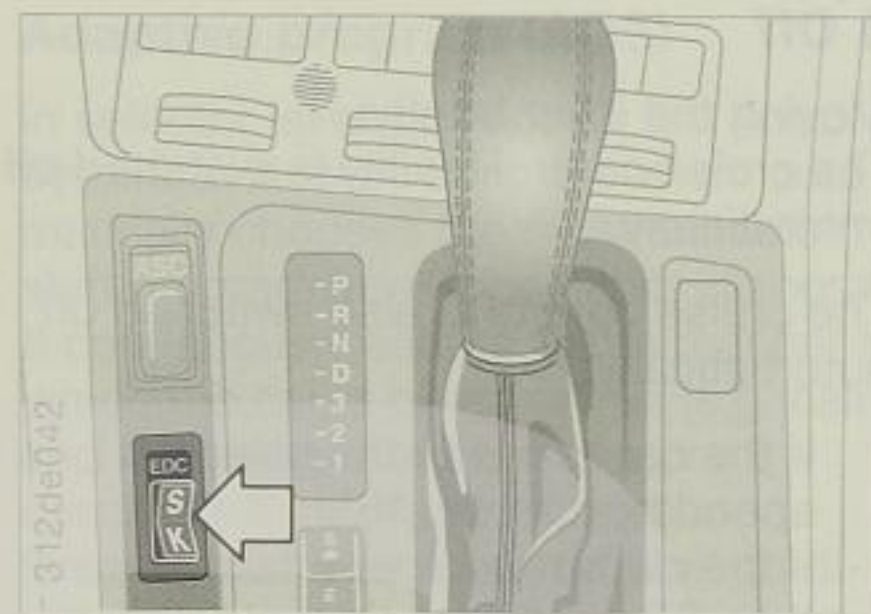

The electronic damping control (EDC) automatically ensures that the desired degree of suspension damping is provided, and thus enhances both safety and ride comfort.

The Comfort program is selected each time the engine is started.

Switch positions:

K – Comfort Program

S – Sport program

The driver can switch from one program to the other at any time.

In ignition key position 2, the selected switch position is illuminated.



Automatic Stability Control plus Traction (ASC+T)

This system improves driving stability, particularly when accelerating and cornering.

The system is ready to operate whenever the engine is started.

The telltale light in the instrument cluster goes out after the engine has been started.

To switch off the system: press the button; the telltale light will come on.

To switch the system on again: press the button a second time; the telltale light will go out.

If the telltale light flashes: the system is active, that is to say it is compensating for fluctuations in traction caused by the road surface.

If the telltale light does not go out after the engine has been started or comes on during the journey:

the system is defective, but the car itself is fully operational with the exception of the ASC+T stability control function.

Take the car to a BMW Service station to have the fault repaired.

Operating principle

High-precision sensors monitor wheel rotating speeds. If differences are detected, the system interprets them as a sign that wheelspin is about to set in, and reduces the power input from the engine accordingly. If necessary, the rear wheel brakes are also applied momentarily to suppress wheelspin.

Although the action of this system may seem to be restricting available engine power and therefore be difficult for the driver to accept, it should be remembered that as much traction as can be achieved, and therefore optimum acceleration, are always available for the prevailing road, driving and climatic conditions without exceeding the limits of dynamic stability.



Even with ASC+T, the basic laws of physics continue to apply. If the maximum possible speed in any given situation is exceeded, traction and cornering force may be lacking. The driver alone is responsible for avoiding this situation. The additional safety potential offered by this stability and traction control system must never be understood as an invitation to take additional risks. ◀

The system reacts sensitively if tyres of different makes and types are used on the same car. You should therefore try to ensure that all the car's tyres are identical in make, type and tread pattern.

By switching off ASC+T it is possible to revert to the conventional driveline (without electronic control). It may be desirable, for instance, to switch off the system to ensure maximum potential traction

- ▷ If the car has to be rocked out of a hollow on a soft surface, or started in deep snow or on a loose surface.
- ▷ If snow chains are fitted.

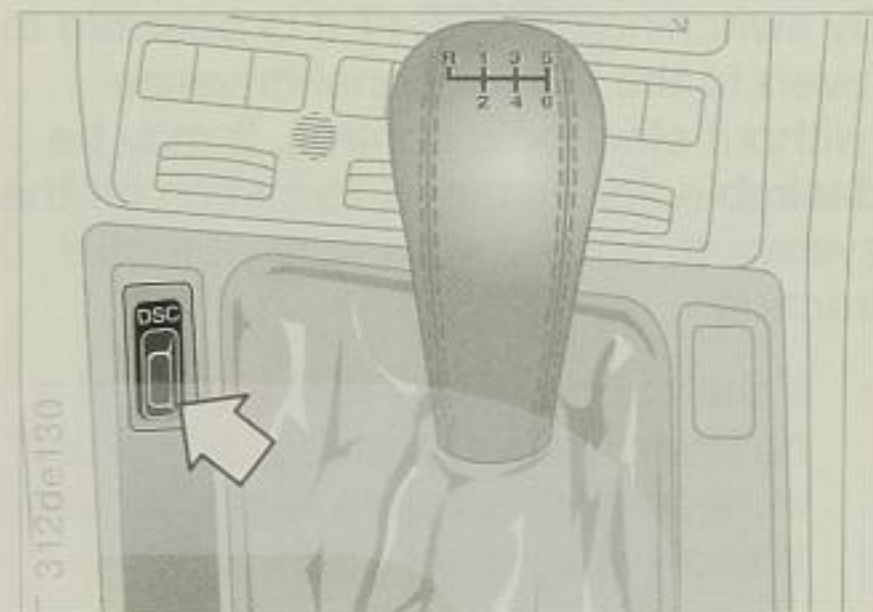

DSC is a further extension of Automatic Stability Control + Traction (ASC+T).

It improves dynamic stability, particularly where lateral forces are encountered (e. g. cornering) and when accelerating.

It identifies and counteracts unstable driving situations and prevents the drive wheels from spinning in poor-grip or otherwise unfavourable conditions (slippery surfaces, bends).

The system comes into action automatically whenever the engine is started.

The telltale light on the instrument panel goes out when the engine has been started.

To switch off the system:

Press the key; the telltale light will come on.

To re-activate the system:

Press the button again; the telltale light will go out.

Telltale light

If the telltale light flashes: the system is active, that is to say it is compensating for fluctuations in traction caused by the road surface.

If the telltale light does not go out after the engine has been started or comes on during the journey:

the system is defective, but the car can still be driven normally with DSC out of action. Take the car to a BMW Service station for repair.

Operating principle

Highly-sensitive sensors monitor wheel rotating speeds and the steering lock angle. If wheel speeds vary or differ from the calculated value at a given steering lock angle, the system registers the likelihood of wheelspin and reduces engine output accordingly; if necessary, either drive wheel can be braked momentarily to prevent it from spinning.

Although the action of this system may seem to be restricting available engine power and therefore be difficult for the driver to accept, it should be remembered that as much traction as can be achieved, and therefore optimum acceleration, are always available for the prevailing road, driving and climatic conditions without exceeding the limits of dynamic stability.

When the system is functioning and the brakes are being applied, a certain amount of noise is generated.



Even with DSC, the basic laws of physics continue to apply. If the maximum possible speed in any given situation is exceeded, traction and cornering force may be lacking. The driver alone is responsible for avoiding this situation. The additional safety potential offered by this system must never be understood as an invitation to take additional risks. ◀

The system reacts sensitively if tyres of different makes and types are used on the same car. You should therefore try to ensure that all the car's tyres are identical in make, type and tread pattern.

By switching off DSC it is possible to revert to the conventional driveline (without electronic control). It may be desirable, for instance, to switch off the system to ensure maximum potential traction

- 1 if the car has to be rocked out of a hollow on a soft surface, or started in deep snow or on a loose surface,
- 2 if snow chains are fitted.

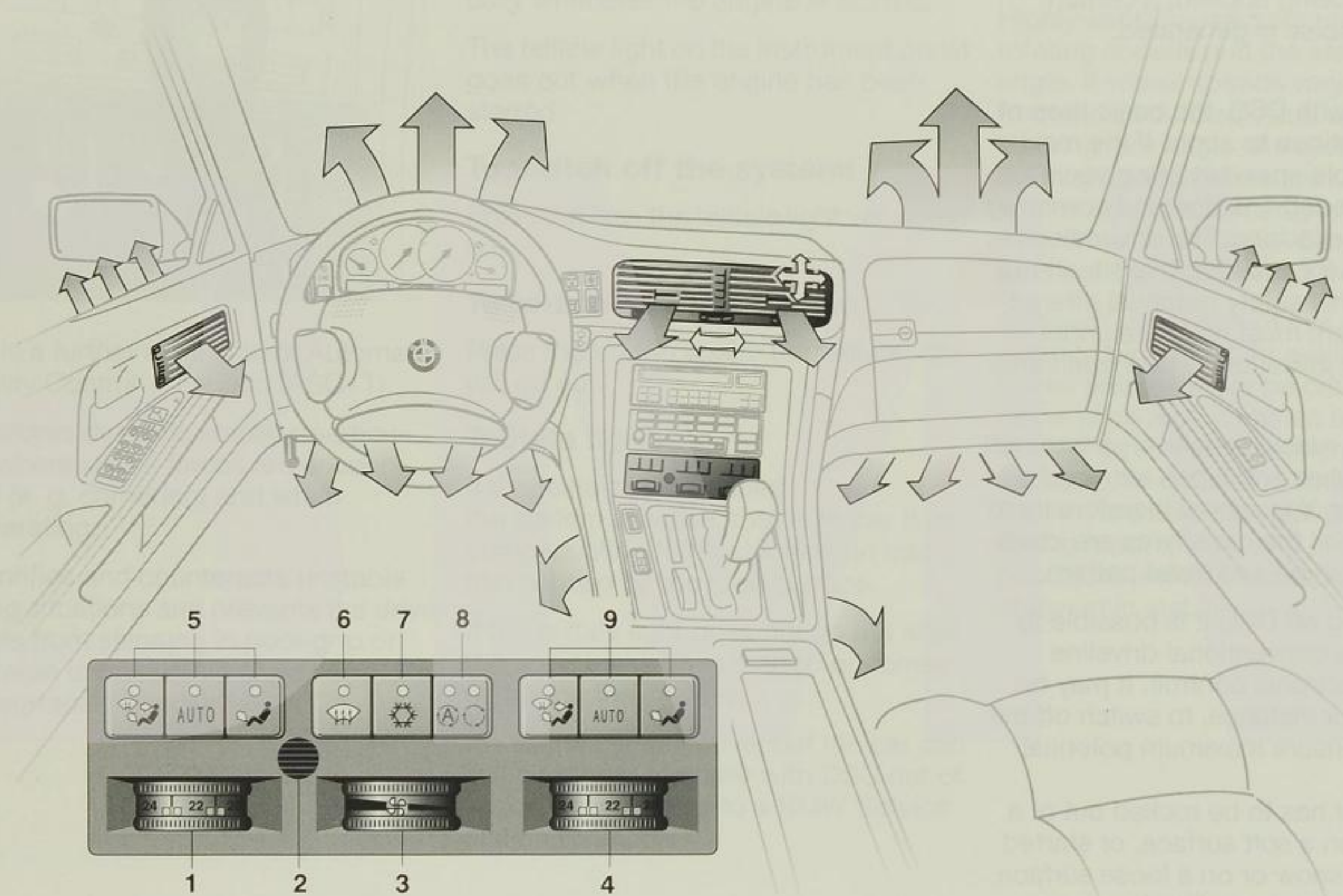

- 1 Temperature selector for left side of car
- 2 Air entry grille for interior temperature sensor – must not be obstructed
- 3 On/off switch and airflow volume selector
- 4 Temperature selector for right side of car
- 5 Program buttons for air distribution on left side of car
- 6 Pushbutton for maximum wind screen and side window demisting
- 7 Pushbutton for air conditioning system
- 8 Pushbutton for Automatic Recirculated Air Control (AUC) or for recirculated air operation
- 9 Program buttons for air distribution on right side of car

When a button is pressed, the corresponding LED lights up if the system was switched on at airflow volume selector wheel (3).

Temperature selectors for left and right sides of car

 The temperature control is switched on and off at the rotary knob on the driver's side:

Left-hand limit position: no heating effect, maximum cooling output, temperature control off.

As the control is turned to the right, away from the pressure point position: temperature control cuts in.

Right-hand limit position (pressure point): maximum heating output, temperature control off (also emergency position if a fault develops in the electronic temperature system).

The scales are merely intended as a guide for the interior temperature. The selected setting is reached as quickly as possible and does not normally need to be adjusted subsequently.

Alter settings by only small amounts at a time to avoid undesirable temperature fluctuations.

On/off switch and selector for airflow volume



Position 0: system is switched off, air intake closed.

Turned to the right as far as first pressure point: system switched on, minimum airflow.

Turned farther to the right: airflow increases.

Right-hand limit position (pressure point): maximum airflow volume (also emergency position if a fault develops in the electronic blower control system)

Program buttons for air distribution to left and right sides of car

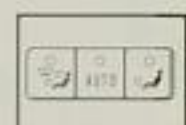

Automatic air distribution

 With only a few exceptions, this program can be used in all normal driving conditions for comfortable air-conditioning of the car interior.

Depending on actual temperatures, the air inlets are opened and closed automatically.

To ensure freedom from fatigue, the system works according to the "warm feet - cool heat" principle.

However, the air emerging from the instrument panel grilles can be varied separately in temperature; see next page.

To ensure that this program can operate effectively, some of the outlet grilles on the instrument panel and the doors must be open and the airflow volume selector should be turned past the first pressure point.

Air distribution through all grilles and outlets - no automatic control



This program is recommended in warm weather, for instance, if extra ventilation or cooling of the footwell areas is needed.



If the windscreen mists over on the outside when atmospheric humidity is very high, press the AUTO button or the airflow button for the footwell outlets only. No cooled air will then be directed onto the windscreen. ◀



Press this button to increase the airflow out of the ventilation grilles if the windscreen and side windows mist over during a journey and it would be undesirable to press button 6 (maximum windscreen and side window demisting). ◀

Airflow to the footwell outlets only



The demisting outlets are also slightly opened.

This program is recommended in cool weather, for example, when airflow from the grilles is not wanted, or to heat up the footwells rapidly.



In all programs, air emerges from the demisting outlets only at first after a cold engine has been started until the heater matrix has reached approx. 30°C. ◀

Pushbutton for maximum demisting and drying of the windscreen and side windows



The windscreen and the side windows can be cleared and dried rapidly with this program. The previously selected program is not lost.

For maximum effect, the engine must be at its regular operating temperature.

Pressing this button again (the LED goes out) automatically restores the previous settings of the system.

The windows mist or fog over as a result of moisture and condensate caused severe differences in temperature or a high level of humidity. The only remedy is to dry the glass with warm air.



The first time this button is pressed after engine starting, the rear window heating is also switched on. ◀

Air conditioning button



When this button is pressed, the air conditioning compressor is switched on above approx. +1°C outside temperature in all programs. The air is either cooled and dried or only dried as necessary.

If air humidity is very high, it is best to switch the air conditioning on in good time (before moisture condensate can reach the evaporator) and dry the air so that the windows do not fog over. Take care not to direct cooled air on to the windscreen, as it could otherwise mist or freeze over on the outside.

At the maximum cooling setting, the system switches over automatically to recirculated-air operation and the defroster outlets are closed.

We recommend leaving the air conditioning system switched on permanently in the summer.

Important notes on air conditioning system

It is common for the windows to mist over temporarily after the engine has been started and with the air conditioning system on.

Do not run the air conditioning system in lengthy cool spells, otherwise the windows will tend to mist over. In particular, frequent switching on and off can cause condensation to form on the windows.

When the air conditioning system is running, moisture and condensate produced by the evaporator is discharged under the car and may leave visible trails on the ground.

If the air conditioning system develops any faults, for instance if no cool air is delivered even when the controls are set accordingly, switch it off and consult a BMW Service station without delay.

Pushbutton for recirculated air mode



This is recommended if the outside air is dusty or smells objectionable. The air already inside the car then circulates through the system.

Although the air conditioning is switched on automatically at the same time to improve the quality of the air (and dry it), you should not drive too long with the system in the recirculated-air mode.



If the windows fog over when the recirculated-air mode is in use, switch to fresh-air operation and run the air conditioning by pressing button 7. ◀

Pushbutton for Automatic Recirculated Air Control (AUC)



Three functions are obtained in succession by pressing this button repeatedly, and confirmed by LEDs.

Fresh-air operation: LEDs off.

Normal operation with fresh air from outside the car.

AUC operation: left LED is on.

The system identifies peak pollutant loads in the outside air and prevents them from reaching the interior of the car.

A sensor measures the level of pollutants in the outside air. If the values increase, the system switches over automatically to recirculated-air operation.

Recirculated-air operation: the right LED comes on.



If the windows fog over when the AUC or the recirculated-air mode are in use, switch to fresh-air operation (LEDs go out) and run the air conditioning by pressing button 7. Noises heard after the engine has been switched off are caused by the actuating motors returning the ventilation flaps to their rest positions. ◀

Automatic air conditioning

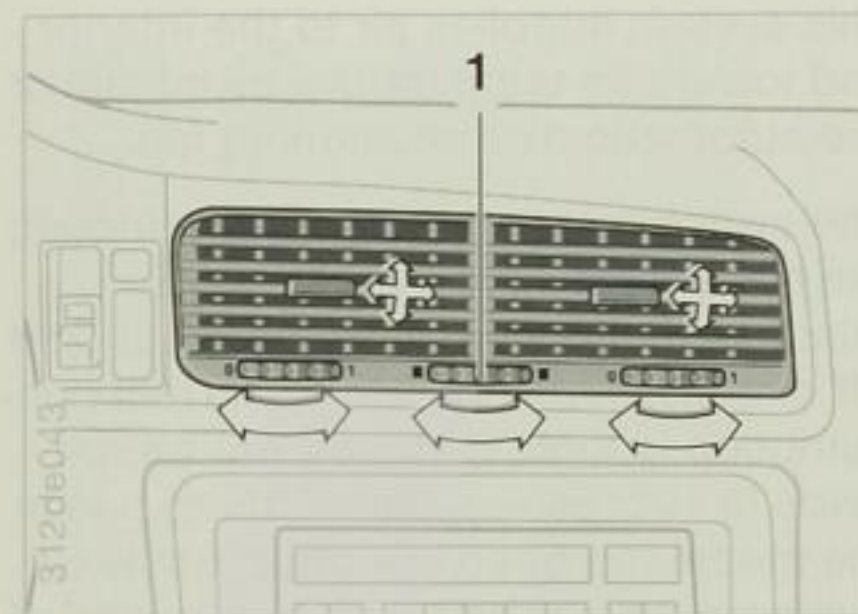

Warm feet and a cool head: Stratified interior air temperature for fatigue-free driving

The air emerging from the instrument panel and door grilles can be varied in temperature (except when maximum cooling is required):

Knurled wheel 1 turn to right – warmer
turn to left – cooler.

Micro-filter

Fresh air is drawn in through a micro-filter. This filters out up to 100% of all pollen and up to 60 % of dust particles in the air.

Change the filter at the car's regular servicing intervals. If airflow is noticeably lower than usual, this may indicate that the filter should be renewed earlier.

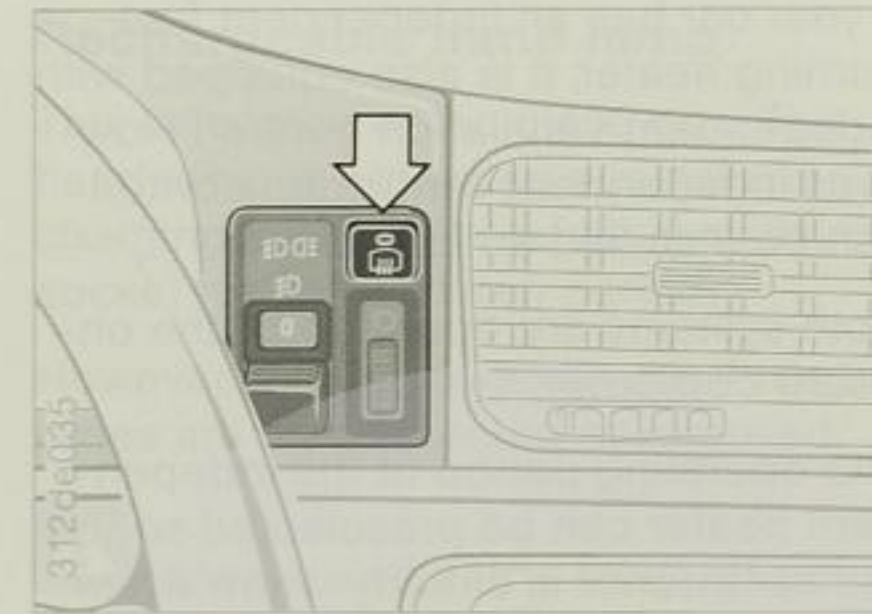

Press the button: while the telltale light is on the heated rear window is operating at full power (for rapid demisting).

When the telltale light goes out, the heated rear window has switched over automatically to a low rating in order to save power. It cuts out completely after about 20 minutes unless switched off previously.

If necessary, press the button again: This will start a new rapid demisting cycle.

To switch off: Press the button if the telltale light is on.

Whenever the engine is restarted, the heated rear window has to be switched on again if still required.

If your car has an independent fuel-burning heater, it is also equipped with independent ventilation control. However, independent ventilation control can be installed on its own.

Both systems are operated by the on-board computer; see page 60.

The operating period of the independent heater can be preselected so that the car interior is already warm when the journey is due to start. Snow and ice are also easier to remove from the windows.

The heater runs for 30 minutes at a time. Since its rate of current consumption is high, it should not be run twice in succession unless there has in the meantime been an opportunity to recharge the car batteries by a period of driving reasonable speeds.

The independent heater can also be switched on and off directly.

The independent heater can be run at outside temperatures below 16°C, but not while the car is being driven.

The heated air is supplied automatically to the defrosting and footwell outlets of the car; the heater runs at maximum output in all cases.

In ignition key position 1 you can vary the interior temperature (at the temperature selectors) and the air distribution (by means of the pushbuttons).

After it has been switched off (LED off), the independent heater continues to run for a short period.

If the independent heater does not start after a maximum of two attempts, or switches itself off automatically, consult a BMW Service station.

▶ Even during the warm season of the year, the independent heater should be run briefly about once a month. To do this if the temperature is above 16°C:

- ▶ Press the TEMP and TIMER buttons on the on-board computer at the same time: the "INV"(inverted) inscription will appear.
- ▶ Switch the independent heater on directly and switch off again after about 5 minutes. ◀

⚠ Never operate the independent heater in an enclosed space. Always switch off the independent heater before refuelling the car. ◀

Independent ventilation

This system supplies air to the interior and lowers its temperature by means of the automatic air conditioning fan.

The switch-on time can be preselected; the system runs for a period of 30 minutes. It can also be switched on and off directly. Since its rate of current consumption is high, it should not be run twice in succession unless there has in the meantime been the opportunity to recharge the car batteries by a period of driving at reasonable speeds.

Independent ventilation control is available at outside temperatures above 16°C, but not when the car is being driven.

Air is driven to the grilles in the instrument panel and doors. These grilles must therefore be opened before the independent ventilation control is switched on or preselected.

Roller sun blind

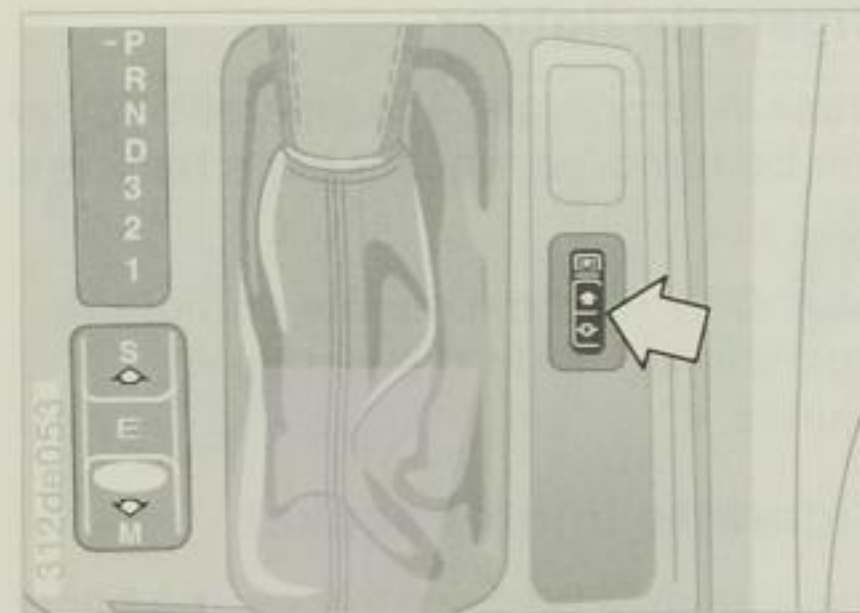

Electrically operated roller sun blind for rear window

To operate, touch the rocker switch; the ignition key must be in position 2.

Glove box

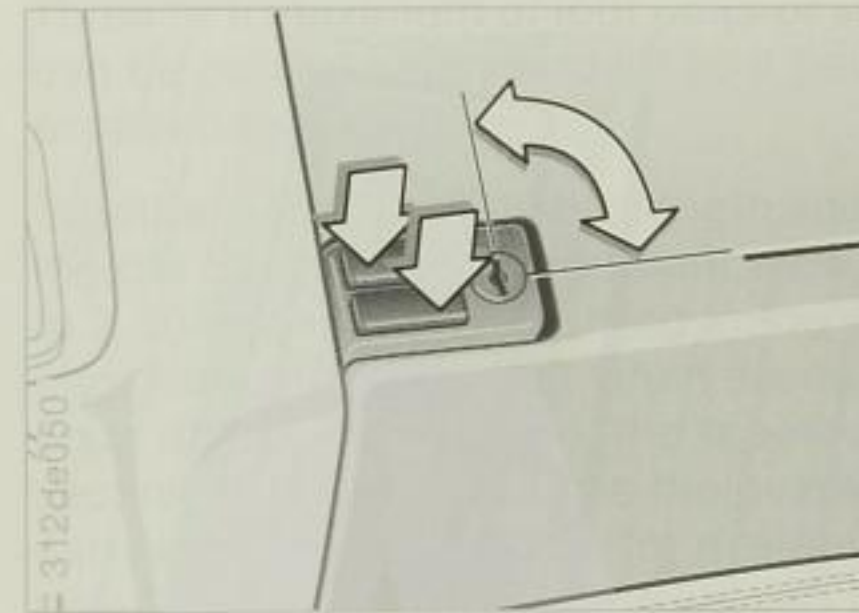

To open: press the appropriate catch.

The light inside will come on automatically.

To close: shut the lid.

To lock: this is only possible with a master key. When the glove box is locked, the luggage compartment is also locked.

⚠ To avoid risk of injury, the glove box should be kept closed when not in use. ◀

Rechargeable hand lamp

This is located in the glove box. The hand lamp is protected against overcharging and can therefore remain in its socket for an unlimited period.

However, it must be taken out if the batteries are disconnected or removed.

⚠ Always switch the lamp off before inserting it into its socket. ◀

Drink can holders

There are 2 fold-out holders for drink cans on the inside of the glove box lid.

Other storage compartments

In the compartment on the centre console and in the pockets on the doors and front edge of the front seats.

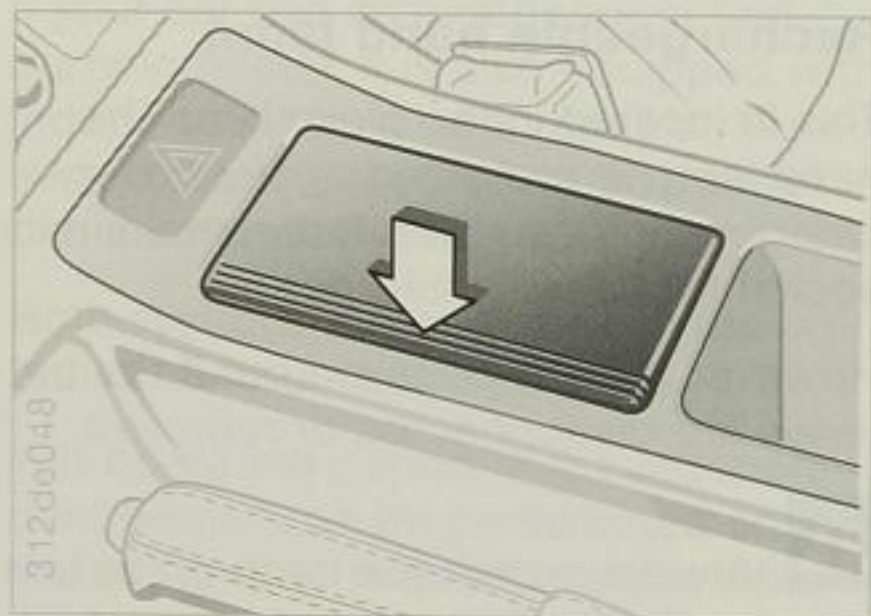

To open:
press down to the left of the lid (arrow).

To extinguish a cigarette, knock off the ash and insert a short distance only into the funnel-shaped hole.

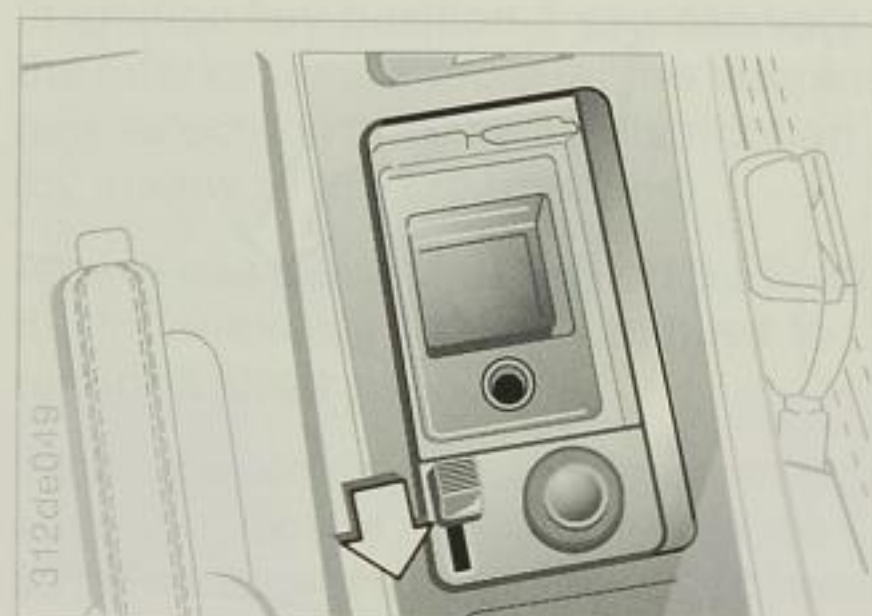

To empty:
with the ashtray open, move the lever in the direction of the arrow. The ashtray can be removed.

Cigarette lighter

Press in to operate. The cigarette lighter can be removed when it pops back out.

! Only hold the handle end of the cigarette lighter to prevent burn injuries. ◀

Cigarette lighter socket

This can also be used to power a hand lamp, a car vacuum cleaner or similar items rated at not more than approx. 200 Watts at 12 Volts. Make sure that the socket is not damaged by attempting to insert plugs of the wrong pattern.

! The cigarette lighter remains operational when the ignition key has been removed. For this reason too, children should never be left in the car unattended. ◀

Rear seat backs*

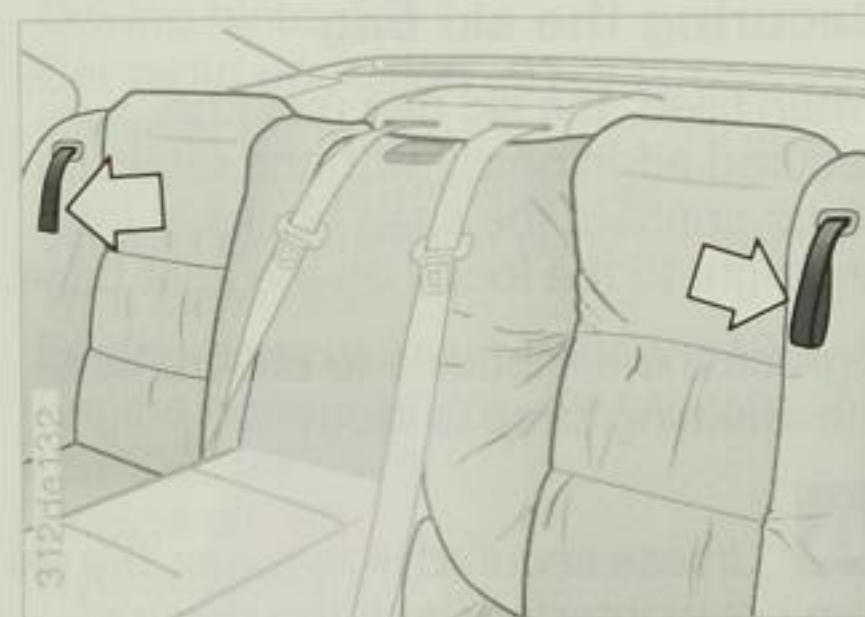

Folding rear seat backs*

So that items of luggage of moderate size can be carried, the left and right seat backs can be folded forwards after pulling the strap (arrow).

When raising the seat back, make sure that it is heard to engage in position.

Ski bag

Three or a maximum of four pairs of skis can be carried safely and without being exposed to dirt.

Together with the available length inside the car's luggage compartment, skis up to 2.10m long can be carried in the ski bag. Note, however, that when several pairs of skis are inserted, the tapered section of the bag reduces the overall carrying capacity, so that, for example, only 2 pairs of 2.10m long skis can be carried.

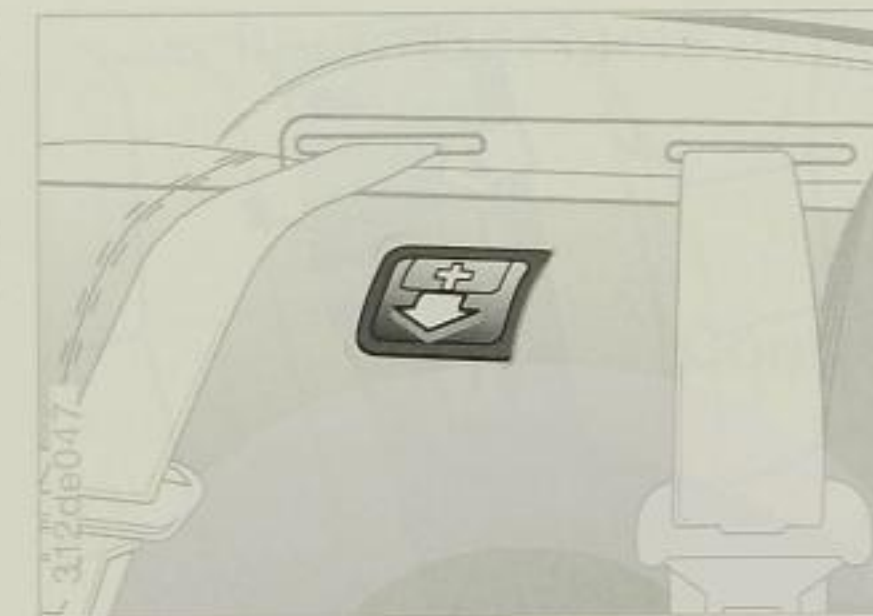

Inserting items into ski bag

Pull the release lever (arrow). Swing the centre section of the seat forwards, complete with its integral first-aid box, and lift it off.

▶ When installing the centre section again, insert it into the lower guides first and swing it back until it is heard to engage in position. ◀

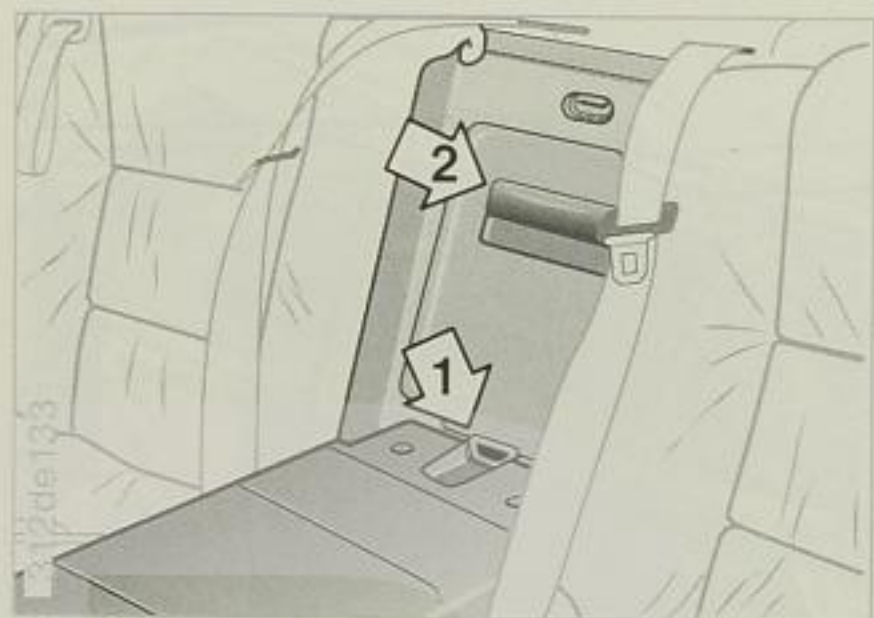

Press the release catch (arrow 1): this will release the loading flap in the luggage compartment.

Open the cover inside the car (arrow 2) and swing it down.

Lay the ski bag out between the front seats. It has a zip fastener for better access to the items inside and for use when the bag needs to be dried out.

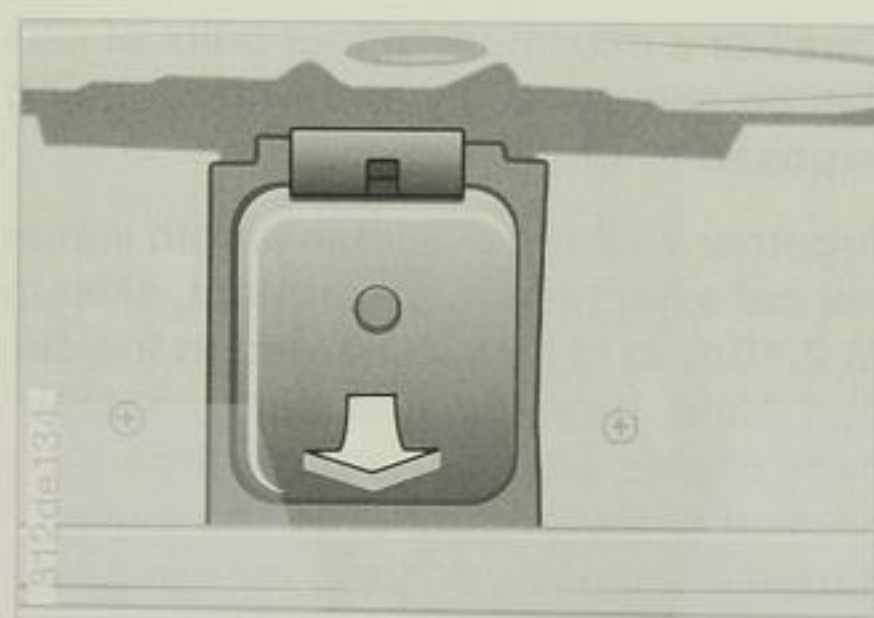

From the luggage compartment side, attach the cover flap to the underside of the rear-window shelf with the provided magnetic holder.

Make sure that the skis are clean before they are inserted into the ski bag, and that any sharp edges on them or their bindings do not damage or pierce it.

If the ski bag is not to be used for a considerable time, it must be dry before it is rolled up and stowed away.

Securing the ski bag

When filled, the ski bag must be secured additionally with the retaining strap; connect the snap hooks at left and right to the loops on the seat base.

Tighten the turnbuckle to ensure that the retaining strap is taut.



Unless secured in this way, the ski bag could interfere with the driver's control over the car or even cause injury in the event of an accident. Make sure that the ski bag does not obstruct movement of the driver. ◀

Driving hints 90
 Car radio operation 91
 Car telephone 91
 Engine compartment lid 92
 Vehicle identification number 93
 Type plate 93
 Engine compartment - BMW 840Ci 94
 Engine compartment - BMW 850Ci/850CSi 96
 Engine oil 98
 Hydraulics 100
 Hydraulics and AHK 100
 Brake fluid 101
 Coolant 102
 Washer fluid for the cleaning systems 103
 Washer jets 104
 Power steering 105
 Brakes 105
 Batteries 106
 Fuses 108
 Toolkit 109
 Warning triangle 109
 Fire extinguisher 109
 First aid box 110
 Tow-starting, towing away 110
 Tow-starting 111
 Towing away 111
 Starting with a flat battery 112
 Changing a wheel 113
 Thiefproof wheel studs 116
 Fuel filler flap 116

Luggage compartment 117
 Sliding/tilt roof 117
 Headlights 117
 Renewing wiper blades 118
 Bulb-changing 119
 Winter operation 124
 Towing a trailer 125
 Roof rack 128
 Right/left rule of the road 128
 Licensing car for use abroad 129
 ABS 129
 Active Rear Axle Kinematics (AHK) 131
 Disc brakes 132
 Tyre pressure 133
 Tread depth 133
 New tyres 134
 Interchanging wheels and tyres 134
 The correct choice 135
 Winter tyres 136
 Approved wheels and tyres 137
 Technical modifications 138

Important facts in brief

Controls

Operating hints

Care and maintenance

Technical data

Index

! Do not rest your foot on the brake pedal while the car is in motion. Even slight continuous pressure on the brake pedal could cause overheating, brake pad wear or even brake system failure.

Aquaplaning:
When driving on a wet road or one covered in slush, a wedge of water tends to form between the tyre and the road. This situation, known as aquaplaning, means that the tyre can actually lose contact completely with the road surface, so that the car can neither be steered nor braked properly. You should therefore always reduce speed on a wet road.

Rear-window shelf:
Never place hard or heavy objects on the shelf below the rear window; they could be dislodged when the car is braked heavily and endanger the occupants.

Coat hooks:
If clothing is attached to these hooks, make sure it does not obstruct the driver's view. Do not hang heavy objects from them to avoid the risk of personal injury if the car is braked suddenly. ◀

Cars with catalytic converter

The catalytic converter reduces pollutant emissions in the exhaust. Cars equipped with this must only be run on unleaded fuel. Even small amounts of lead in the fuel can permanently damage the oxygen sensor and the catalytic converter.

To ensure that the engine always operates correctly and reliably and to avoid damaging it, the following instructions should be complied with:

- ▷ Always have the specified maintenance work carried out at the stated intervals.
- ▷ Do not run the fuel tank dry.
- ▷ Switch off the engine at once if misfiring occurs.
- ▷ Never tow-start the car unless the engine is cold, or else unburned fuel may reach the catalytic converter. It is always preferable to use jumper leads from another car or a separate battery to start the car.

- ▷ Avoid any other situations in which unburned or only partially burned fuel could pass through the engine, for example: frequent operation of the starter for very short periods or repeated attempts to start if the engine does not fire. (However, switching off an engine which is running normally and restarting it again shortly afterwards is perfectly acceptable.) Running the engine with a spark plug lead detached.

If unburned fuel reaches the catalytic converter as a result of misfiring or fuel-air mixture preparation malfunctions, overheating and damage may result.

Car radio operation*

! High temperatures build up at the catalytic converter (as on all cars with this form of exhaust emission control). Make sure that no easily combustible material (for example hay, leaves, grass etc.) comes into contact with the hot exhaust system when the car is being driven, is idling or is parked. If this material were to ignite and cause a fire, very severe injuries or damage could result.

Do not remove the heat shields from the exhaust system or apply underseal to them. ◀

For adjustments to your car radio and correct operations of its controls, please refer to the accompanying operation manual.

The reception and reproduction quality of a mobile radio installation depends on its distance from the chosen transmitter and on aerial alignment.

Interference from high-tension overhead wires, as well as buildings and natural obstructions, may cause noise and signal deterioration which cannot be avoided even if the interference suppression systems of the vehicle are in good working order.

Solar activity, fog, rain and falling snow also affect radio reception.

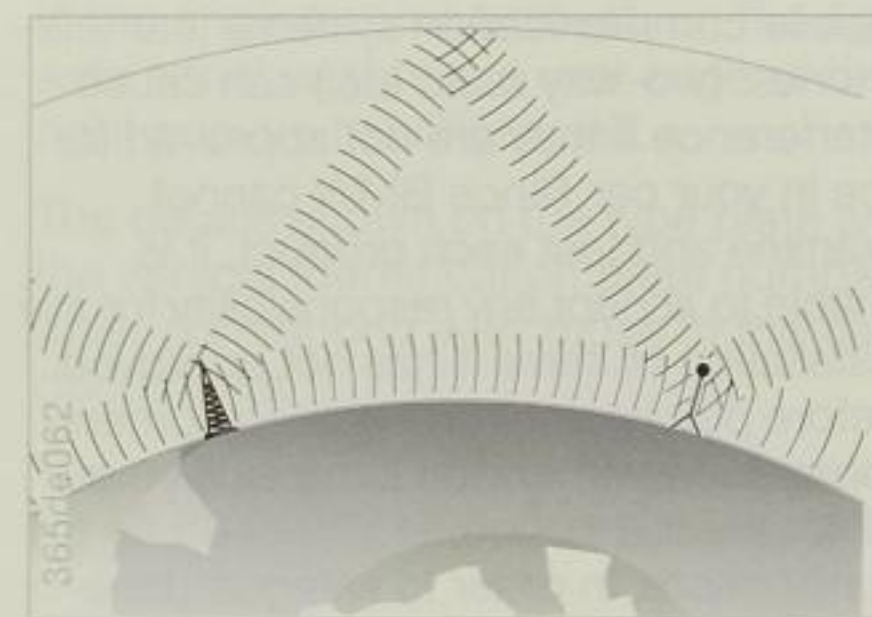

The MW, LW and SW wavebands can be heard a long way from the transmitter, because the signals spread out both along the ground and through the atmosphere, reflected by the ionosphere.

VHF (FM) reception provides far higher listening quality than any of the AM wave bands. However, the range of a VHF transmitter is limited to about 100 kilometres, since the signals travel only by line of sight.

Car phones not recommended by BMW or other mobile phones could cause radio interference. This takes the form of a low-pitched humming in the loudspeaker system.

Mobile communication systems (car telephones, two-way radio etc.) can cause interference if they are not approved for use in your car. Since BMW cannot examine and test each product, it is unable to accept any responsibility for the installation of items it has not approved. Before purchasing any such equipment, you are recommended to consult your BMW service station.

Furthermore, in order to safeguard the operating reliability of your BMW, do not operate any in-car telephones or other mobile radio equipment with an aerial inside the car or with an aerial which is not attached to the outside of the car.

Detach the telephone aerial before driving on to a car-carrier train.

Engine compartment lid

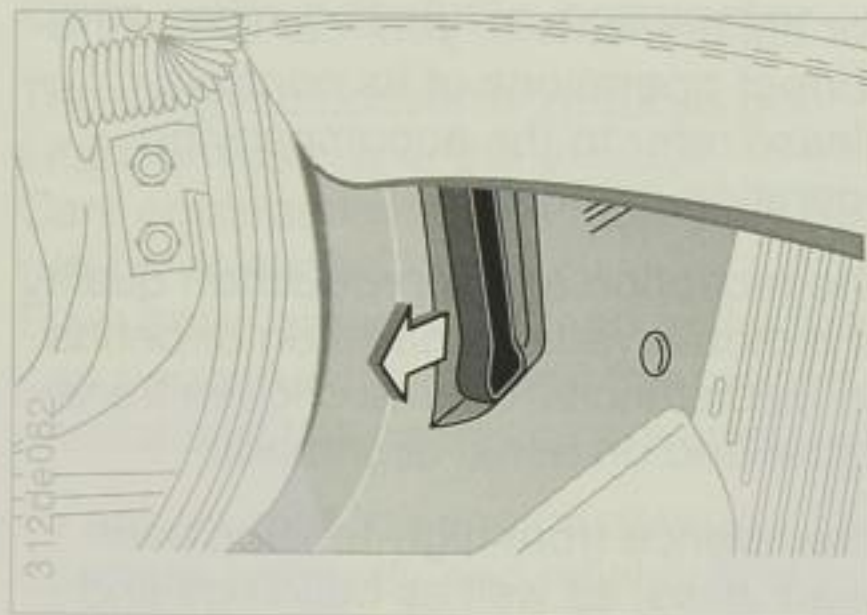

Releasing

Pull the lever on the left under the instrument panel.

! Switch off the engine and allow it to cool down before undertaking any work inside the engine compartment. Always disconnect the batteries before any work is commenced on the electrical system, particularly inside the engine compartment. Careless handling of parts or materials when working on the car represents a personal safety hazard. Please study and comply with the relevant instructions. If you are not familiar with the regulations which could be applicable in a specific situation, you are recommended to entrust the work to a BMW Service station. ◀

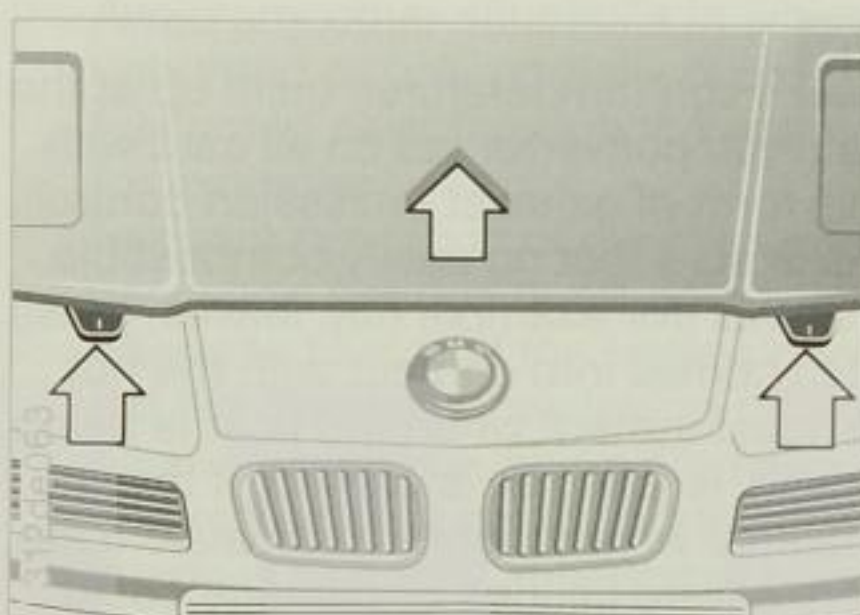

To open

Press the two sliding catches (arrows) to the rear and raise the lid.

Engine compartment light

This comes on when the engine compartment lid is raised if the main lights of the car are on.

Engine compartment lid

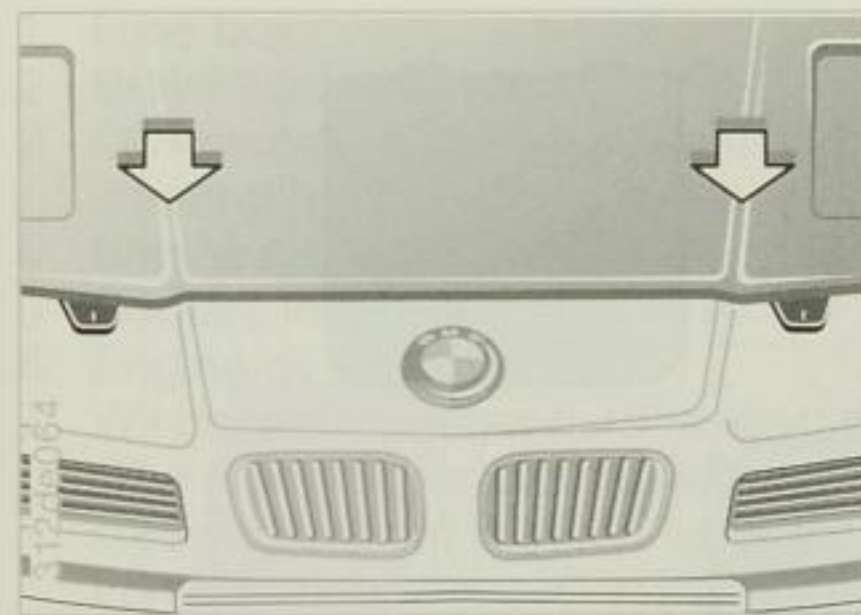

To close

Press the lid down evenly on both sides until the catches are heard to engage.

! When closing the engine compartment, keep hands clear of the apertures for the pop-up headlights, or injury may result. Should you notice while driving the car that the engine compartment lid is not properly secured, stop at once and close it correctly. ◀

Vehicle ID number

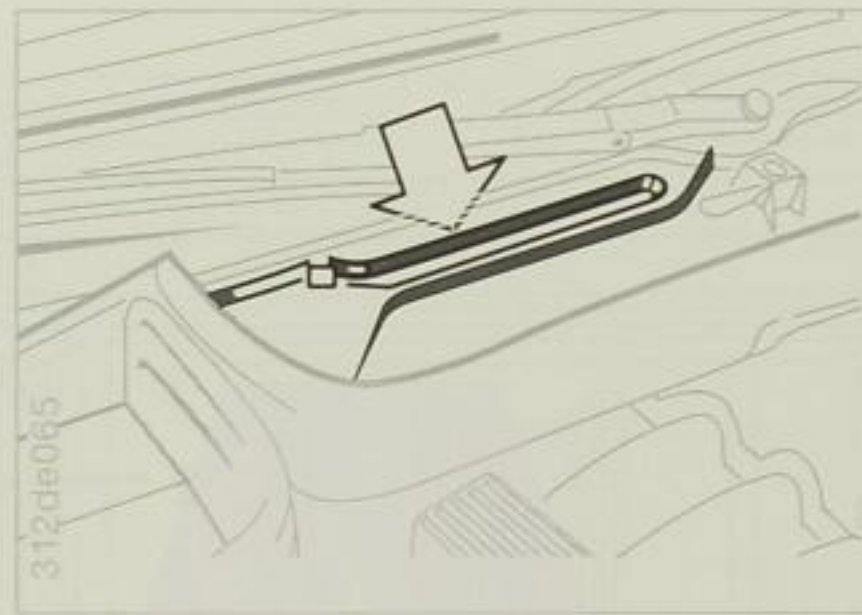

Vehicle identification number

This is located in the engine compartment, behind a gusset plate and next to the right windscreen wiper pivot shaft (arrow); it may also appear on the top of the instrument panel, at the left.

Type plate

In the engine compartment, on the right side panel next to the rear edge of the right pop-up headlight unit.

The details shown on the type plate and the vehicle identification plate number must correspond with those in the car documents.

The car data are needed as a reference for all queries, checks and spare part orders.

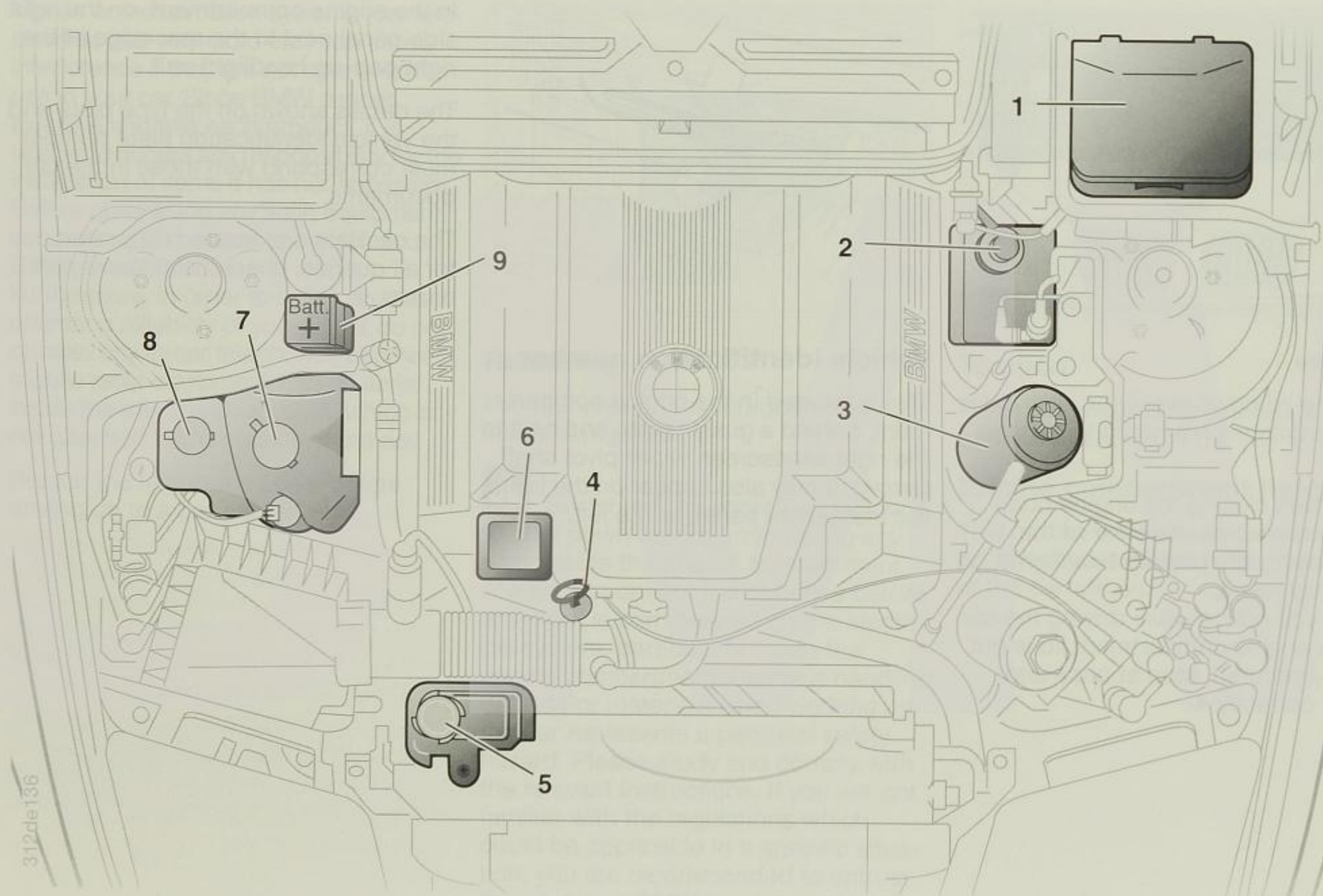

- 1 Fuse box
- 2 Brake fluid reservoir
- 3 Oil reservoir for brake system and steering hydraulics
- 4 Engine oil dipstick
- 5 Coolant level equalizing tank
- 6 Engine oil filler cap
- 7 Windscreen washer fluid reservoir (The reservoir for the headlight cleaning system is in the luggage compartment)
- 8 Reservoir for intensive cleaning system
- 9 Connection for jump starting

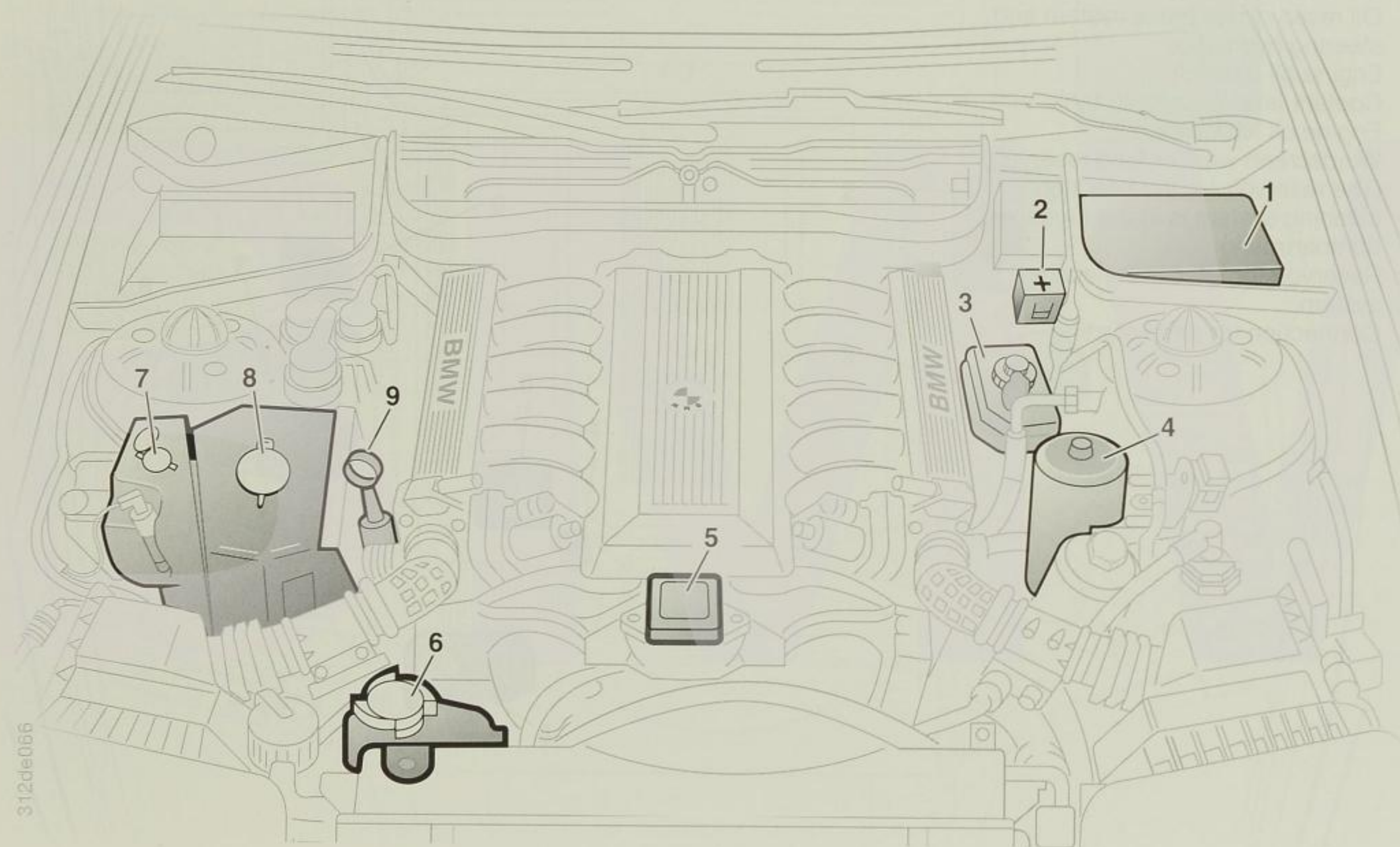

312de066

- 1 Fuse box
- 2 Connection for jump starting
- 3 Brake fluid reservoir
- 4 Oil reservoir for brake system and steering hydraulics
- 5 Engine oil filler cap
- 6 Coolant level equalizing tank
- 7 Reservoir for intensive cleaning system
- 8 Windscreen washer fluid reservoir (The reservoir for the headlight cleaning system is in the luggage compartment)
- 9 Engine oil dipstick

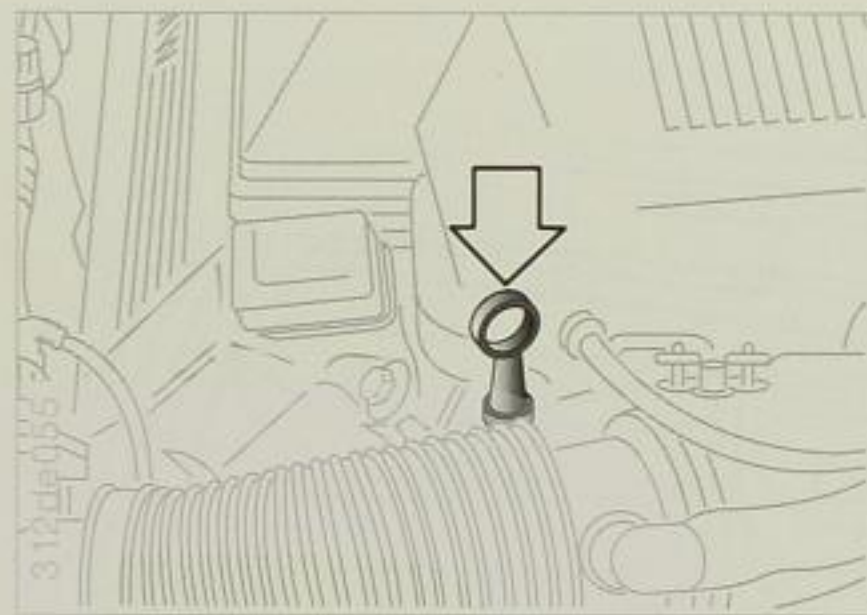

Engine - checking oil level

Like fuel consumption, engine oil consumption depends on driving style and operating conditions.

The oil level should therefore be checked regularly, approximately every 1000km (approx. 600 miles), or sooner if the car has been driven hard. The car should stand on a flat, level surface when checking.

Optimum measuring accuracy: before a cold engine is started.

If the engine is already at its normal operating temperature, wait a short time so that the oil can drain back in the sump (for instance while refuelling).

Push the dipstick fully down into its tube.

The oil level must be between the two marks on the dipstick.

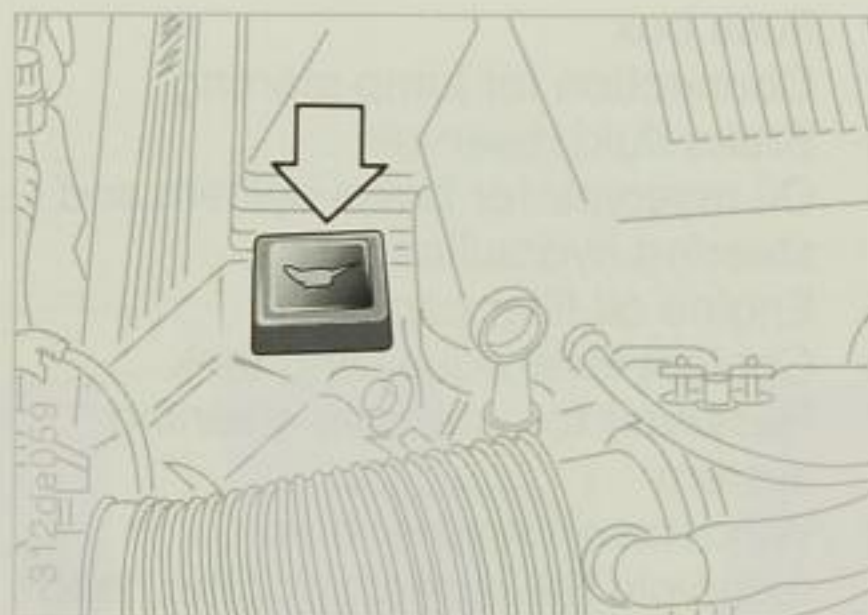

Engine - adding engine oil

Do not add oil until the level has fallen almost to the lower mark on the dipstick. However, the oil level must not fall below the minimum level mark.

The space between the two dipstick marks represents approx. 1 litre of oil. Never add oil beyond the upper dipstick mark. Adding too much oil will harm the engine and, because it will be burned off more rapidly, incorrectly imply that engine oil consumption was too high.

BMW engines are designed not to need separate additives in the engine oil and adding these substances could even be harmful in certain circumstances. The same applies to the manual gearbox or automatic transmission, the final drive and the power steering.

Engine oil specifications

The grades of engine oil to be used are exclusively governed by the CCMC or API specification.

Required quality stages:

Preferred:	Also permitted
CCMC-G4 CCMC-G5	API SG API SH
CCMC-G4/PD2 CCMC-G5/PD2	API SG/CD API SG/CE API SH/CD API SH/CE

When disposing of used oil, please comply with environmental protection laws.

Recommendation:

Always have oil changes carried out by the BMW Service station.

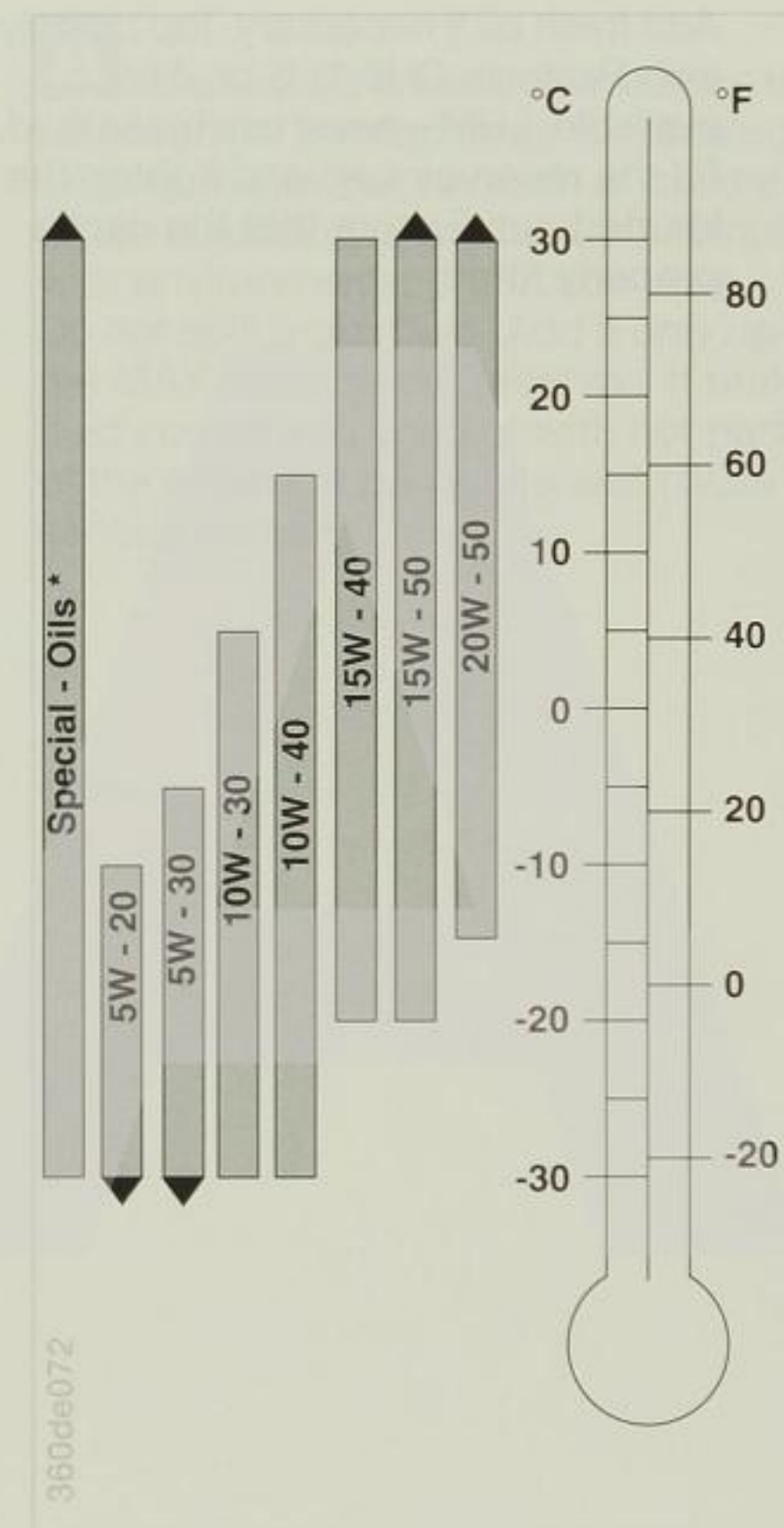

* Engine oils to CCMC-G5 or CCMC-G5/PD2 specification, individually approved by BMW

Viscosities

(The liquid density of the oil, as shown by the SAE classification)

The choice of SAE grade depends on the average air temperature at the time of year.

The correct SAE grade is shown in the chart.

Note that the temperature limits indicated for the various SAE grades can be departed from for brief operating periods.

 In laboratory tests, prolonged contact with used oils has caused cancer. For this reason, always wash affected skin areas thoroughly with soap and water after work. Keep oils, greases etc. out of the reach of children and in vessels marked with a suitable warning. ◀

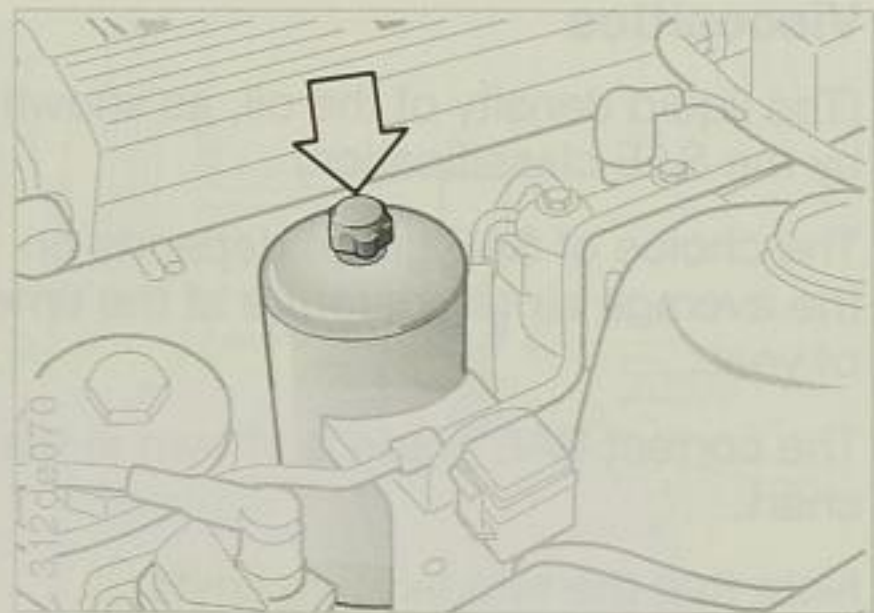

- ▷ Add fresh oil if necessary. Top up only with Pentosin CHF 11 S or, if not available, LHM – never use brake fluid.
- ▷ Fit the reservoir cap and tighten the knurled nut. Ensure that the cap is properly fitted.

Checking oil level for brake system and steering hydraulics

- ▷ With the engine at a standstill, unscrew the knurled nut and take off the reservoir cap.
- ▷ Depress the brake pedal about 10 times until the oil level in the reservoir no longer rises and increased resistance is felt at the pedal.
- ▷ Check oil level: it must be about 20mm below the rim of the reservoir.



Oil for brake system, steering hydraulics and AHK*

(AHK = Active Rear Axle Kinematics)

If the display "CHECK P.A.S. FLUID" appears in the MID, consult a BMW Service station.

In an emergency:

- ▷ With the engine at a standstill, unscrew the knurled nut and take off the reservoir cap.
- ▷ 0.25l Pentosin CHF 11S or, if unavailable, LHM.
- ▷ If the display remains visible in the MID, add a further 0.25l.
- ▷ Fit the reservoir cap and tighten the knurled nut. Ensure that the cap is properly fitted.



Fill to the upper (MAX) mark. The level can be seen from the outside.

BMW Service stations are familiar with the factory-approved brake fluids (DOT 4).

- ▷ **!** Brake fluid is hygroscopic, that is to say it absorbs moisture gradually from the air. To ensure that the brake system remains fully operational, the brake fluid must be renewed every 2 years by a BMW Service station. ◀

In addition, please comply with the instructions given on page 108.

- ▷ **!** Brake fluid is toxic and attacks the paintwork of the car. Keep it in sealed original packs, out of reach of children. When disposing of brake fluid, comply with environmental protection laws. Do not spill brake fluid. Add it only up to the MAX mark on the reservoir. If brake fluid comes into contact with hot parts of the engine, it can ignite and cause serious burns. ◀

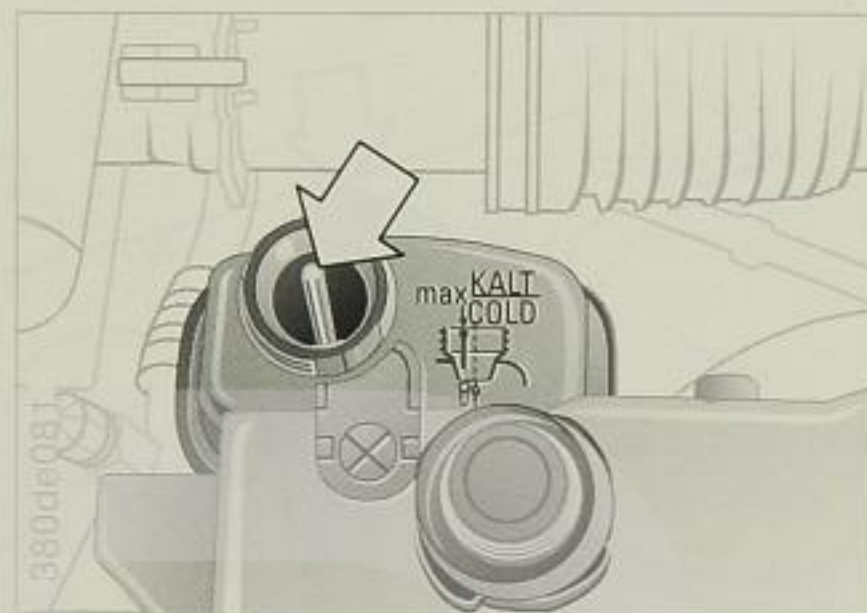

Coolant level with engine cold (approx. 20°C):

Unscrew the equalizing tank cap.

The coolant level is correct if the top end of the red float rod is on a level with the top edge of the filler pipe (see arrow in illustration or sketch on equalizing tank).

The coolant consists of water to which a long-life antifreeze and corrosion inhibitor has been added. The 50:50 mixing ratio must be maintained all the year round to ensure protection against corrosion. No other additives are needed.

Renew the coolant every 3 years.

Adding coolant to system:

Open the cap on the equalizing tank only when the engine has cooled down. The pointer of the coolant thermometer must be in the blue zone, or else there will be a risk of scalding.

- ▷ Turn the cap anti-clockwise slightly until the excess pressure can escape, then remove it.
- ▷ Slowly add coolant up to the correct level—do not overfill!

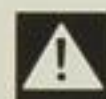

Never add coolant when the engine is hot. To avoid the risk of possible subsequent damage, use only factory-approved long-life antifreezes and corrosion inhibitors containing no nitrites or amino compounds. Every BMW Service station is familiar with these products. Antifreezes and corrosion inhibitors are toxic. Store them only in the original packs, out of reach of children.

Long-life antifreeze and corrosion inhibitor contains the flammable component ethylene glycol. Take care not to spill long-life antifreeze and corrosion inhibitor on hot parts of the engine, otherwise it can ignite and cause serious burns. ◀

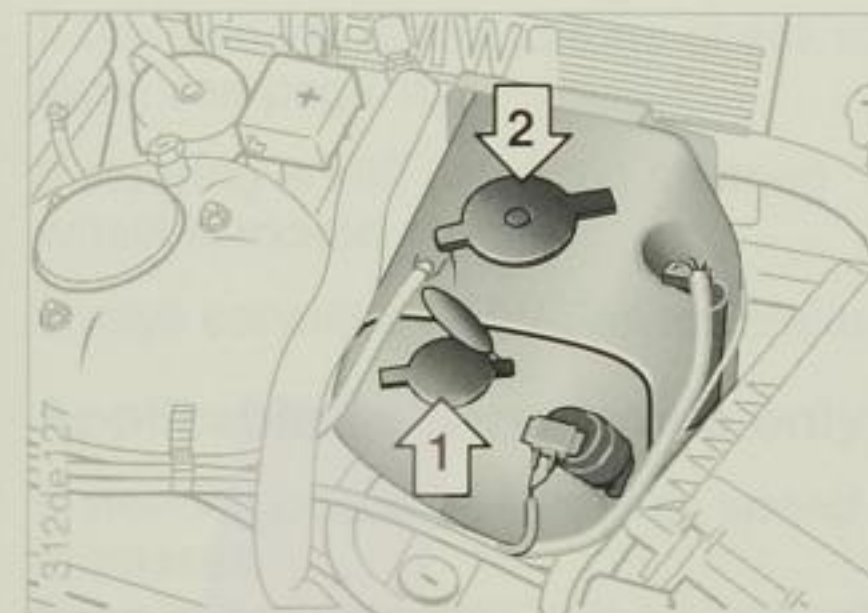

Intensive cleaning system (1) Small cap

Capacity approx. 1.0litre (1.8 pints). Fill with intensive cleanser (for frost protection down to approx. -27°C, available from BMW Service).

Windscreen washer(2) Large cap

Capacity approx. 2.5litres (4.4 pints). Fill with water and add antifreeze if required (comply with the manufacturer's instructions).



It is advisable to mix the washer fluid before adding it to the systems. ◀

Combined windscreen and headlight cleaning system*

Add fluid at the filler pipe in the luggage compartment cutout (see next picture).

On vehicles with AHK (Active Rear Axle Kinematics) the front reservoir can also be reached directly for filling.

Capacity approx. 9.0litres (15.8 pints), or approx. 6.0l (10.5 pints) on vehicles with AHK.

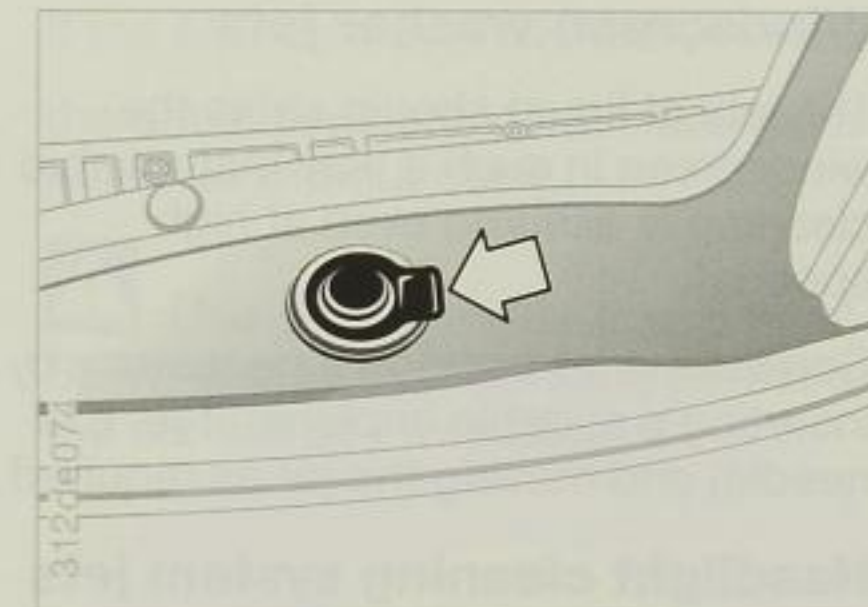

Fill with water and add antifreeze if required (comply with the manufacturer's instructions).



Only add cleaning agents and antifreeze after diluting with water, e. g. never in their concentrated form, to prevent causing any damage to the rear light. ◀



Do not operate washers when the reservoirs are empty. ◀

Windscreen washer jets

The jets of liquid should strike the windscreen in such a way that reliable cleaning is assured even at high speeds.

Correct the jet position if necessary by inserting a suitable implement (e. g. a needle) and moving the jet as required.

Headlight cleaning system jets

Have these jets adjusted by a BMW Service station if necessary.

Power steering

If the steering is stiff to turn: check oil level, see page 100.

If steering is stiff when the steering wheel is moved rapidly:

always consult a BMW Service station.

Applicable to Servotronic only*

If steering becomes lighter as speed increases:

there is a malfunction in the electronic control system.

 If the power assistance should fail, greater effort will be required at the steering wheel. ◀

Brakes

If the warning light for the brake and steering hydraulics comes on and "LOW BRAKE FLUID" is displayed on the MID:

brake fluid has been lost from the system causing pedal travel to increase.

Failure of one brake circuit

Brake pedal travel increases and higher pedal pressure is needed.

The car can still be braked effectively with the intact brake circuit.

However, you should take the car to a BMW Service station without any delay if a brake system malfunction occurs.

If the warning light flashes and the MID displays "BRAKE ASSIST INACT.", the following faults may have occurred:

- ▷ If increased brake pedal pressure is needed: loss of reservoir pressure, no brake servo action
- ▷ If the power steering becomes heavier to turn: loss of system pressure, no power assistance
- ▷ If brake pedal pressure is higher and the steering heavier to turn: the hydraulic pump has failed or the V-belt has broken.

If the MID displays "BRAKE LININGS": the brake pads are worn. Have them renewed without delay.

 Use only brake pads approved by BMW, or else the operating permit for the car will be invalidated. ◀

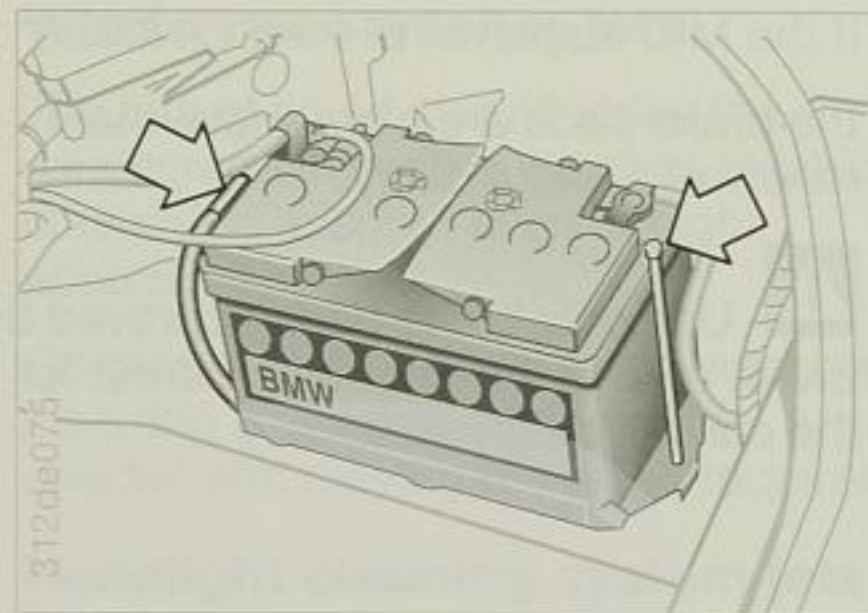

The two batteries are located behind the side trim panels in the luggage compartment. There is a positive terminal in the engine compartment to which a jumper lead can be connected if necessary (see page 112).

The batteries are maintenance-free to German DIN 43539/2 standard, that is to say their acid content normally lasts for the lifetime of the battery.

If the acid level drops too low, for instance if the car is used for lengthy periods in a hot climate, top up with distilled water (not acid).

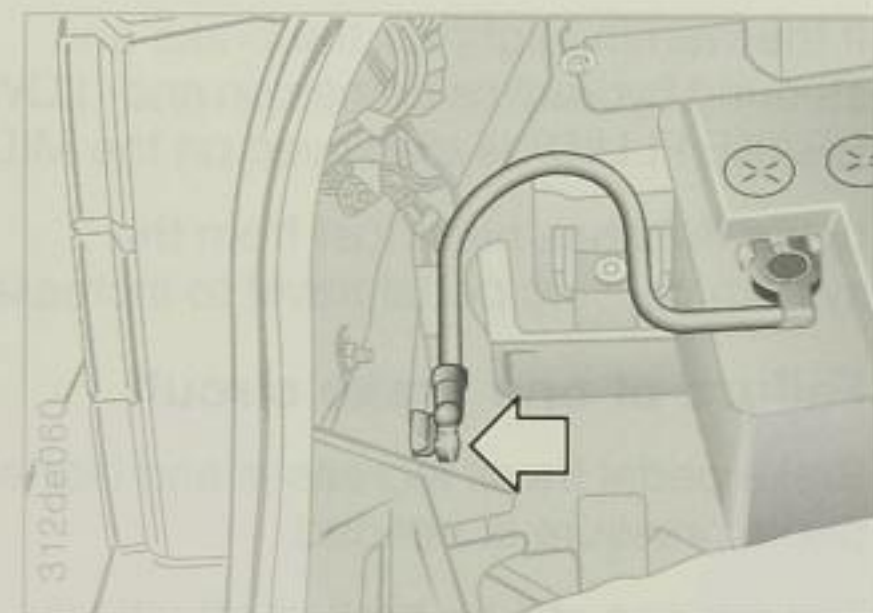

Acid level: up to the "MAX" mark on the outside of the battery in each cell (approx. 5mm above the tops of the plates of the cells).

Keep the tops of the batteries clean and dry.

! Never disconnect one of the batteries only. Before removing, either detach the negative terminals at both batteries or their common earth (ground) strap at the body (see arrow). ◀

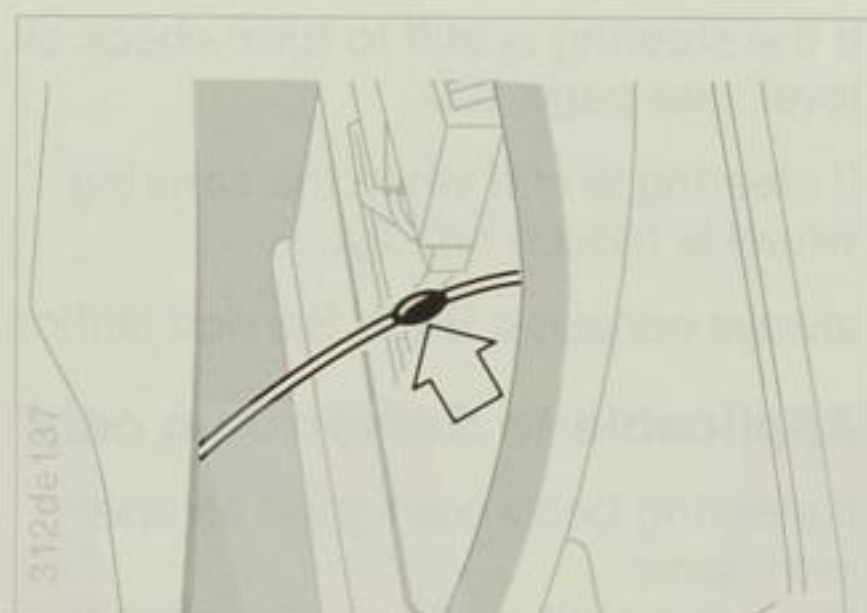

Before detaching the right luggage compartment trim, first disconnect the plug connection for manual fuel filler flap release at the pull wire (arrow).

Batteries

- i** Read the following instruction before undertaking any work on the batteries:
- 👁️** Always wear eye protection. No particles containing acids or lead should be allowed to come in contact with eyes, skin or clothing.
- ⚠️** Battery acid is highly toxic. Wear protective gloves and suitable glasses or goggles. Do not tilt the battery, otherwise acid could leak out through the gas vents.
- 🚫** Keep children away from acid and batteries.
- 🚫** Avoid fire, sparks, or naked flames close to the battery. Do not smoke. Try to avoid sparks when using cables or from other electrical equipment. Avoid short-circuits. Never short-circuit the battery terminals, as the resulting arc could cause severe injury.
- ⚠️** When the batteries are charged, a highly explosive gas mixture is emitted and can detonate.



If any splashes of acid reach the eyes, rinse them out immediately for some minutes with clean water and consult a physician without delay. Neutralize acid spillage on the skin or clothes immediately with soap and rinse off with plenty of water. If acid has been swallowed, consult a physician immediately.



To protect the battery case from ultraviolet rays, keep batteries away from direct daylight. As batteries which have run flat could freeze, store in a place where there is no risk of frost damage.

Never detach the battery leads when the engine is running, or else an overvoltage will occur and damage the car's electronic equipment beyond repair. First disconnect the negative terminal(s), then the positive terminal(s) and take off the degassing tank at the side. Unscrew the battery retaining clamp. When installing, make sure that the batteries are held securely; connect the positive terminal(s) then the negative terminal(s).

Charging the battery

Recharge the batteries in the car only with the engine stopped. It is easiest to recharge both batteries by way of the positive terminal and earth (ground) point in the engine compartment. Starting with a flat battery: see page 112. To avoid short-circuits, disconnect both negative terminals from each battery or detach the common earth (ground) cable before starting any work on the electrical system.

If the car is to remain out of use for more than four weeks, disconnect the batteries from the car's electrical system by detaching the negative battery post clips.

If the car is to remain out of use for more than six weeks, remove the batteries, recharge them and store them in a cool place (but protected against frost). Recharge the batteries at least every three months, or they will be rendered useless. Every time a battery goes flat, particularly if left in this state for any length of time, its operating life is reduced.

If one of the batteries is defective or has to be renewed, two new batteries of identical make and type must always be installed.



Hand old batteries back to an authorized collection point or a BMW Service station. When filling, always carry or store batteries upright. Protect batteries against falling over when in transit.



Periods of time in which the car's battery is disconnected are disregarded by the service interval indicator when calculating the need for brake fluid renewal.

Take any such periods into account with regard to the two-yearly brake fluid renewal interval, and do not wait until the clock symbol lights up. ◀

Fuses

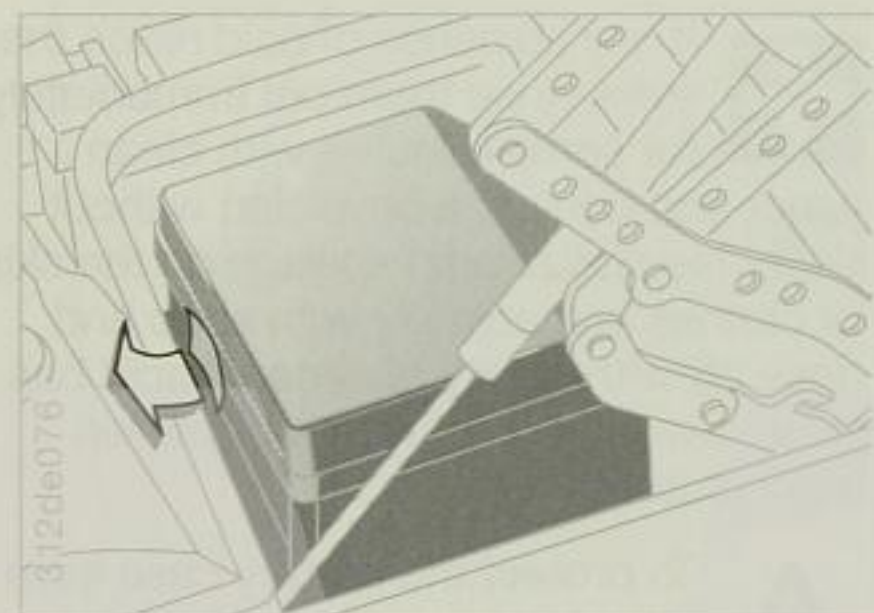

If an electrical consumer fails, switch it off and check its fuse.

The fuse box (electrical distribution box), with spare fuses, relays and plastic pincers, is on the left inside the engine compartment.

- ▷ Press the retaining flap in and lift off the cover.
- ▷ Use the plastic pincers to remove the blown fuse from its holder.
- ▷ A blown fuse can be recognized by its melted metal wire.

There are more fuses behind the left trim panel in the luggage compartment. On cars with Check Control and a trailer tow hitch, there are additional fuses for the trailer lights in the trailer module in the luggage compartment, behind the left side trim. The fuse for the permanently positive line is located next to the battery, in a separate fuse box.

A list of fuses with ratings in Amps and details of the electrical consumers supplied is given on each fuse box cover.



Always renew blown fuses; never attempt to repair them with unsuitable materials. ◀

If a fuse blows several times in succession, ask the BMW Service station to trace and rectify the fault.

Toolkit

Under the luggage compartment lid, accessible after unscrewing the wing bolt.

Warning triangle*

Space is provided in the toolkit to accommodate the warning triangle in an accessible location.



Please note that in certain countries you are required by law to carry a warning triangle in the car. ◀

Fire extinguisher*

There is a mounting on the driver's seat.

To ensure full operating reliability, have the fire extinguisher examined by a Service station authorized by the manufacturer every 2 years.

If these Service stations are not listed on the extinguisher or in any documentation available to you, please consult a local trade directory or the "Yellow Pages" of the telephone service to obtain the address.

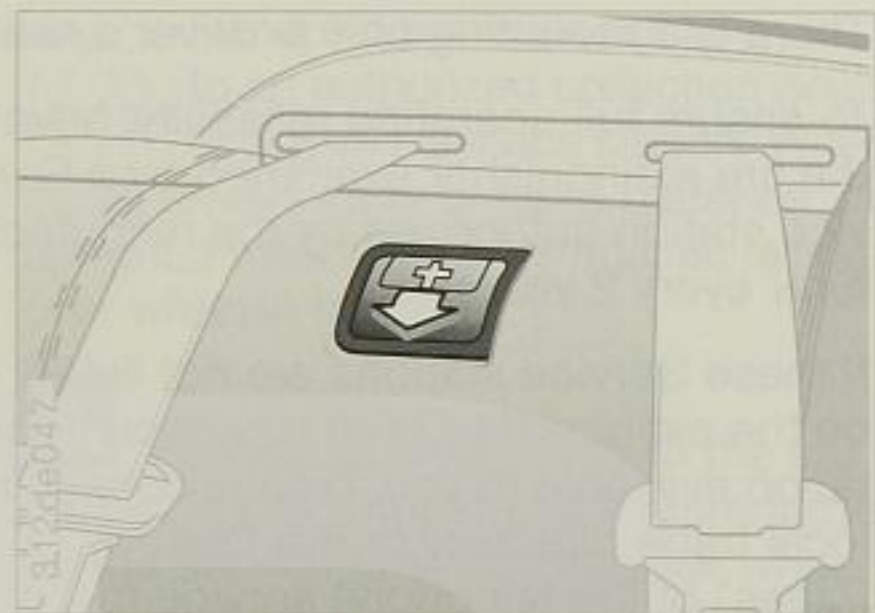

Between the back seats. Pull the catch (arrow) down and swing the cover forwards.

! Some of the items in the first-aid box have a limited useful life. Please check the contents regularly and replace life-expired items in good time. Replacements can be obtained from any pharmacy. Comply with legal requirements concerning the need to carry a first-aid kit in the car. ◀

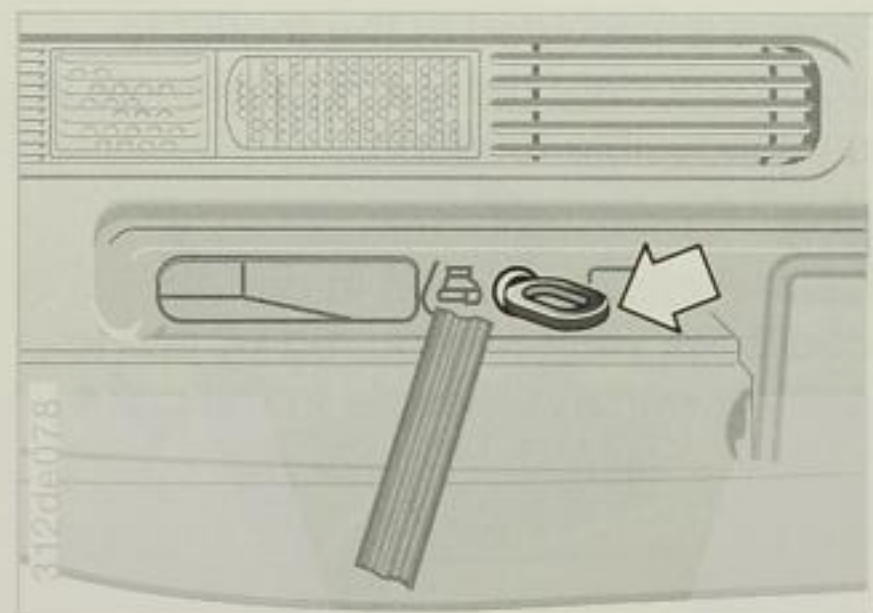

The screw-in towing eye is kept in the toolkit and must always be carried. It can be attached at the front or rear of the car as required.

! Always screw in the towing eye fully. ◀

Screwing in at front

Pull the left side of the cover out and remove it.

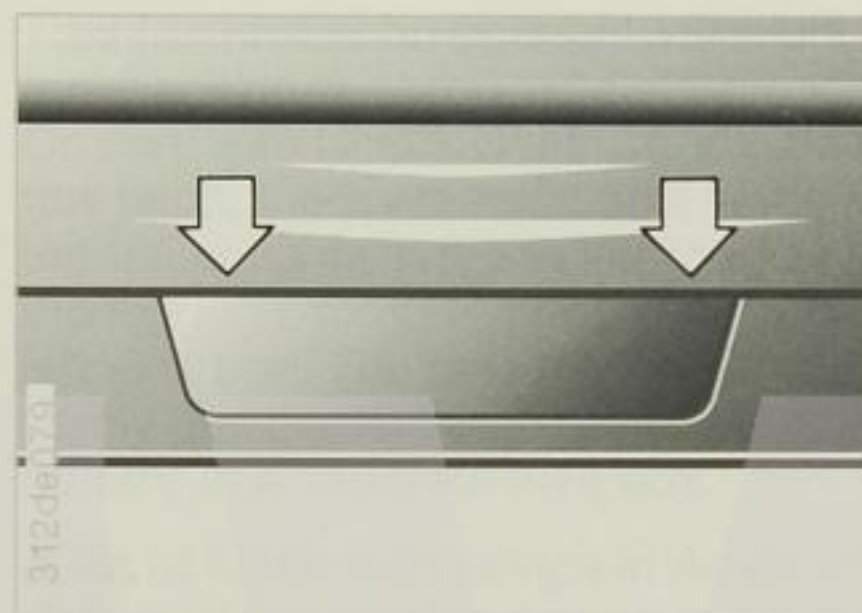
**Screwing in at rear**

Press the cover down at its left and right ends by inserting a screwdriver into the upper joint line (see arrows in picture).

On cars with a trailer tow hitch, the threaded hole is next to the ball head mounting.

To insert the cover, place it in the guide at the bottom and press in at the top.

For towing, either a rigid towbar or a nylon rope or strap should be used (the latter have the advantage of being resilient, so that peak loads are avoided).

Using a towbar:

The towing eyes of both vehicles should be on the same side.

If the towbar has to run at an angle, note the following:

- ▷ Clearance may be restricted when turning corners.
- ▷ If the towbar runs at an angle, lateral forces will be generated (these may be critical on a slippery surface).
- ▷ To compensate for towbar angularity, the two vehicles cannot always be driven one directly behind the other.
- ▷ If the towing vehicle's brakes are applied, the other vehicle may over-run it or skid sideways.

! The towed vehicle should not be heavier than the towing vehicle. ◀

Cars with catalytic converter should only be tow-started if the engine is cold. It is always preferable to use jumper leads from another car or a separate battery to start the car.

- 1 Switch on the hazard warning flashers. (Comply with national regulations regarding their use.)
- 2 Turn the ignition key to position 2.
- 3 Select third gear.
- 4 Keep the clutch pedal down. When the car is moving, gradually release the clutch pedal. When the engine has fired and is running, depress the clutch pedal again.
- 5 Switch off the hazard warning flashers.

Have the cause of the starting problem traced and rectified by a BMW Service station.

Cars with automatic transmission

These cars cannot be tow-started.

For starting with a flat battery, see next page.

- 1 Turn the ignition key to position 1 so that the brake lights, turn indicators, horn and wipers can be operated.
- 2 Switch on the hazard warning flashers. (Comply with national regulations regarding their use)

If the electrical system of the car has failed, display a warning notice to the rear or place the warning triangle in the rear window.

▶ Please make sure that the ignition key is turned to position 1 even if the electrical system has failed to prevent the steering wheel from locking. ◀

Cars with automatic transmission

- ▷ Move the selector lever to N.

Maximum towing speed: 50km/h

Maximum towing distance: 50km

! When the engine is not running, there is no power assistance and the brake servo is out of action. The steering and brakes will require extra effort to operate. ◀

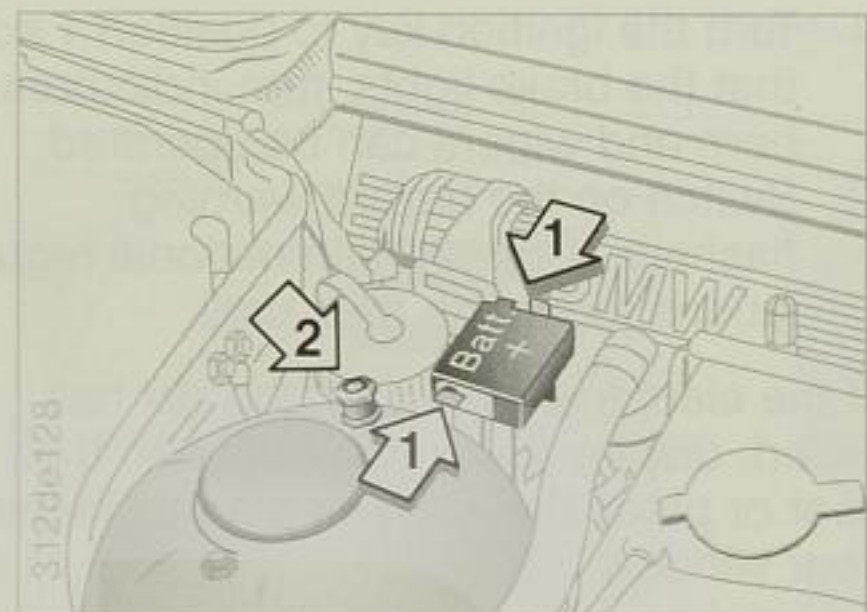

Do not use spray products sold as an aid to starting.

If the car's own battery is flat, the engine can be started by using two jumper cables from another vehicle's battery.

! Touching any live components when the engine is running can result in a fatal electric shock. ◀

Do not depart from the procedure described below, or else personal injury could result or one or both vehicles could be damaged.

- 1 Check that the other vehicle has a 12 Volt battery of approximately the same capacity (65Ah). This should be printed on the battery.
- 2 Do not disconnect the flat battery from the car's electrical system.
- 3 The bodies of the two vehicles must not touch, or a short circuit could result.
- 4 First connect the positive terminal of the other car's battery with one of the jumper leads to the positive pole in the BMW's engine compartment (this has a protective cover marked "+" which can be removed by pulling the flap (BMW 850Ci, 850CSi) or by pulling the two flaps at the side (BMW 840Ci - see left picture, arrow 1).

Then connect the batteries' negative terminals. First attach the jumper lead to the negative terminal of the other vehicle's battery or to the other car's engine or body earth and then to the engine or body earth (nut on spring strut dome, see picture, arrow 2) of your own car.

! When connecting jumper leads, including when assisting other vehicles, please work in the sequence stated above in order to prevent sparks occurring at the battery. ◀

- 5 If the second vehicle's battery is not well charged, run that vehicle's engine. Start your own car's engine in the usual way and leave it running. Before detaching the jumper leads from your BMW, switch on your car's lights, heated rear window and heater blower (at maximum speed) to ensure that the voltage reaching the consumers from the regulator is not too high. Then disconnect the jumper leads in the opposite order (negative pole first, then positive pole).

Have the battery recharged (depending on the cause of the fault).

Changing a wheel

Apply the handbrake and select either reverse or 1st gear (manual gearbox) or automatic transmission position P.

If you suffer a puncture during a journey, protect the car by switching on the hazard warning flashers and, if necessary, setting up the warning triangle or a flashing warning light at a sufficient distance to the rear. Comply with national legislation in these respects.

To avoid rattling noises later, note how the various tools are attached to the car and replace them in precisely the same positions afterwards.

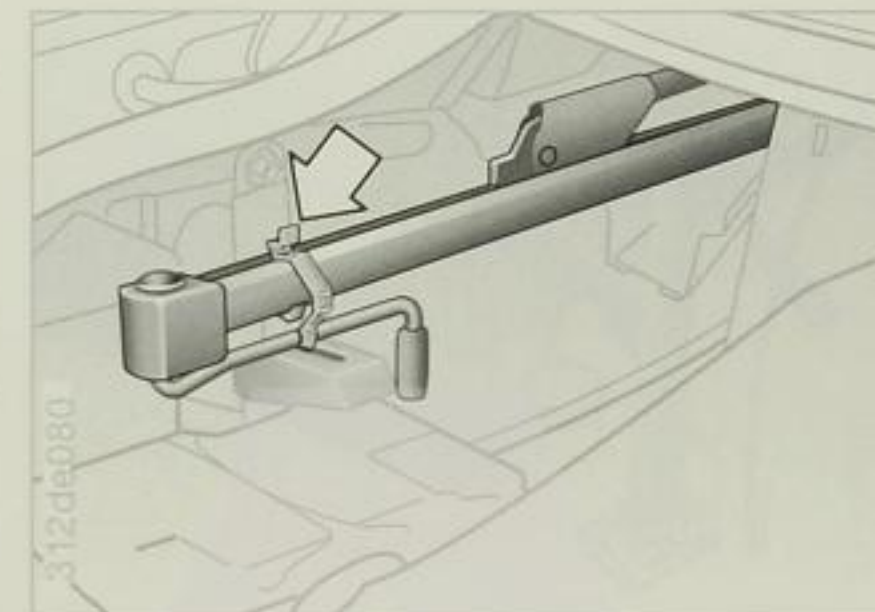

Jack

In the luggage compartment, behind the left trim.

Pull the trim away at the pre-formed cut-out. Release the spring clip (arrow) and take out the jack.

After use, lower the jack fully, place its base in the holder and press it forwards.

Spare wheel and hexagon adapter

These are both under the mat in the luggage compartment. Take out the mat.

Take off the black hexagon adapter, unscrew the wing nut by hand and remove the wheel.

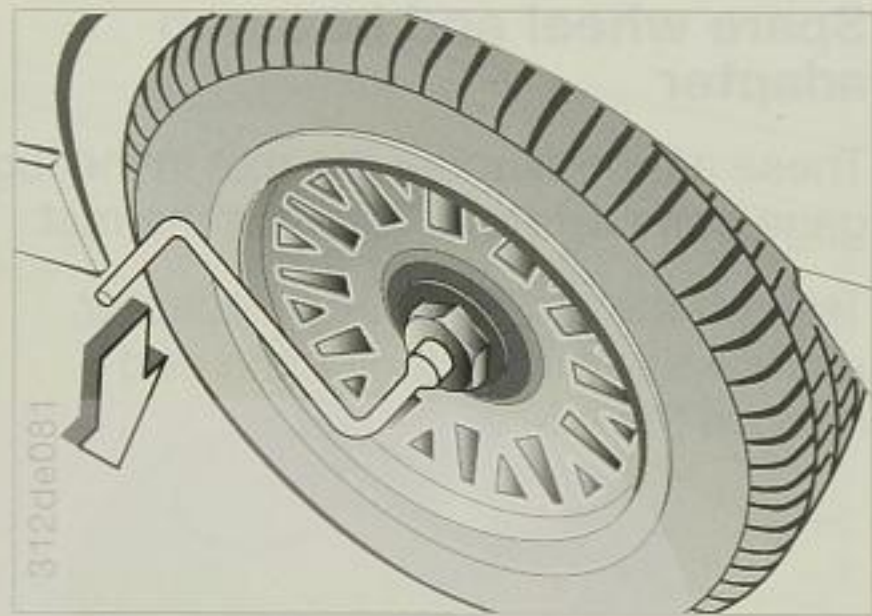
**Wheel changing procedure:**

- 1 Take off the wheel stud cover by applying the hexagon adapter and stud wrench to it and turning to the left. For thiefproof wheel studs, see page 116.
- 2 Slacken the wheel studs by half a turn.
- 3 Press in and remove the jack attachment socket cover at the appropriate point of the car (arrow).
- 4 Insert the jack fully into the socket and position it so that the base is resting firmly on the road.
- 5 Raise the car body with the jack until the wheel to be changed is clear of the road.

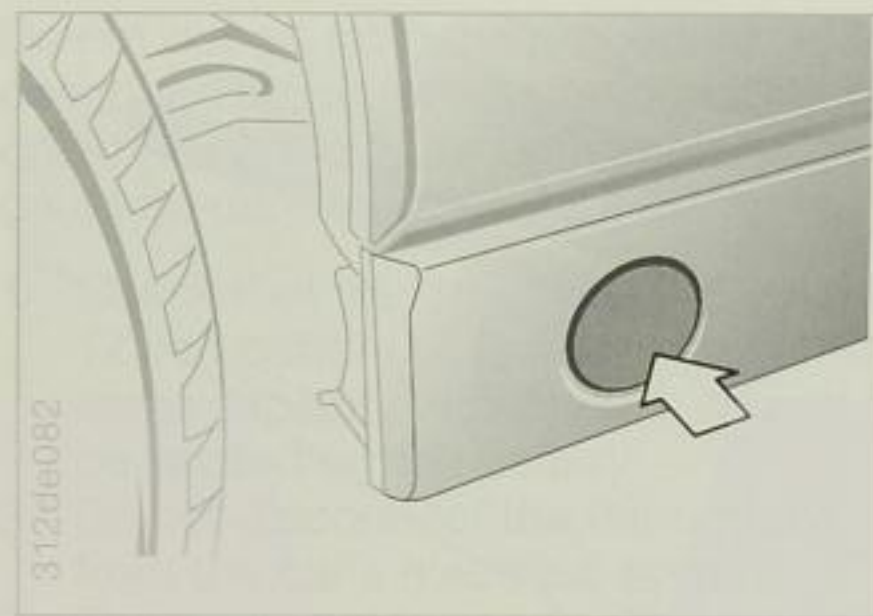

Use the jack only for wheel changing. Never attempt to lift another type of car or any other heavy object with it, as this could lead to accidents and personal injury. Do not lie under a jacked-up car – a very severe or fatal injury could result. ◀

- 6 Take out the wheel studs and remove the wheel.
- 7 Insert the centering pin from the car's toolkit into one of the threaded holes, with the plastic cap in position on it.
- 8 Offer up the new wheel, insert at least two of the studs at opposite points and take out the centering pin.



For light alloy wheels with turbine styling or with a directional turbine-style cover, please note:

These wheels or covers are asymmetric, and therefore intended to rotate in one direction only. The spare wheel matches the wheels on the right side of the car; the spare wheel for the BMW 850CSi does not have a cover.

The wheel illustrated is on the left side of the car.

If a puncture has occurred, the BMW 850Ci's spare wheel can also be fitted on the left side of the car, but a wheel which rotates in the intended direction should be fitted instead as soon as possible.

The wheel cover can only be fitted by a BMW Service station or a specialist workshop.

Wheel stud wrench and centering pin

In the toolkit underneath the luggage compartment lid.

265/40 ZR 17 rear tyres

In the event of a puncture, it may be necessary to use the spare wheel with a 235/45ZR17 tyre at the rear. Although this wheel can be used entirely satisfactorily in all load and speed ranges, a tyre of size 265/40ZR17 should be fitted in its place as soon as possible.

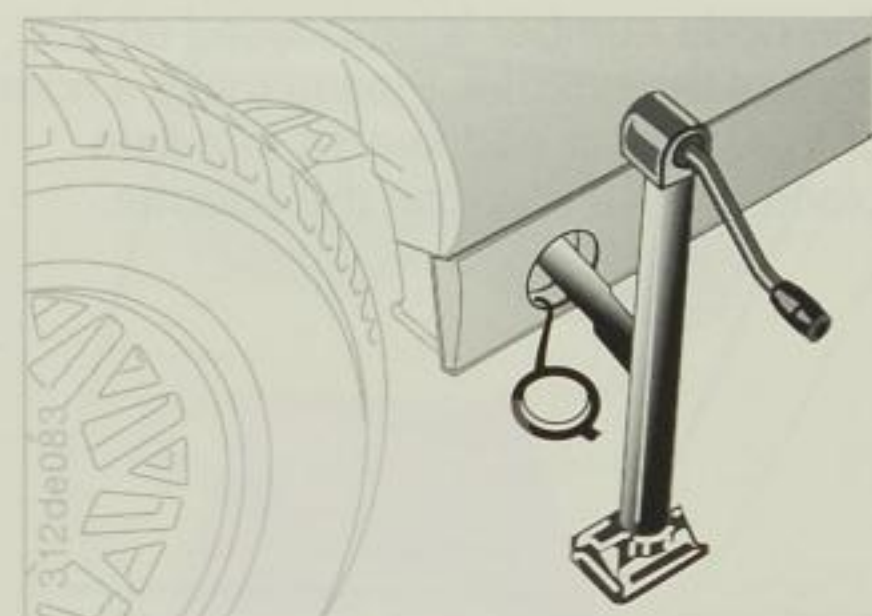

- 9 Screw in the remaining wheel studs and tighten them all in a crosswise pattern.
- 10 Lower the car, remove the jack, insert the jack attachment point cover with the flap at the bottom and press it in at the top.
- 11 Tighten the wheel studs fully, working in a crosswise pattern.



For safety reasons, the wheel studs should be checked with a calibrated torque wrench to ensure that the specified tightening torque of 100Nm (74 lb.ft.) has been reached. If a new wheel (for instance the spare wheel) is fitted for the first time, check the tightening torque again after the car has covered 1000km (about 600 miles). ◀

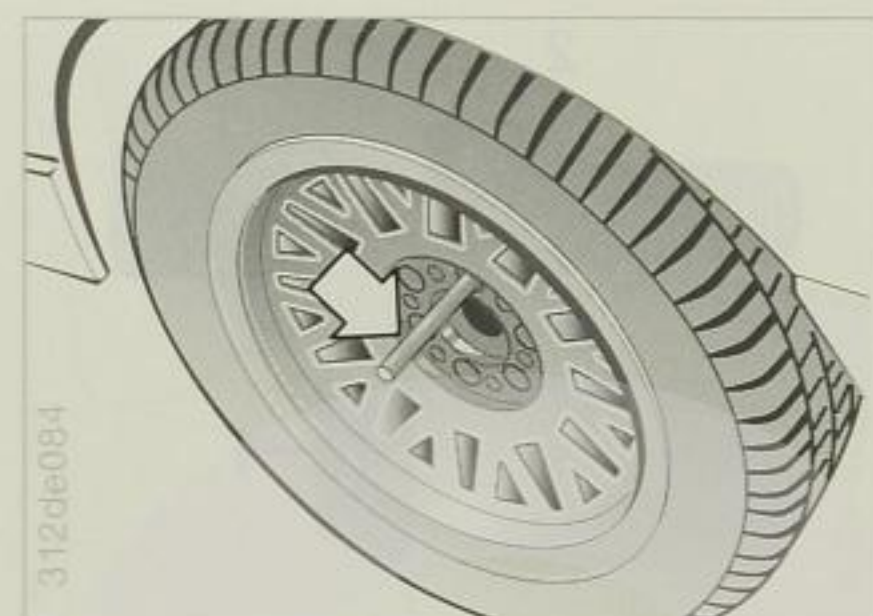

- 12 Centre the wheel stud cover and attach. Push it on and turn to the left or right until wheel cap locks into place. Cross-spoke wheels: align with the arrow marked on the wheel stud cover with the line marked on the wheel and push on the wheel cover.

When replacing a wheel in the spare wheel well, make sure that the central rod in the well is not damaged.

If your car is equipped with wheels other than Original BMW light-alloy wheels, make sure that the correct wheel studs are used.

Have the flat or defective tyre repaired or replaced as soon as possible, and the wheel and new tyre balanced.

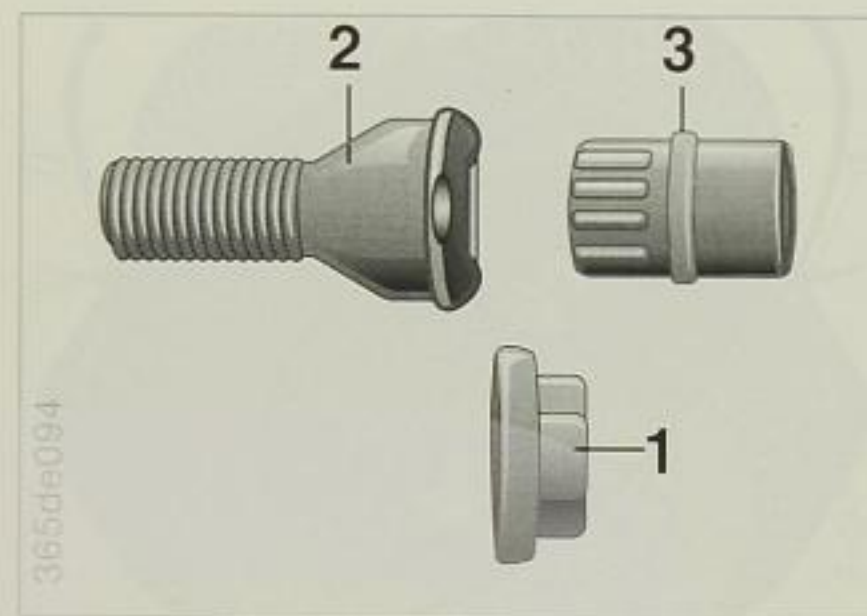

- 1 Stud cap (not for wheels with wheel stud cover)
- 2 Wheel stud for adapter
- 3 Adapter (supplied in toolkit)

To remove:

- 1 Turn the cap (1) slightly to the left with the wheel stud wrench and remove it.
- 2 Take adapter (3) from the car's toolkit and insert it into the wheel stud.
- 3 Unscrew the wheel stud (2).

After inserting and tightening the wheel stud again, remove the adapter and press on the stud cap.

The code number is embossed on the front of the adapter. Please make a note of this number and keep it in a safe place in case you lose the adapter.

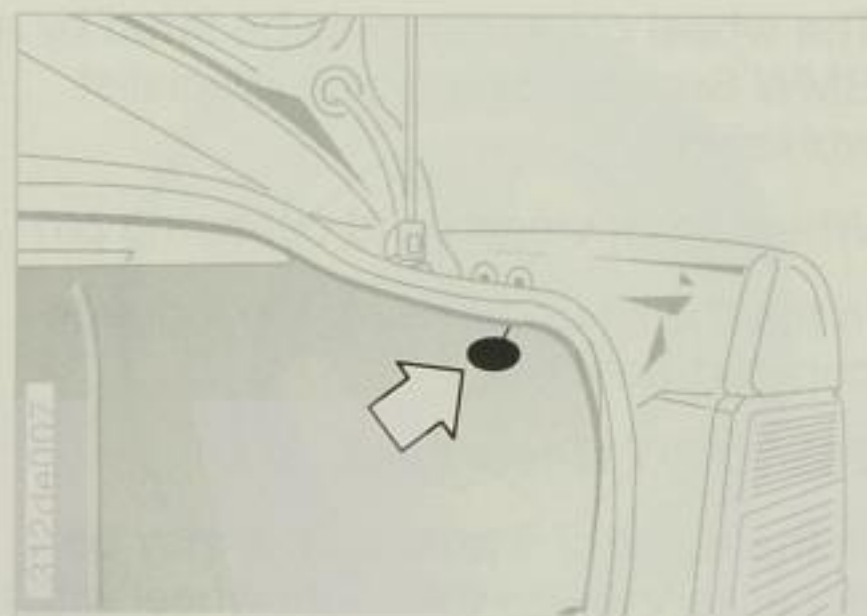
Fuel filler flap**Manual release**

Take the pull wire (arrow) out of the luggage compartment trim and pull it to the rear.

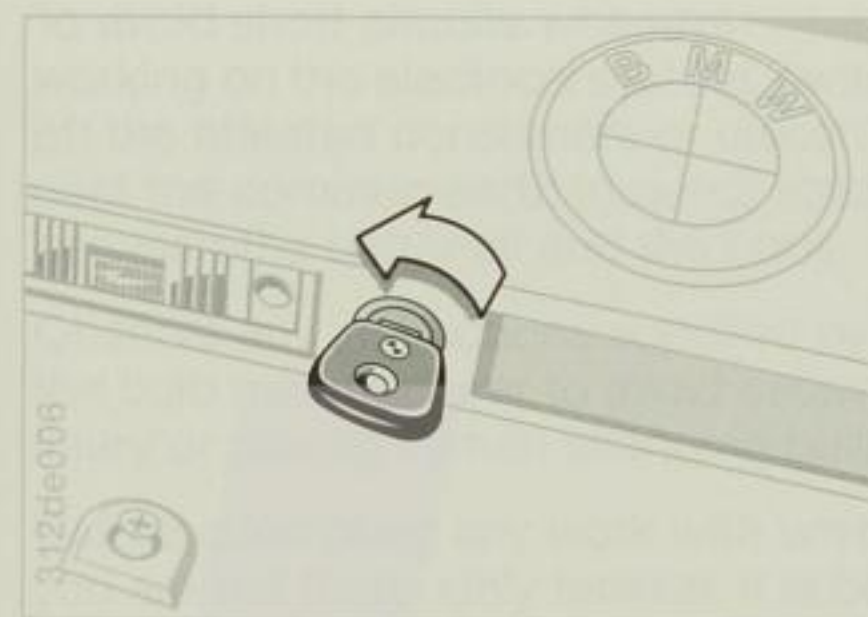
Luggage compartment**Manual release**

- 1 Insert the master key into the lock next to the release button.
- 2 Turn the key and remove it again in the position in which it was inserted.
- 3 Press in the lock barrel in.

The luggage compartment locks again as soon as it is closed.

▶ If the thiefproofing system has been activated, the alarm will be triggered if the luggage compartment is opened manually. ◀

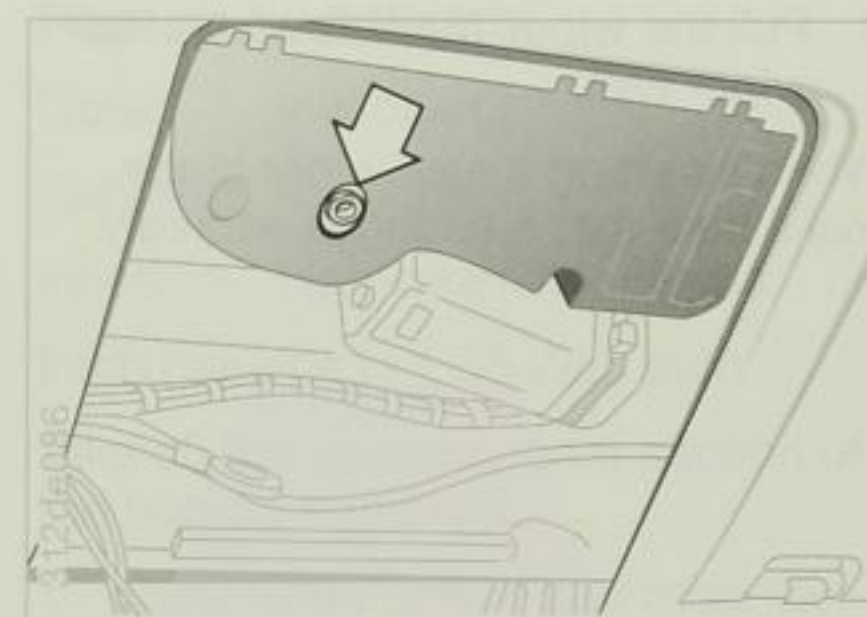
Sliding/tilt sunroof**Manual release**

- 1 Press out the interior light by inserting a screwdriver into the cut-out.
- 2 Take off the cover.
- 3 Use the Allen key from the car's toolkit to move the roof in the desired direction.

To ensure that the sunroof operates correctly after repair or restoration of the power supply, it has to be re-synchronized:

- ▶ Press the electric operating switch or keep it slid forwards for 12 seconds. (Do this only when synchronizing is necessary, not at any other time.)

Have the fault rectified by a BMW Service station without delay.

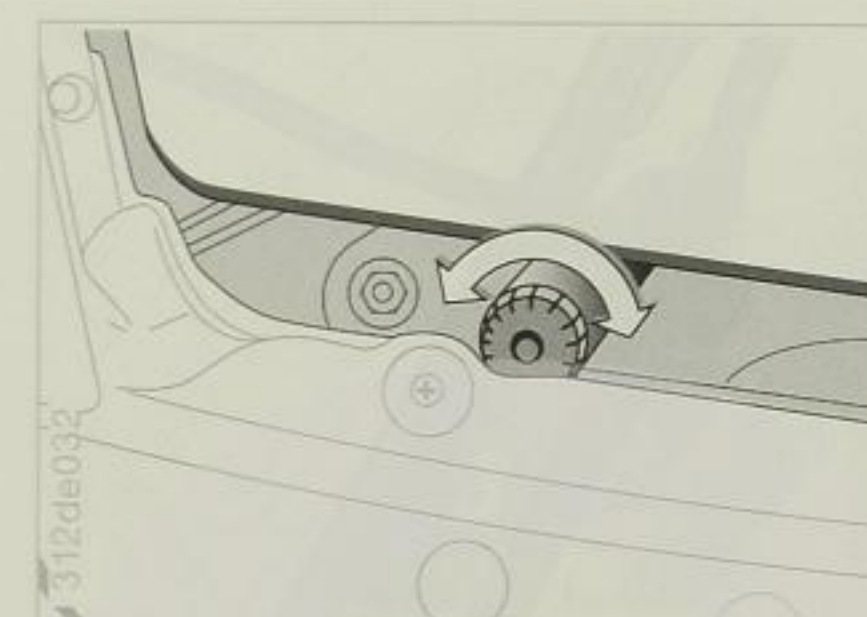
Headlights**Manual release**

- 1 Open the engine compartment.
- 2 Turn the knurled knob to the left or right until the headlight unit is fully extended or retracted (and no longer moves when the knurled knob is turned several times).

Have the fault rectified by a BMW Service station without delay.

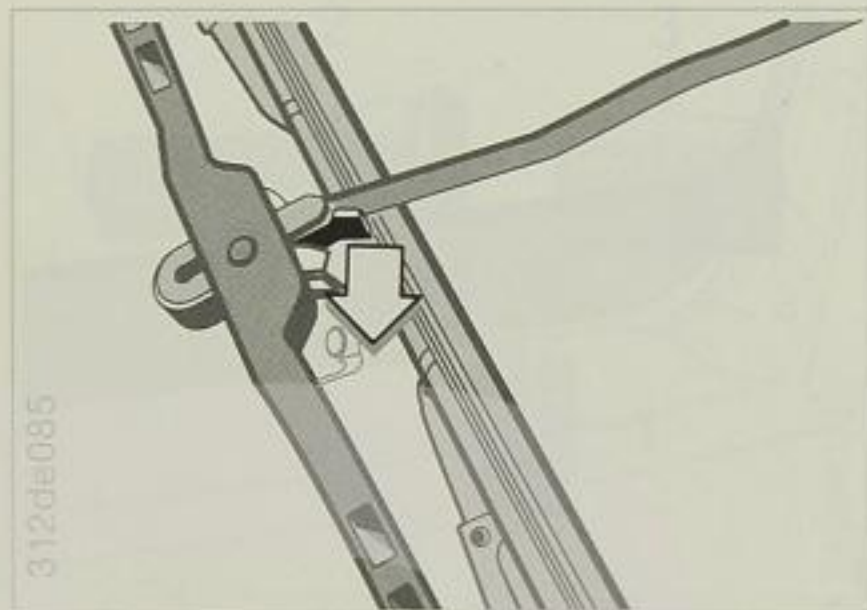

- 4 Pull the wiper blade towards the wiper arm.

When inserting a new wiper blade, make sure that it engages securely.

- 1 Move the wipers to the fold-out position; switch on the ignition. Move the wiper control lever to position 1 (intermittent wipe). Switch the ignition off again between wiper movements. The wipers will then move up to an almost vertical position.
- 2 Lift the wiper arm away from the glass and hold it securely.
- 3 For the driver's side wiper, pull the outer spring keeper first and then the inner one (arrow) until the wiper blade is released. There is only one spring keeper on the passenger's side wiper.

To avoid short circuits whenever working on the electrical system, switch off the affected consumers or disconnect the common earth (ground) strap between the batteries and the body.

Observe any instructions supplied by the bulb manufacturer to avoid causing injury or damage when changing bulbs.

Before attempting any work with which you are not thoroughly familiar, it is better to entrust it to your BMW Service station.

Do not touch the glass of new bulbs with bare fingers. Use a clean cloth, paper tissue or similar instead or handle bulb only by its base.

A box containing spare bulbs is available from your BMW Service station.

Pop-up headlights

Outer: low beams

Centre: fog lights

Inner: high-beam headlights

Each has one H 1, 55 Watt bulb.

Take off the painted upper section of the pop-up headlight:

- 1 Remove the screw and raise the upper section slightly.
- 2 Push the upper section forward and take it off.

 When attaching the painted upper section of the pop-up headlight, make sure that it is seated correctly – particularly at the front mountings – and that the toggle fastener is properly closed by rotating it through a quarter of a turn. ◀

**Low beam headlight (1) and fog light (2)**

- 1 Pull the flap and take off the cover.
- 2 Pull off the plug.
- 3 Release the spring wire clip.
- 4 Change the bulb.

When attaching the cover again, press it on uniformly all around.

**High beam headlight (3)**

- 1 Turn the cover to the left and take it off (bayonet catch).
- 2 Pull off the plug.
- 3 Press the spring wire clip and disconnect it.
- 4 Change the bulb.

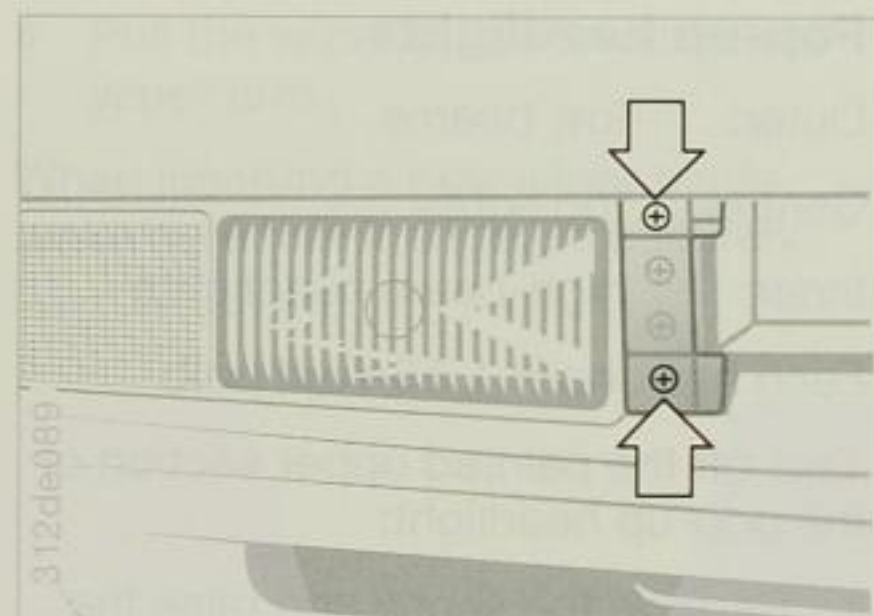
**Lighting strip**

Inner: high beams/headlight flasher
H1, 55 Watt bulb

Center: side and parking light/daytime
driving light*
21/5 Watt bulb

Outer: Left/right flashing turn
21 Watt bulb

Removing:

- 1 pull the grille out forwards.
- 2 Take out the two Phillips-head screws (arrows).
- 3 Pull the lighting strip out forwards, pivoting it slightly towards the outside of the car and removing it from the guide.

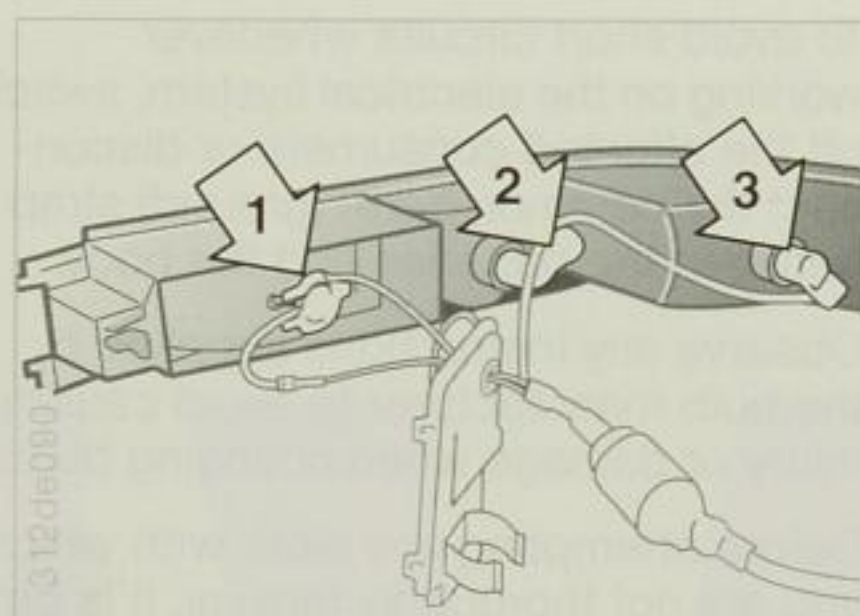
**High beam/headlight flasher (1)**

- 1 Press the cover away from its fastenings with a screwdriver.
- 2 Disconnect the cable.
- 3 Release the spring wire clip and change the bulb.

Side and parking light/daytime driving lights (2)

- 1 Turn the bulb holder to the left and remove it.
- 2 Press the bulb in slightly and turn it to the left to remove.

Flashing turn indicator (3)

- 1 Press the bulb holder in slightly and turn to remove.
- 2 Remove the bulb in the same way.

Side turn indicator repeater

5 Watt bulb

- 1 Press the light unit forward at its rear edge, and remove it to the side.
- 2 Press the bulb in slightly, turn to the left and remove.

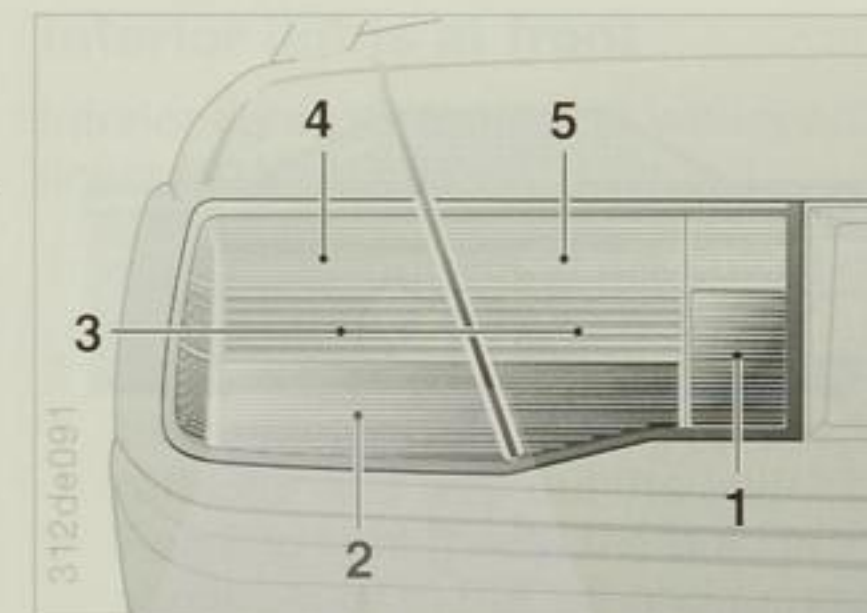
**Rear lights**

- | | | |
|---|----------------------------|--------|
| 1 | Rear fog light | red |
| 2 | Brake light | red |
| 3 | Rear lights and reflectors | red |
| 4 | Turn indicator | yellow |
| 5 | Reversing light | white |

Rear lights: two 5 Watt bulbs

Other lights: 21 Watt bulb

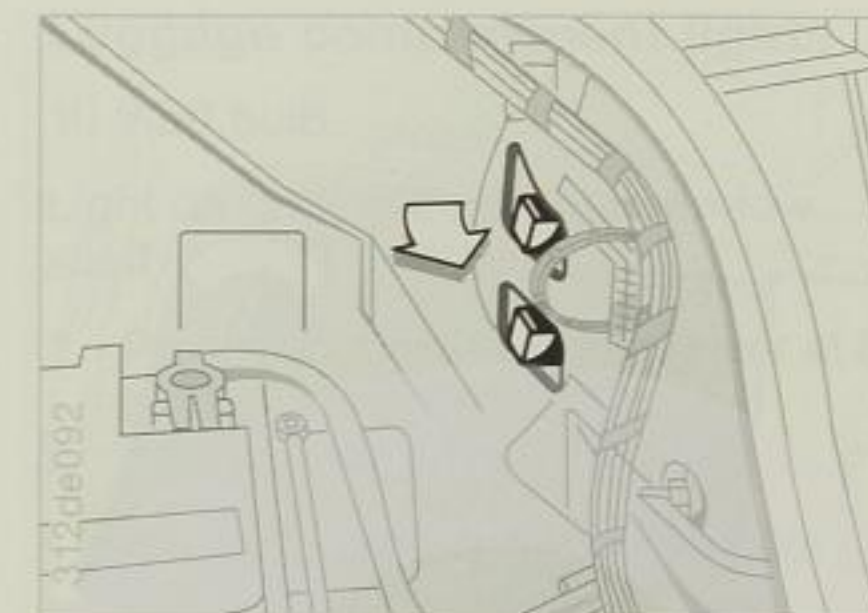
**Lights at side:**

- 1 Take off the trim by holding the pre-formed grip area and pulling.
- 2 Press the appropriate bulb holder in slightly and turn to the left to remove.
- 3 Remove the bulb in the same way.

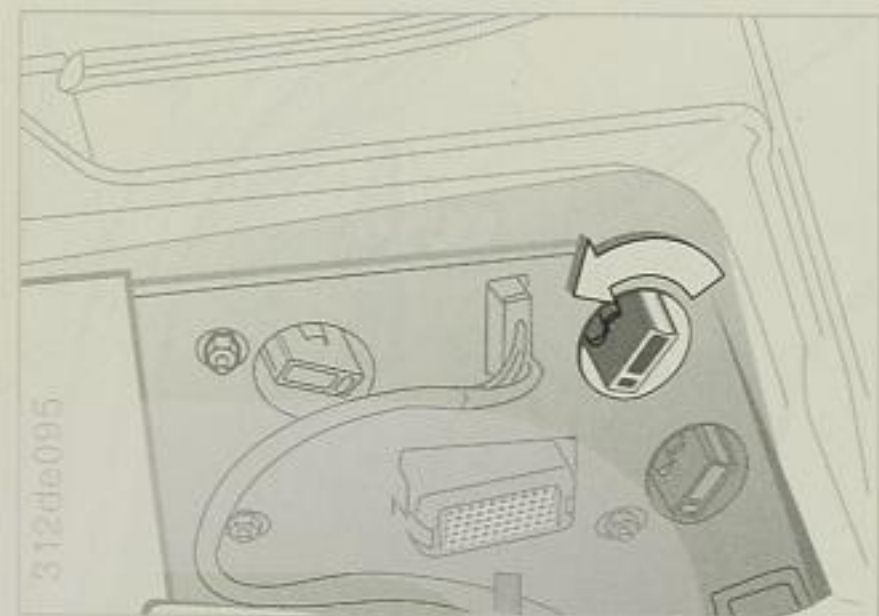

Lights in the luggage compartment lid:

- 1 Raise the trim (quick-release fastener).
- 2 Press the appropriate bulb holder in slightly and turn to the left to remove.
- 3 Remove the bulb in the same way.

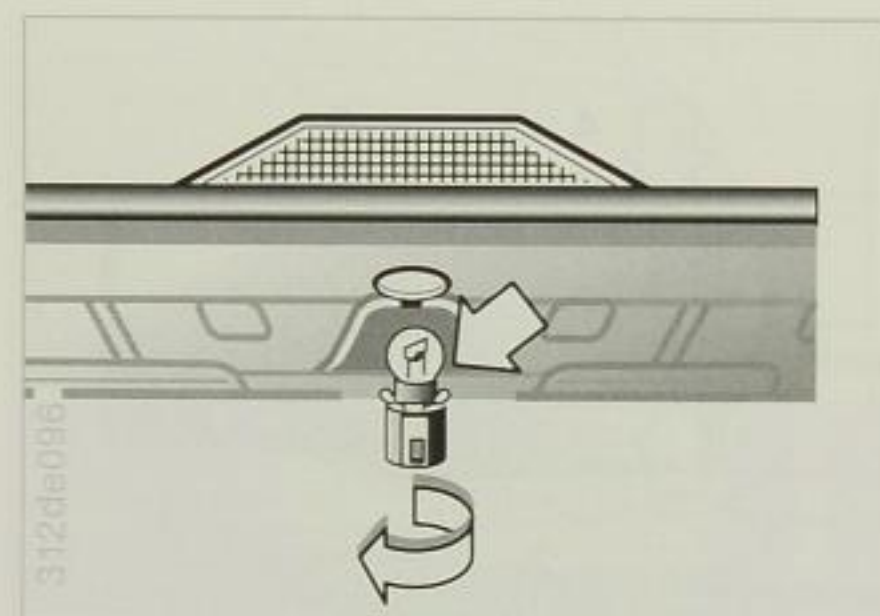

Central brake light

21 Watt bulb

- 1 Open the luggage compartment lid.
- 2 Press the bulb holder slightly, turn to the left and remove.
- 3 Remove the bulb in the same way.

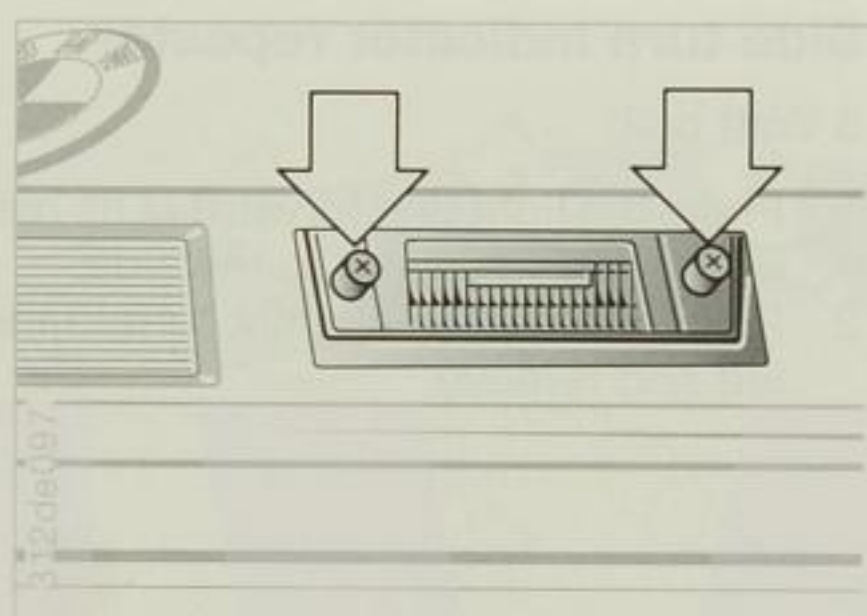

Licence plate lights

5 Watt bulb

- 1 Remove the Phillips-head screws.
- 2 Take off the glass surround with rubber seal.
- 3 Pull the bulb out of the contact tongues.

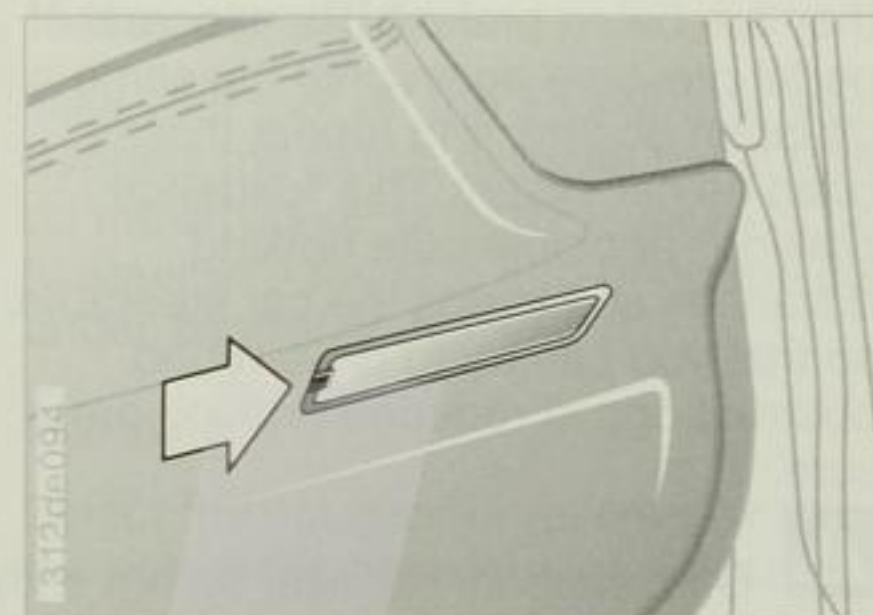

Footwell lights

5 Watt bulb

- 1 Lever the glass carefully out with a screwdriver (arrow).
- 2 Pull the bulb out of the contact tongues.

Interior lights at front

Interior light (10 Watt bulb) with reading lights (10 Watt bulbs)

- 1 Press the light out at the cutout on the left with a screwdriver.
- 2 Interior light: press the plastic lug for the reflector back, swing up the reflector and take out the bulb.
- 3 Reading light: press the bulb in slightly, turn to the left and remove.

Interior lights at rear

10 Watt bulb

- 1 Press the light out at the side recess with a screwdriver.
- 2 Swing up the reflector and take out the bulb.

Luggage compartment lights

10 Watt bulb

Light on underside of rear-window shelf:

- 1 Press it out with a screwdriver at the recess provided.
- 2 Change the bulb.

Lights in luggage compartment lid:

- 1 Pull off the glass.
- 2 Change the bulb.

Engine compartment light

10 Watt bulb

- 1 Press the black lug on the glass towards the centre with a screwdriver and take off the glass.
- 2 Take out the bulb.

Glove box light

5 Watt bulb

- 1 Press the light out of the lower glove box by applying a screwdriver to its outer edge.
- 2 Change the bulb.

Changeable weather in the winter months not only calls for a suitably cautious style of driving but also for certain measures to be taken on the car to ensure that it can be driven safely and without problems throughout the winter.

Coolant

Make sure that the mix ratio of 50:50 (water to long-life antifreeze with corrosion inhibitor) is present. It should remain in the system all the year round, and provides protection down to a temperature of approx. -37°C. Renew the coolant every 3 years.

Locks

Do not use de-icer, as it has a degreasing effect and will impair the functioning of the locks.

Rubber parts

To prevent the seals from freezing together, treat rubber surfaces with a rubber care product or silicone spray.

 Car care products can be obtained from BMW Service. ◀

Snow chains*

BMW snow chains* for all severe winter driving conditions. These can be fitted to various summer or winter tyres, but only in pairs on the drive (rear) wheels. Always observe the tyre manufacturer's safety recommendations. Do not exceed 50km/h (31 mile/h) with snow chains fitted.

Driving on slippery roads

Operate the accelerator pedal sensitively, avoid high engine speeds and shift up to the next higher gear early. On uphill or downhill gradients, select the next lower gear in good time. Maintain a generous distance from the vehicle in front as a safety precaution.

Brakes

Winter road conditions greatly reduce the amount of tyre grip that is available, so that the driver must expect braking distances to be considerably longer than usual in every situation.

ABS prevents the wheels from locking, so that the car remains stable and can always be steered. Should the ABS fail and the road wheels lock, reduce pressure on the brake pedal immediately so that the wheels can still turn although

they are being braked. Then increase pedal pressure again until the same situation occurs, and repeat this as often as necessary. This "cadence braking" principle cuts braking distances and keeps the car steerable, so that you can try to drive round obstructions at reduced braking pressure.

 On a slippery surface, do not shift to a lower gear as a means of braking the car, or the rear wheels may lock and cause the car to skid or the driver to lose control. This applies in particular to cars with ASC+T or DSC if these systems are defective or switched off. ABS cannot counteract this form of wheel locking. ◀

 When applying the brakes hard on slippery roads or if the amount of surface grip varies widely, always declutch as well. ◀

If the car skids

Take your foot off the accelerator and depress the clutch or move the automatic transmission selector lever to N. Try to steer into the skid and bring the car under control in this way.

Parking

Select the 1st gear or reverse, or move the automatic transmission selector lever to P. If parked on a slope, apply the handbrake as well. To prevent the handbrake linings from sticking to the drums as a result of frost or corrosion, dry the drums by applying the handbrake lightly as the car is coming to halt.

 The brake lights do not come on when the handbrake is applied. ◀

When a trailer is towed, the demands on both car and driver are more severe.

A trailer reduces manoeuvrability, the ability to climb hills, acceleration and braking capacity and makes the car handle and corner differently.

For the trailer weight limit and the tow-bar downthrust (nose weight), please refer to the technical data on page 151). The trailer weight limit is also shown in the car's registration papers. Consult any BMW Service station regarding increased trailer weights.

Nose weight

This is the load exerted downwards by the trailer on the ball head of the tow hitch attached to the rear of the car (it can be determined with the aid of bathroom scales or similar).

In Germany a minimum nose weight of 25 kg (55 lb) is laid down by law.

If the trailer weighs more than 1600kg (3527 lb), the nose weight must be at least 50kg (110 lb).

If possible, the nose weight limit should be fully utilized but not exceeded.

The trailer's nose weight is added to the weight of the car, and must not lead to the car's gross weight limit or rear axle load limit being exceeded. The car's payload is reduced by the nose weight if a trailer is being towed, and also by the weight of the trailer tow hitch.

When loading the trailer, make sure that the weight is kept as low as possible and stowed if possible close to the axle.

A low centre of trailer gravity makes the outfit much more stable and safe to drive.

Do not exceed either the trailer's gross weight (axle load) or the specified trailer load limit for the car. The smaller value is the limit which should be adhered to.

The trailer tow hitch* with detachable ball head should be of BMW-approved pattern and, like the trailer turn indicator repeater (which is normally a legal requirement) should be expertly installed by a BMW Service station.

Keep the detachable ball rod greased to make fitting and removing easier.

Note on electrical equipment:

Higher electrical consumption can be expected if a trailer (caravan) is towed. In particular, run high-consumption items for as short a period as possible in order to avoid draining the battery.

The trailer's rear lights, brake lights and rear fog light are protected by plug-in fuses in the trailer electrical module. This is behind the left luggage compartment trim. The fuse for the permanent positive line is in the luggage compartment, next to the left battery in a separate fuse box.

Before acquiring a trailer, it is desirable to obtain from the manufacturer a guaranteed statement of the effective trailer weight and the payload limit.

Both the "comfort" and "sport" suspension settings of your BMW afford optimum safety, ride quality and consistency of handling. They are also perfectly suitable for towing a trailer at up to the standard specified weight, provided that towing is restricted to one vacation period per year, or thereabouts, and the driving style is modified to allow for the more severe operating conditions.

If a trailer tow hitch is retrofitted, it is also a good idea to install the trailer-towing suspension. This compensates for the weight of the tow hitch and also ensures optimum road behaviour when the trailer is not being towed. It is also essential if higher trailer weights are to be towed (possible with certain types of trailers).

BMW does not approve of any other suspension systems offered by the automotive trade for trailer towing purposes.

▶ If a trailer tow hitch is installed, the self-regenerating action of the rear bumper system may not be able to take effect. ◀

The use of a stabilizing device can be recommended, particularly if the trailer is a heavy one. Information can be obtained from a BMW Service station.

The standard outside mirrors may prove inadequate for trailer towing work: the law lays down that the car should be equipped with two outside mirrors with which the rear corners of the trailer can be seen. Mirrors of this kind, including versions with adjustable arms, can be obtained from BMW Service.

In the interests of safety and the avoidance of traffic obstructions, the maximum gradient (applicable at sea level) is limited to 12% or, with a higher trailer load (if authorized), 8%.

As altitude above sea level increases, engine power output tends to drop. You should therefore take particular care when driving through the mountains, since the maximum gradient on which the outfit can be started may be lower than usual. Do not make full use of the car's and trailer's gross weight limits.

Special care must be taken when descending gradients: Always shift down to the next-lower gear at the top of a steep hill (if necessary, right down to 1st gear or by selecting automatic transmission position 1 manually) and descend the hill with great caution.

The maximum speed limit when towing a trailer is 80km/h (50 mile/h) in the Federal Republic of Germany. The trailer load limits have been chosen to ensure ample driving stability up to this speed. If higher speed limits apply in other countries, you are none the less recommended not to drive faster for safety reasons.

If the trailer begins to swing from side to side, the outfit can only be stabilized by braking immediately.

Check car and trailer tyre pressures most carefully. Comply with the trailer manufacturer's tyre pressure instructions.

⚠ Always check that the trailer's rear lights are working before starting a journey. ◀

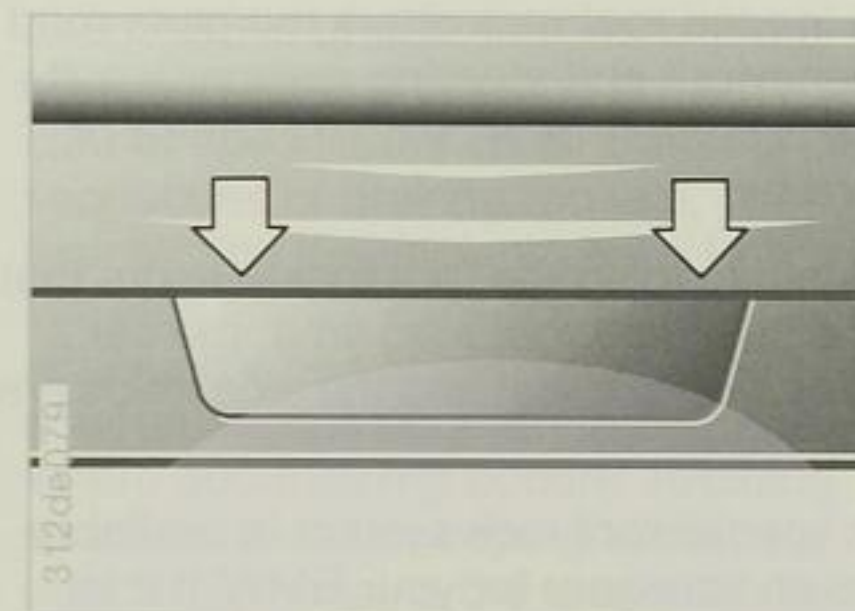

Cover flap for trailer tow hitch

Press the cover down at left and right ends of the upper joint line with a screwdriver (arrows in picture).

Take off the flap and attach the ball head of the tow hitch.

For attaching and removing the ball head, please refer to the accompanying instructions.

To install the cover flap, insert it into the lower guide and press it in at the top.

A loaded roof rack alters the car's road behaviour and steering response quite considerably by moving its centre of gravity.

When loading the roof rack, ensure that the specified roof load limit, the car's gross weight limit and the axle loads are not exceeded.

A special roof rack system is available as an accessory for your BMW. If it is used, please comply with the installation instructions supplied.

The roof load must be uniformly distributed and should not be too large in area. Heavy items of luggage should always be placed at the bottom.

Correct, secure loading of the roof rack will prevent items from shifting or falling off during the journey, and thus endangering following traffic.

Drive smoothly when there is a load on the roof: avoid violent acceleration, braking or cornering.

The roof load increases the car's surface area exposed to the wind, so that fuel consumption will be higher and the loads on the roof structure of the car more severe.

Right/left rule of the road

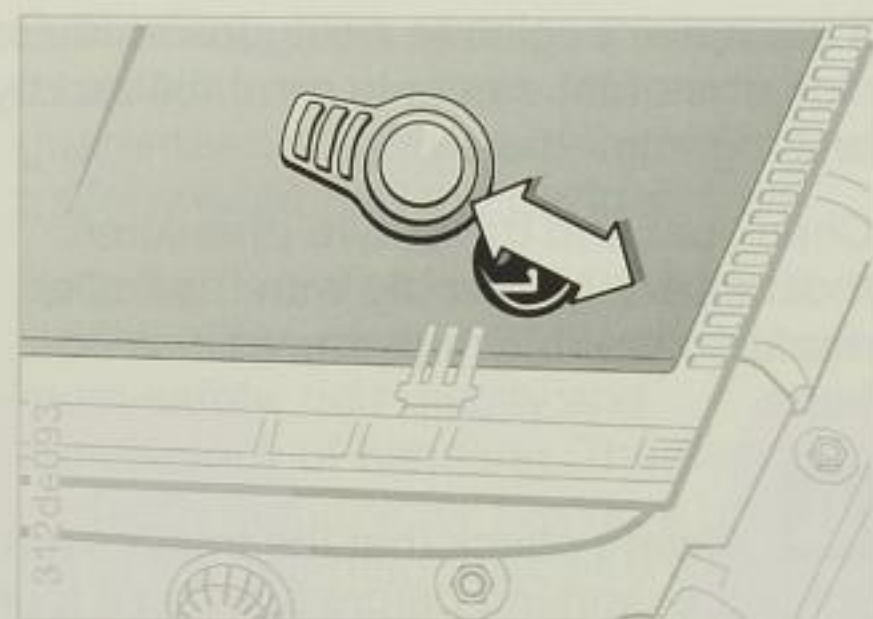

When entering a country in which the traffic drives on the other side of the road:

- 1 Take off the painted upper section of the pop-up headlight: turn the toggle fastener through a quarter of a turn and lift the upper section slightly. Push the upper section forwards and take it off.
- 2 Take out the plug.
- 3 For driving on the left: move the lever to the left. For driving on the right: Move the lever to the right.

 When attaching the painted upper section of the pop-up headlights, make sure that it is correctly seated, particularly at the front mounting points, and that the toggle fastener is properly secured by rotating through a quarter of a turn. ◀

Licensing for use abroad **ABS**

Cars are always supplied to conform with the registration laws of the country in which they are intended for use.

If the owner moves to another country, it is important to check beforehand that import regulations and vehicle licensing laws do not make it too difficult to import the car.

Information can be obtained by telephoning (Germany) 89/3820 if the model, vehicle identification number and date of first registration are quoted.

ABS prevents the wheels from locking when the brakes are applied, and thus increases active safety. With ABS in action, the car achieves the shortest possible braking distances for the prevailing conditions (straight-line braking or cornering, on asphalt, ice, wet roads etc.).

ABS is capable of satisfying two fundamental requirements whenever the brakes are applied:

- ▷ Assured driving stability on varying road surfaces (e.g. asphalt, concrete, mud, wet roads, snow and ice).
- ▷ Assured steerability and manoeuvrability in these conditions.

However, certain important considerations must be borne in mind in connection with these requirements:

Even ABS is unable to eliminate the effects of natural physical laws. It cannot absolve the driver from the consequences of braking too late, maintaining insufficient space from vehicles ahead, exceeding the limits of adhesion when cornering at speed or encountering a poor stretch of road where aquaplaning occurs. Avoiding such situations or coping with them effectively remains the responsibility of the driver.

Although ABS enhances active driving safety, this should not be regarded as an invitation to take correspondingly severe risks.

Driving with ABS

After the engine has been started, the yellow ABS warning light on the instrument panel goes out.

The ABS system itself becomes operational above a road speed of approx. 8km/h (5 mile/h). If the car's speed falls below approx. 3km/h (approx. 2 mile/h), the ABS ceases to operate, so that the wheels could theoretically lock in the very last phase of braking, but in practice this is hardly critical.

The ABS regulating cycle takes place within fractions of a second. The brake pedal pulsates to warn the driver that the ABS is active and therefore that the car is reaching the adhesion limit. A chattering sound, resulting from the brake pressure regulating process, is also heard as a reminder that tyre grip is diminishing (low-grip road surface) and that road speed should be lowered accordingly.

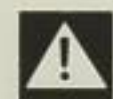

If the road surface consists of loose material on a firm underlayer, for instance stone chippings or powdery snow, the car's braking distance may sometimes actually be longer than if the wheels were to lock.

The same applies if snow chains are fitted. However, the advantages of greater stability and the ability to steer while braking are still available to the driver. To ensure that the ABS system always remains fully operational it must never be modified in any way, and all work on the ABS should be entrusted only to skilled, authorized personnel. ◀

ABS may not operate at full efficiency if different tyre sizes are fitted (for instance winter tyres or the spare wheel). In the latter case, the regular wheel and tyre should be repaired and refitted as soon as possible.

Any malfunction is shown by the yellow ABS warning light on the instrument panel coming on. In this situation the car's brakes continue to work normally, as on a vehicle without ABS, with no restrictions to their performance whatever.

In order to prevent any multiple faults from impairing the brake system, the necessary repair work should be carried out at the next possible opportunity.

Active Rear Axle Kinematics (AHK)*

Unforeseen driving situations often call upon the driver to react swiftly by taking corrective steering action. The vehicle may be felt to respond in a surprising or unpredictable manner as a result. The AHK system modifies or prevents such reactions.

At a speed of approx. 40km/h (approx. 25 mile/h) or above, the AHK is activated with every movement of the steering wheel; it modifies the rear wheel lock angle and repositions the rear wheels ideally to suit the driving situation.

The optimum rear-wheel angle is calculated from the steering wheel's momentary lock angle and the vehicle's road speed; the wheel angles are then adjusted by the electro-hydraulic control circuit. As a result of the vehicle's increased stability, it responds more predictably to steering wheel movements.

However, these improved driving characteristics cannot overcome the basic laws of physics to which a moving vehicle is subject. It remains the responsibility of the driver not to initiate excessive steering-wheel movements or go beyond safe cornering speeds.

Each time the engine is started, the

AHK control unit runs through a self-check sequence. In the event of a system fault, which will be indicated by the telltale light in the instrument cluster and the display "R/AXLE FAILSAFE PROG" in the MID, the lock angle of the rear wheels will no longer be adjusted. The wheels will normally remain in the straight-ahead position, with the result that the vehicle can be driven normally. In exceptional cases, the wheels could remain locked at an angle. If this occurs, the steering wheel will be slightly offset to compensate when the vehicle is travelling in a straight line. Here again, the vehicle can still be driven normally. Note, however, that in this situation the rear wheels will run slightly off-track and the vehicle will occupy marginally more road space across its width as a result.

Minor, temporary faults can be rectified by starting the engine again to initiate the system's self-check. If the telltale light does not go out even after the engine is restarted, contact a BMW Service station to have the system repaired.

Disc brakes offer maximum braking efficiency, responsive control of braking force and the ability to resist severe loads.

If the car is not driven very far, is parked out of use for lengthy periods or is mostly driven very gently, corrosion of the brake discs and contamination of the pads may unfortunately be encouraged, since the minimum pressures between pad and disc which are needed to obtain an automatic cleaning action are seldom reached.

When the brakes are applied, corroded discs tend to judder, and even lengthy brake applications usually fail to eliminate this effect entirely.

 Use only brake pads approved by BMW, or else the car's operating permit will be invalidated. ◀

Driving hints

In damp weather or heavy rain it is advisable to apply the brakes with light pedal pressure every few kilometres. When doing so, make sure that no other road-user is endangered. This will generate sufficient heat to dry out the discs and pads.

It is a well-known fact that the most effective braking is obtained not with locked wheels but when they are still just rotating. ABS maintains this state of affairs automatically. Should the ABS malfunction, the driver should adopt the cadence braking principle if possible (see page 124).

Locked wheels are dangerous because the front wheels cannot then be steered and the rear wheels may slide sideways and cause the car to spin or slide off the road.

To avoid any risk of brake fade when descending long, steep hills, select the gear which calls for a minimum amount of braking (or shift the automatic transmission down to an equivalent speed stage).

Engine braking is more powerful in a lower gear; on a very severe gradient, therefore, you should even shift down as far as first gear or automatic transmission selector position 1 if necessary.

If engine braking alone is insufficient, do not apply the brakes for too long with only slight or moderate force. Instead, it is better to brake the car quite hard (providing that the road behind you is clear) to reduce your speed noticeably, and to repeat this process at brief intervals as necessary. The cooling-down phases between these brake applications should avoid overheating and maintain full braking efficiency.

 Never hold the clutch pedal down, move the gearbox or automatic transmission into neutral or – an even more dangerous practice – switch off the engine while the car is in motion. Engine braking is lost in neutral, and there is no brake servo effect when the engine is stopped. Make sure that the full travel of the brake, clutch and accelerator pedals is never obstructed by the floor carpet, loose mats or any other items. ◀

Information for your safety

The factory-approved radial-ply (braced tread) tyres have been chosen to match your car's performance and to ensure driving safety and the desired standard of ride comfort.

The condition of the tyres and maintenance of the specified tyre pressures not only influence tyre life but also road safety to a very considerable extent.

Incorrect tyre pressures are often a cause of tyre problems. They also have a significant effect on the roadholding of your BMW.

For your own safety you are recommended to check tyre pressures regularly, before starting a long journey and in any case at least once every two weeks.

Inspect tyres frequently for damage, the presence of foreign bodies, unusual wear and sufficient tread depth.

Although the law in many countries calls only for a minimum tread depth of 1.6mm (if indeed any minimum figure is laid down), you are recommended to replace tyres when the tread depth is down to 3mm or else the risk of aquaplaning even on shallow water will be increased.

We recommend fitting new tyres when the treads are 3mm deep. If a tyre remains in use after this, wear indicators 1.6mm from the main rubber surface are exposed as a sign that the legal wear limit has been reached.

When parking the car or driving over loading ramps, workshop hoists etc., make sure that the side walls of the tyres are not damaged by violent contact with obstructions.

 Avoid overloading the car. This can cause the tyres' load capacity limit to be exceeded, so that they overheat and internal damage is caused at a rate which cannot be detected from the outside, possibly leading to sudden pressure loss. ◀

Unusual vibration while the car is being driven could indicate a tyre fault or some other defect on your car. The same applies to any other abnormal road behaviour, such as pulling severely to the right or left. In such cases, reduce speed immediately. Proceed carefully to the nearest BMW Service station or tyre dealer, or have the car towed there so that it can be checked or its tyres inspected.

All forms of tyre damage (which could in the worst case lead to sudden and total loss of pressure) represent a risk of serious or even fatal injury to the car's occupants and to all other road users.

 Never try to drive any further if a tyre goes flat. If air pressure is lost from a tyre, this seriously affects the car's handling and braking, and could cause the driver to lose control. ◀

To maintain the car's good road behaviour, always fit tyres of the same make and tread pattern to all wheels. BMW does not approve of the use of retreaded tyres on this car, since their carcasses may differ in internal construction or have aged sufficiently to cast doubt on their durability and therefore in certain circumstances on their road behaviour and safety.

Interchanging wheels

Tread wear patterns vary between the front and rear wheels, according to the individual conditions in which the car is operated. In the interests of safety and the best possible vehicle behaviour, you are recommended not to adopt the practice of interchanging the wheels.

If you wish to interchange the wheels for reasons of operating cost, remember that the expense incurred in interchanging the wheels also has to be taken into account when assessing whether it is worth trying to extend the tyres' operating life in this way. Consult your BMW Service station.

If you do decide to interchange the wheels, please take the following precautions:

Interchange the wheels on the same side of the car only (though the spare wheel can be included if desired).

Remember that braking efficiency and tyre grip may be adversely affected.

If tyres are interchanged in this way, the process should take place at frequent intervals (max. 5000km/3000 miles).

Spare tyres more than 6 years old should be reserved for genuine emergencies, that is to say if the car's mobility cannot otherwise be maintained. New tyres should be fitted in their place as soon as possible, and they should no longer be brought into regular service when new tyres are fitted.

A tyre's date of manufacture is shown as part of the inscription on the tyre wall: DOT ... 413 means for instance the 41st week of 1993

The correct choice

Wheels and tyres

Use only BMW-approved tyres. In view of the car's maximum speed, certain makes and sizes are compulsory. Details are available from any BMW Service station. In addition, comply with any relevant national regulations.

The correct choice is made easier if the meaning of the tyre markings is understood. Radial-ply tyres are marked as follows:

e.g. 235/50 R 16 95 W

Nominal width in millimetres
Aspect ratio in %
Code letter for radial ply
Rim diameter in inches
Load capacity figure (not on ZR tyres)
Speed code letter (ahead of the R on ZR tyres)

The speed code letter indicates the maximum permissible speed at which the tyre is to be operated.

On summer tyres:

S = up to 180km/h (approx. 112 mile/h)
T = up to 190km/h (approx. 118 mile/h)
H = up to 210km/h (approx. 130 mile/h)
V = up to 240km/h (approx. 149 mile/h)
ZR = over 240km/h (approx. 149 mile/h)
W = up to 270km/h (approx. 167 mile/h)

On winter tyres:

Q M+S = up to 160km/h (approx. 99 mile/h)
T M+S = up to 190km/h (approx. 118 mile/h)
H M+S = up to 210km/h (approx. 130 mile/h)

Marks on light alloy wheels:

9 1/2 J x 18 AH 2

Rim width in inches
Rim shoulder contour code letter
Symbol for well-base rim
Rim diameter in inches
Asymmetric **H**ump on **2** rim shoulders

Prevent dirt from entering the tyre valves by attaching screw-on dust caps. Dirt in the tyre valve can often lead to a gradual loss of air pressure.

If winter tyres (M&S radial-ply) are fitted, the same make and tread pattern should be used on all four wheels (and preferably on the spare wheel as well) in the interests of good directional stability and steering response.

Fit only winter tyres approved by BMW. Any BMW Service station will gladly advise you on the correct winter tyres for the conditions in which your car has to operate.

Always note and comply with the maximum speed limit for your winter tyres.

In Germany a warning notice stating the maximum permitted speed with winter tyres fitted must be displayed in the driver's field of view if the car is capable of a higher speed (please check for similar local legislation).

Suitable labels are available from tyre suppliers or BMW Service stations.

Below a tread depth of 4 mm, winter tyres become noticeably less suitable for winter driving conditions and should therefore be replaced without undue delay for safety reasons.

Keep to the specified tyre pressures and have the wheels rebalanced after every wheel or tyre change.

 Lack of expert knowledge or incorrect handling of tyres can cause damage and lead to accidents. All work on tyres should therefore be carried out only by experts. Your BMW Service station will gladly assist you. ◀

Store wheels and tyres in a cool, dry and preferably dark place when not in use. Protect tyres against contamination from oil, grease and fuel.

Note the tyre and wheel data in the car's official documents. If sizes not approved by the manufacturer are fitted, an entry in the car's documents may be necessary.

BMW fine-link snow chains * may be used with either summer (not on 850CSi) or winter tyres, and must then be fitted to both back wheels. Always observe the tyre manufacturer's safety recommendations when fitting.

Radial-ply tyres (tubeless)	Pressed-steel wheel (rim)	Light alloy wheel	Wheel off-set mm
BMW 840Ci, BMW 850Ci			
225/55 R 16 95 Q/T/H M+S	–	7 1/2 J x 16 H2	15
235/50 R 16 95 W	–	7 1/2 J x 16 H2	15
235/50 R 16 95 Q/T/H M+S	–	7 1/2 J x 16 H2	15
235/45 R 17 93 W	–	8 J x 17 H2	10
235/45 ZR 17	–	8 J x 17 H2	10
235/45 R 17 93 Q/T/H M+S	–	8 J x 17 H2	10
265/40 R 17 96 W*	–	9 J x 17 H2	19
265/40 ZR 17**	–	9 J x 17 H2	19
BMW 850CSi			
235/45 ZR 17	–	8 J x 17 H2	10
235/45 R 17 93 Q/T/H M+S	–	8 J x 17 H2	10
265/40 ZR 17**	–	9 J x 17 H2	19
245/40 ZR 18***	–	8 J x 18 AH2	13
285/35 ZR 18***	–	9 1/2 J x 18 AH2	25

* Only permissible as a mixed set of tyres with 235/45 R 17 93 W at front. Snow chains cannot be fitted.

** Only permissible as a mixed set of tyres with 235/45 ZR 17 at front. Snow chains cannot be fitted.

*** Only permissible as a mixed set of tyres with 245/40 ZR 18 at front. Snow chains cannot be fitted.

Any BMW Service station can provide you with information as to the practical value of an intended modification and whether it is legally permissible and approved by the manufacturer. Enquiries should be accompanied by the vehicle identification number and, if relevant, the engine number.

Light-emitting diodes (LED)

Some of the controls, displays and other interior equipment of your car includes light-emitting diodes behind suitable covers as a light source. These light-emitting diodes are similar in their operating principle to lasers, and are therefore classified by law as "Class 1 light-emitting diodes."

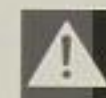

Do not remove the cover or expose the eyes directly to the unfiltered light source for several hours at a time, as this could cause irritation to the iris. ◀

The BMW maintenance system 140
Care of the care 141
Laying the car up out of use 146

Important facts in brief

Controls

Operating hints

Care and maintenance

Technical data

Index

The BMW maintenance system has been planned to ensure that the car always remains safe for the road and reliable without any unnecessary expense for the customer. Regular and correct maintenance also helps to maintain the car's resale value.

Service Indicator

Advanced technologies have been adopted as a means of computing maintenance requirements, which are then shown on the Service Indicator. Whereas conventional maintenance schedules are based entirely on fixed distance intervals, the BMW maintenance system takes the car's operating conditions into account, bearing in mind that "one kilometre is not the same as another": 100000km completed exclusively in the form of short journeys cannot be considered the same as 100000km made up of only long main-road journeys.

The BMW maintenance system based on actual operating conditions consists of an Oil Service and Inspections I and II.

For further information on maintenance points and the scope of maintenance work, please refer to the car's Service Booklet.

Basing service intervals on the actual loads incurred accounts for most regular operating situations. However, if the car is used very little, – that is to say if it covers distinctly fewer than 10000 kilometres (approx. 6,000 miles) a year, – an annual engine oil change should be carried out, since the engine oil ages even if not subjected to mechanical loads.

Service Booklet

It may also be worthwhile having the body checked for stone-impact damage at the same time in order to safeguard against corrosion.

Please make sure that the maintenance work is confirmed in the car's Service Booklet. These entries are evidence that your car has been serviced regularly and correctly and are also the basis of any warranty claims.

Paintwork

The car's paintwork is built up in several layers for protection against corrosion. In addition to cataphoretic dip coating with primer, the body cavities are specially protected with materials that have been subjected to stringent and successful testing for a number of years.

The entire underside of the floor pan is sprayed with a resilient PVC coating and then protected by a complete wax-based underseal coating.

Always remember that regular care of your car will go a long way towards maintaining not only its safe condition but also its resale value.

Environmental influences, which differ from one region to another, can affect your car's paintwork; the nature and frequency of the care you give the car should be governed by these factors.

Road dirt, tar stains, dead insects, bird droppings (powerful alkaline action) and also resin and pollen from trees and bushes all contain substances which could damage the paint surface after a period of time (stains, blistering, caustic burns, peeling off of the top paint layer).

In industrial areas, airborne fly ash, lime, oily soot, acid rain or sulphur dioxide as well as other impurities in the air are bound to attack the paintwork if not cleaned with sufficient regularity, though in most cases only the horizontal panel surfaces are affected.

In coastal regions the high salt content and humidity of the air encourages more rapid corrosion.

In the case of mechanical loads caused by sand, road salt, stone chippings or similar, the paint surface may be broken and corrosion may then be able to develop under the paint and spread out from the damaged areas.

Awareness of these negative environmental effects on the paintwork has stimulated motor vehicle and paint manufacturers to increase the durability and strength of their paints wherever possible.

BMW Service stations supply factory-tested Original BMW car care products for all general work of this kind which you intend to carry out yourself.

Care of paintwork

As a precaution against the long-term effects of substances which attack the paintwork in areas where air pollution is high (industrial areas, railways) or where natural pollutants are encountered (tree sap or resin, pollen, bird droppings), you are recommended to wash the car once a week. In particularly severe cases, the car's body should be washed immediately.

Spilled or overflowing fuel, oil, grease and brake fluid must be removed immediately or else they will attack or discolour the paint; the same applies to bird droppings, which will cause local damage to the paint.

Car wash

A new BMW can be put through an automatic car wash or washed by hand from the beginning on.

However, do not wash the car in the sun, immediately after it has stood in the sun or when the engine compartment lid is still warm in order to avoid blotches on the paintwork.

If an automatic car wash is used, make sure that

- ▷ add-on body elements such as spoilers cannot be damaged. If in doubt, consult the car wash operator first.
- ▷ The brush pressure must be as low as possible and the car wash should operate with ample rinsing water.

Before washing the car, it is best to soak and wash off dead insects.



If a steam jet or high-pressure washer is used, make sure that it is held sufficiently far away from the car's panel surfaces. If it is held too near or if the pressure is excessive, the bodywork could either become damaged immediately or eventual damage prompted. In addition, water could penetrate various components on the car and cause long-term damage or failure. ◀

Body areas not always reached effectively by the car wash brushes, such as door sills, door seams and panel gaps, should be cleaned by hand.

During the winter months, in particular, wash the car more frequently. Severe dirt and road salt are difficult to remove and tend to damage the paintwork if not removed promptly.



After the car has been washed, the brakes may be damp and therefore less efficient. Dry the brake discs by applying them briefly as soon as the car is driven. ◀

After washing, residual dirt will be clearly visible. It should be removed without delay, using cleaning-grade benzene or white spirit on a clean cloth or wadding. Clean off tar stains with a tar remover.

Finally, apply a paint protection product to the treated areas.

Paint protection

For paint protection, use only products containing carnauba or synthetic waxes.

A sure sign that the paintwork needs protective treatment is when water no longer forms large droplets and rolls off the surface. Depending on how and where the car is used, this can be the case after only 3 to 4 months.

Remove care product residues and silicone from the windscreen with glass cleaner.



Cleaning and car care products can be obtained from BMW Service. ◀

Rectifying paint damage

Minor paint damage can be touched in with a BMW paint spray can or a BMW paint pencil or repaired with BMW paint film.

Your car's paint finish is stated on a label close to its type plate, and also on the first page of the Service Booklet.

Scratches and damage caused by flying stones must be repaired immediately to prevent rust from forming.

If any areas of the body have already started to rust as a result of paint damage, clean them with a wire brush and apply a rust inhibitor or converter (protect the eyes and skin.) Allow to act for several minutes, then rinse off with water and allow the treated area to dry thoroughly. Apply primer and allow this to dry thoroughly, then apply the top coat. After a few days, polish the repainted areas and apply paint protection.

More widespread paint damage should be entrusted to a BMW service station, which can repair it expertly in accordance with the manufacturer's specifications and using Original BMW paint materials.

Care of special parts

Light alloy wheels should be treated with wheel cleaner, but do not use products which are of an aggressive nature, contain acid or abrasives or are strongly alkaline. Steam jets used to clean the wheels should not reach a temperature of more than 60°C. (In all cases, comply with the manufacturer's instructions.)

The insides of the windows and the mirror glasses can be cleaned with a glass cleaner which leaves no smears. Never clean mirror glasses with products containing quartz or similar abrasive polishing pastes.

Plastic parts, imitation leather upholstery or trim, roof linings, light glasses and parts sprayed with matt black paint must be cleaned with water, to which a car shampoo can be added if required. Do not allow the roof lining to become wet right through. If necessary, treat plastic parts with a plastic cleaner. Never use solvents such as nitro thinners, cold cleansers, fuel or similar.

Apart from water, treat rubber parts only with rubber care products or silicone spray.

Clean the wiper blades with soapy water. They should be renewed twice a year (before and after the winter season).

Seat belts should only be cleaned with mild soap suds (without removing them from the car). Do not dry-clean or use chemical products, or the fabric may be weakened.

Never allow automatic seat belts to retract unless they are dry. Dirt on the seat belts can interfere with the action of the reel and represent a safety hazard.



Your BMW Service station can supply suitable car care products. ◀

Floor carpets and mats can be cleaned with a car interior cleaner* if very dirty. The floor mats can be taken out of the car to enable the interior to be cleaned more thoroughly.

Care of upholstery

The pressure areas which occur when cloth seats are in regular daily use can be restored by brushing against the pile direction with a slightly moistened brush.

The tendency of the pile to lie in a particular direction on velour upholstery is not a quality defect, and, just as on home textiles or clothing, cannot be avoided.

Remove fluff from cloth upholstery and rubbed-in threads or scraps of cloth or suede with a suitable fluff roller or burr brush. A cleaning glove is available to remove particularly obstinate fluff. Stains and fairly large areas of dirt should be cleaned off without delay using lukewarm water and an interior-cleaner, stain remover or cleaning-grade benzene. Brush the fabric afterwards to restore its appearance.

Cover the seats if exposed to hot summer sun for lengthy periods, so that the upholstery does not fade.

The build-up of a static electrical charge on the seats, particularly if atmospheric humidity is low, can give the occupants an unpleasant electric shock if they touch metal parts of the car after leaving it. Although this is not dangerous in any way, it can be avoided by touching a bare or polished metal part of the car while getting out.

If necessary, anti-static products can be used to eliminate this effect to a large extent.

 Your BMW Service station can supply suitable car care products. ◀

Care of leather

The upholstery leather used by BMW* is a natural product of the highest quality processed by the very latest methods and will retain its fine appearance for many years if correctly treated.

Since leather is an absolutely natural product, its characteristics and certain restrictions on its use and special care precautions must be noted.

Regular cleaning and care are needed, since dust and dirt, for instance from the roads, collect in pores and creases, cause severe abrasion and can lead to the leather surface becoming prematurely brittle.

If exposed to strong sunlight when the car is parked for a lengthy period, leather-upholstered seats should be covered or the windows blanked off to prevent fading.

To clean, slightly moisten a cotton or woollen cloth with water and rub the leather surface gently without allowing moisture to collect in the seams. Dry and rub down with a clean, soft cloth.

Leather that has become very dirty can be cleaned with a mild detergent containing no brighteners (2 tablespoons in

1 litre of water). Dab grease or oil stains carefully with cleaning-grade benzene, without rubbing them hard.

After cleaning, leather surfaces should be treated with a suitable leather care product* to protect them and prevent the build up of a static electrical charge. Shake well and apply a thin coating with a soft cloth. Allow to dry and rub with a clean, soft cloth.

In normal conditions, repeat this treatment every six months.

 Your BMW Service station can supply suitable car care products. ◀



Keep cleaning products out of the reach of children. Many products are toxic or flammable, and therefore hazardous in use. Before using any such product, study and comply with the instructions supplied with it and note any warnings or precautions stated on the pack.

When cleaning the car's interior, always open a door or window. Never use products or solvents not specified for cleaning the car. ◀

Ask your BMW Service station for advice on the work needed if you plan to lay the car up out of use for more than three months.

Important facts in brief

- Engine data 148
- Fuel consumption, carbon dioxide/CO₂ emissions 149
- Dimensions 150
- Weights 151
- Performance 152
- Filling capacities 153
- Electrical system 154
- V-belts 154

Controls

Operating hints

Care and maintenance

Technical data

Index

Tech. data

Keyword

		BMW 840Ci	BMW 850Ci	BMW850CSi
Displacement	cm ³	3982	5379	5576
Number of cylinders		8	12	12
Max. power output	kW	210	240	280
	bhp	286	326	380
- at engine speed	1/min	5800	5000	5300
Max. torque	Nm	400	490	550
at engine speed	1/min	4500	3900	4000
Compression ratio	e	10.0	10.0	9.8
Bore/stroke	mm	80/89	79/85	80/86
Mixture preparation		Digital Motor Electronics		

		BMW 840Ci	BMW 850Ci	BMW 850CSi
		6-speed gearbox	Automatic transmission	Automatic transmission
				6-speed gearbox
Fuel consumption acc. to DIN 70 030/1 ECE				
at 90 km/h	litres/100 km (Imp. mile/gal)	7.9 (35.8)	7.7 (36.7)	8.5 (33.3)
at 120 km/h	litres/100 km (Imp. mile/gal)	9.6 (29.5)	9.3 (30.4)	10.2 (27.7)
Urban cycle	litres/100 km (Imp. mile/gal)	17.7 (16.0)	17.2 (16.5)	19.8 (14.3)
Average	litres/100 km (Imp. mile/gal)	11.7 (24.2)	11.4 (24.8)	12.8 (22.1)
Urban roads	litres/100 km (Imp. mile/gal)			
Country roads	litres/100 km (Imp. mile/gal)			
Total	litres/100 km (Imp. mile/gal)			
CO ₂ emissions	gram/km			

Values not available on closing for print

Fuel consumption is determined according to a standard test method (93/116/EC). It is not the same as the average fuel consumption, which depends on many different factors such as driving style, load, road condition, traffic density, weather, tyre pressures etc.

Engine power output and performance are measured in accordance with the conditions laid down by the valid German industrial standards, and with the car to standard equipment specification. This standard specifies the permitted tolerances.

Optional extras often have a considerable influence on performance and fuel consumption, since they cause the car's weight or its drag coefficient to vary (roof rack, wider tyres, additional mirrors etc.).

		BMW 840Ci	BMW 850Ci	BMW 850CSi
Length	mm	4780	4780	4780
Width	mm	(4023)1855	(4023)1855	(4023)1855
Height (unladen)	mm	1340	1340	1330
Wheelbase	mm	2684	2684	2684
Front track	mm	1554	1554	1564
Rear track	mm	1562	1562	1554
Turning circle(wheels)ø	m (ft)	11.5	11.5	11.5

		BMW 840Ci	BMW 850Ci	BMW 850CSi
Unladen weight (ready for road, tank full, without optional extras)				
with 6-speed gearbox	kg (lb)	1855 (4081)	–	1975 (4345)
with automatic transmission	kg (lb)	1905 (4191)	1995 (4308)	–
Gross weight limit				
with 6-speed gearbox	kg (lb)	2200 (4840)	–	2340 (5148)
with automatic transmission	kg (lb)	2250 (4950)	2300 (5060)	–
Front axle load limit	kg (lb)	1115 (2435)	1140 (2508)	1150 (2530)
Rear axle load limit	kg (lb)	1195 (2629)	1195 (2629)	1230 (2702)
Trailer loads (according to manufacturer's directives and as legally authorized in Germany) Your BMW Service station can supply information on permissible increases. Note and comply with different values in certain countries.				
Unbraked	kg (lb)	750 (1650)	750 (1650)	–
Braked, max. gradient 12 %	kg (lb)	1675 (3685)	1675 (3685)	–
Braked, max. gradient 8 %	kg (lb)	1875 (4125)	1875 (4125)	–
Please consult BMW Service if you wish to tow a heavier trailer.				
Trailer nose weight	kg (lb)	75 (165)	75 (165)	–
Roof load	kg (lb)	75 (165)	75 (165)	75 (165)
Neither axle load nor gross weight limits must be exceeded.				
Luggage capacity acc. to VDA test	l (cub.feet)	320 (704)	320 (704)	320 (704)

		BMW 840Ci	BMW 850Ci	BMW 850CSi
Top speed (governed)	km/h	250 (155)	–	250 (155)
With 6-speed gearbox	(mile/h)	governed	–	governed
With automatic transmission	km/h	250 (155)	250 (155)	–
	(mile/h)	governed	governed	–
Acceleration	km/h	s	s	s
	(mile/h)			
from	0 – 50	2.6 (3.1)	(2.6)	2.5
	0 – 80	5.0 (5.4)	(4.6)	4.6
	0 – 100	6.9 (7.4)	(6.3)	6.0
	0 – 120	9.5 (9.8)	(8.5)	8.2
80 - 120 km/h in 4th gear		6.9/–	–	5.9
Standing-start kilometre	in	26.9 (27.4)	(26.1)	25.5

Values in (): automatic transmission

	Litres (Imp. gal.)	Note
Fuel tank	approx. 90 (19.8)	Fuel grade: page 23
Windscreen washer	approx. 2.5 (.6)	For further details, see page 103
Headlight cleaning system	approx. 9.0 (2.0) – BMW 840Ci, 850Ci	
Models with AHK (filler located in luggage compartment)	approx. 4.5 (1.0)	
Intensive cleaning system	approx. 1.0 (.2)	
Cooling system, incl. heater circuit	12.0 (2.6) – BMW 840Ci 13.0 (2.9) – BMW 850Ci, 850 CSi	For further details, see page 102
Engine oil with filter renewal	7.5 (1.6) – BMW 840Ci 8.0 (1.8) – BMW 850Ci 8.25 (1.8) – BMW 850CSi	Brand-name HD oil for spark-ignition engines Oil grades: page 99
Manual gearbox	1.75 (.4) – BMW 840Ci 2.3 (.5) – BMW 850CSi	ATF (BMW service stations are familiar with the correct grades)
Automatic transmission	– – BMW 850CSi	ATF (BMW service stations are familiar with the correct grades) Permanently filled without oil changes. Apart from inspection work, there are no plans for oil level checks to avoid incorrect fluid levels. Contact a BMW Service in exceptional cases
Rear axle drive	1.9 (.4) – BMW 840Ci, 850Ci 2.7 (.6) – BMW 850CSi	Brand-name hypoid oil (See your BMW Service station for information on oils)

Batteries in luggage compartment

2 x 12 Volt, 65 Ah

Spark plugs

BMW 840Ci

Double-earth electrode:
Bosch F7 LDCR or NGK BKR 6 EK

BMW 850Ci

Double-earth electrode:
F9 LCR

BMW 850CSi

Double-earth electrode:
Bosch F8 LCR2

V-belts

Alternator, power steering

BMW 850Ci

Ribbed 7 K x 1035

BMW 850CSi

Ribbed 6 K x 1080

Water pump and air conditioning

BMW 850Ci

Ribbed 5 K x 1165

BMW 850CSi

Ribbed 6 K x 1195

Water pump, air conditioning and second alternator

BMW 850Ci, 850CSi

Ribbed 5 K x 1190

Second alternator

BMW 850Ci, 850CSi

Ribbed 3 K x 590

Water pump, alternator and power steering

BMW 840Ci

Ribbed 7 K x 1605

Air conditioning compressor

BMW 840Ci

Ribbed 7 K x 980

From A to Z 156

Important facts in brief

Controls

Operating hints

Care and maintenance

Technical data

Index

ABS (antilock brake system) 17
 Active Rear Axle Kinematics (AHK) 17, 131
 Adaptive program (AGS) 72
 Adaptive Transmission Control (AGS) 70
 Adding engine oil 98
 AGS (adaptive program) 72
 AHK (Active Rear Axle Kinematics) 17, 131
 Air conditioning 81
 Airbag restraint system 17, 44
 Airbag safety instructions 45
 Alarm system 34
 Approved wheels and tyres 137
 ASC (Automatic Stability Control) 16
 ASC+T (Automatic Stability Control plus Traction) 74
 Ashtray 86
 Aspherical wide-angle mirror 40
 Automatic air conditioning 78
 Automatic anti-glare inside mirror 41
 Automatic interior light 47
 Automatic Stability Control (ASC) 16
 Automatic Stability Control plus Traction (ASC+T) 74
 Automatic transmission 68
 Automatic transmission with STEPTRONIC 70
 Average fuel consumption 58
 Average speed 58

Batteries 32, 106
 Battery charge 16
 Brake fluid 101
 Brake hydraulics 17
 Brakes 22, 105, 124
 Bulb-changing 119
 Car phone 92
 Car radio operation 91
 Car wash 142
 Carbon dioxide/CO2 emissions 149
 Care of special parts 143
 Care of the car 141
 Catalytic converter 90
 Central locking 28
 Changing a wheel 113
 Charging the battery 107
 Check Control 64
 Checking engine oil level 98
 Child restraint systems 43
 Cigarette lighter 86
 Clock 54
 CO2 emissions 149
 Convenient opening/closure 50
 Convenient operation of sunroof 51
 Convenient window operation 50
 Coolant 102
 Coolant thermometer 19
 Daytime lights 45
 Daytime driving lights 120
 Digital clock 54

Dimensions 150
 Dipped headlights 46
 Disc brakes 132
 Distance from destination 58
 Distance recorder 18
 Doors 27
 Driver's door lock hearing 29
 Driving 132
 Driving area 12
 Driving hints 90
 DSC (Dynamic Stability Control) 16, 76
 Dynamic Stability Control (DSC) 16, 76
 EDC (Electronic Damping Control) 74
 Electric mirror heating 40
 Electric outside mirrors 40
 Electric sunblind 85
 Electric windows 50
 Electrical system 154
 Electronic Damping Control (EDC) 74
 Electronic engine output control (EML) 16
 Electronic immobilizer 26
 EML (Electronic engine output control) 16
 EML (programmable electronic engine output control) 67
 Engine compartment 94, 95, 96
 Engine compartment lid 92
 Engine compartment light 92

Engine data 148
 Engine oil 98
 Engine oil level check 98
 Fasten seat belt 16
 Fillin capacities 153
 Fire extinguisher 109
 First aid box 110
 Flashers 16
 Flashing turn indicators 120
 Fog light switches 46
 Fog lights 16, 46, 119
 Folding rear seat backs 87
 Fuel consumption 149
 Fuel filler flap 116
 Fuel gauge 19
 Fuel grade 23
 Fuses 108
 Glove box 85
 Handbrake 17, 66
 Hazard warning flashers 47
 Head restraints 36
 Headlight beam throw adjustment 48
 Headlight cleaning system 49
 Headlight flasher 120
 Headlights 117
 Heated rear window 83
 Heated windscreen washer jets 49
 High beam headlight 120
 High beam headlights 120
 High-beam headlights 16

Hydraulics 100
 Ignition/starter switch 20
 Immobilizer 26, 62
 Independent heater 60
 Independent ventilation control 60
 Initializing remote control 33
 Inside mirror 41
 Instrument lighting 46
 Instrument panel 14
 Intensive cleaning system 103
 Interchanging wheels 134
 Interior light 31
 Interior lights 47
 Jack 113
 Key with radio remote control 30
 Keys 26
 Laying up out of use 146
 Leather care 145
 LED (light-emitting diodes) 138
 Light-emitting diodes (LED) 138
 Low beam headlights 119
 Luggage compartment 29, 117
 Lumbar support 37
 Maintenance system 140
 Manual gearbox 67
 Master keys 32
 MID (Multi-Information Display) 52
 Mirrors 40
 Multi-Information Display (MID) 52

Non-automatic anti-glare inside mirror 41
 Oil pressure engine 16
 On-board computer 56
 Outside temperature display 57
 Parking lights 46, 120
 Passenger's side mirror tilt-down 40
 Performance 152
 Pop-up headlights 117, 119
 Position memory for seats, mirrors and steering wheel 42
 Power steering 105
 Programmable electronic engine output control (EML) 67
 Radio remote control 30
 Rear fog light 16
 Rear fog lights 46
 Recirculated air mode 82
 Refuelling 23
 Reifenprofil 133
 Remote control of on-board computer 63
 Retreaded tyres 134
 Reverse 67
 Reversing lights 67
 Revolution counter 18
 Roof rack 128
 Rule of the road 128
 Running in 22

Seat adjustment 36
 Seat back release 38
 Seat belts 42
 Seat heating 37
 Seats 36
 Service Interval indicator 53
 Side lights 45, 120
 Ski bag 87
 Sliding/tilt sunroof 117
 Spare wheel 113
 Speed limit (LIMIT) 59
 Starting the engine 21
 Starting with a flat battery 112
 Steering column adjustment 38, 39
 Steering hydraulics 17
 Steering lock 20
 Steering wheel adjustment 39
 Steering wheel position memory 42
 Stopping the engine 21
 Stopwatch 60
 Sun visors 41
 Sunblind 85
 Sunroof 51, 117
 Technical modifications 138
 Telltale 16
 Telltale lights 16
 Thieftproof wheel studs 116
 Toolkit 109
 Towing away 111
 Tow-starting 111
 Tow-starting and towing away 110
 Trailer nose weight 125

Trailer towing 125
 Trailer turn indicators 17
 Transmission shift programs 69
 Trip distance recorder 18
 Turn indicator repeater 121
 Turn indicators 16, 46
 Type plate 93
 Tyre pressures 24, 133
 Tyre treads 133
 Tyres 22, 133
 Upholstery care 144
 V-belts 154
 Vehicle identification number 93
 Warning lights 16
 Warning triangle 109
 Washer and cleaning system fluid 103
 Washer jets 104
 Weights 151
 Wheel stud wrench 115
 Wheels 135
 Wheels and tyres 135
 Windscreen washer 48, 103
 Windscreen washer jets 104
 Winter tyres 136
 Wiper blade renewal 118
 Wipers 48

WAWAG